

# End-of-semester info

- **Final exam info:**
  - December 14 (8 am) & 18 (7 pm)
  - Approximately 49 questions
  - Cumulative (all material from semester **covered evenly**)
- **Lectures next week:**
  - Monday: Lect. 28 “Relativity”
  - Wednesday: in-class review
- **CHECK GRADEBOOK!**
- **Online ICES evaluation!**

# Physics 102: Lecture 28

## Special Relativity



**How mechanics changes at high speeds**

# Postulates of Relativity

- Laws of physics are the same in every inertial frame

# Inertial Reference Frame

- Frame which is in uniform motion (constant velocity)
  - No Accelerating
  - No Rotating
- Technically Earth is not inertial, but it's close enough.

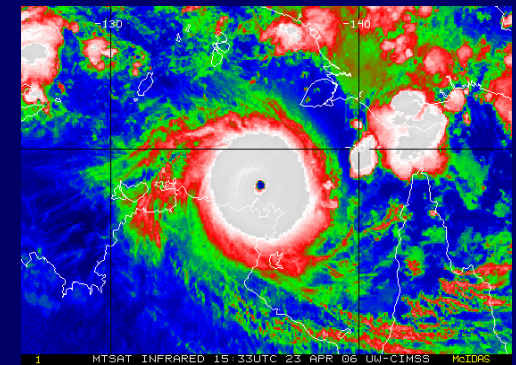
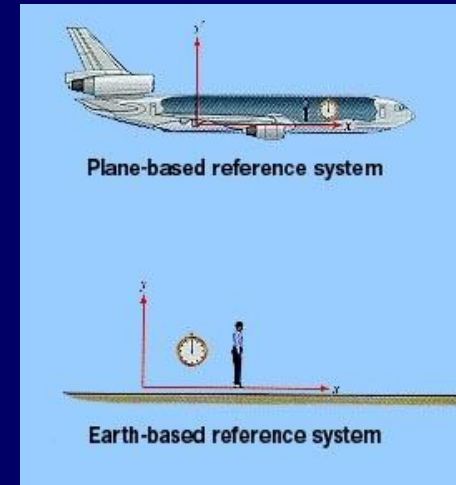

# Postulates of Relativity

- **Laws of physics are the same in every inertial frame**
  - the same laws of physics can be used in any inertial reference frame and the results will be consistent for that frame.
- **Speed of light in vacuum is  $c$  for everyone**
  - Measure  $c=3 \times 10^8$  m/s if you are on train going east or on train going west, **even if light source isn't on the train.**

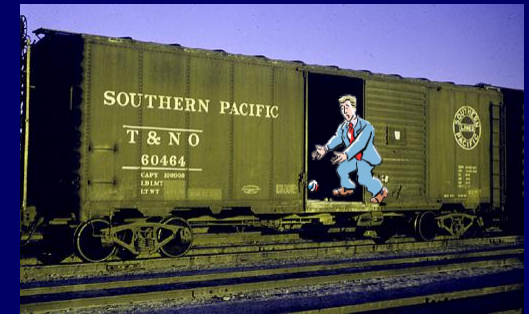

*Weird!*



# Example

## Relative Velocity (Ball)

- Jeff Samardzija throws baseball @90 mph.  
How fast do I think it goes when I am:

– Standing still?

90 mph

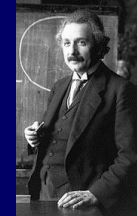

– Running 15 mph towards?

$90+15=105$  mph

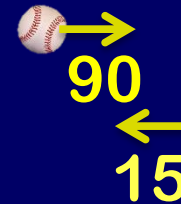

– Running 15 mph away?

$90-15=75$  mph



(Review 101 for help with Relative Velocities)

# Example

## Relative Velocity (Light)



- Now he throws a photon ( $c=3 \times 10^8$  m/s). How fast do I think it goes when I am:

– Standing still

$3 \times 10^8$  m/s

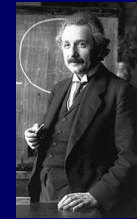
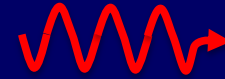

– Running  $1.5 \times 10^8$  m/s towards

$3 \times 10^8$  m/s

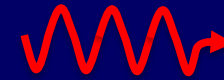

←  
15



– Running  $1.5 \times 10^8$  m/s away

$3 \times 10^8$  m/s

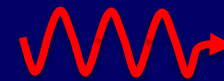

→  
15



### Checkpoint 1

### Strange but True!

# Consequences: 1. Time Dilation

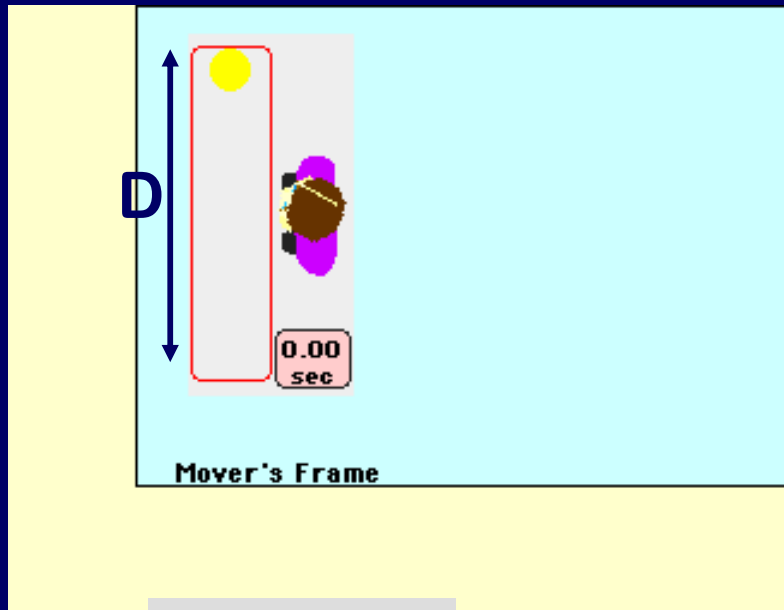

$$c\Delta t_0 = 2D$$

$$\Delta t_0 = \frac{2D}{c}$$

$t_0$  is called the “proper time”. Here it is the time between two events that occur at the same place, in the rest frame.

# Time Dilation

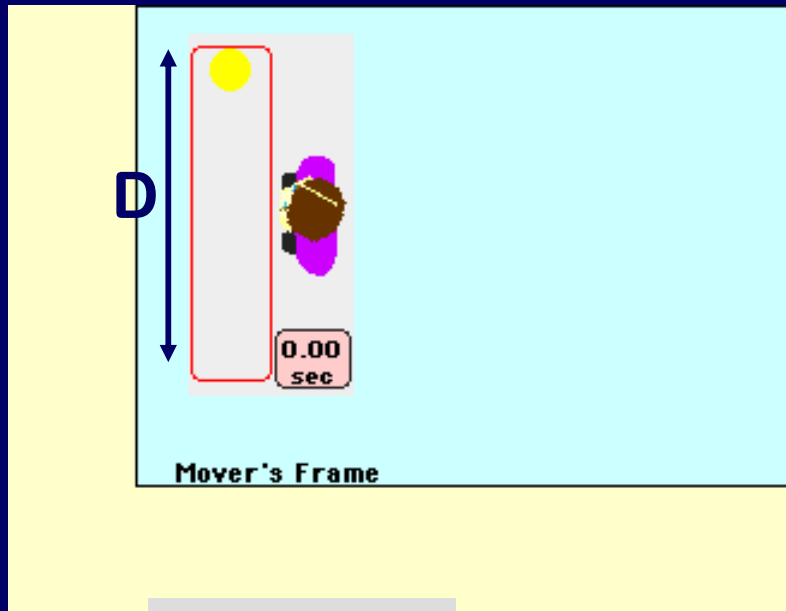

$$c\Delta t_0 = 2D$$

$$\Delta t_0 = \frac{2D}{c}$$

$t_0$  is proper time  
Because it is rest  
frame of event

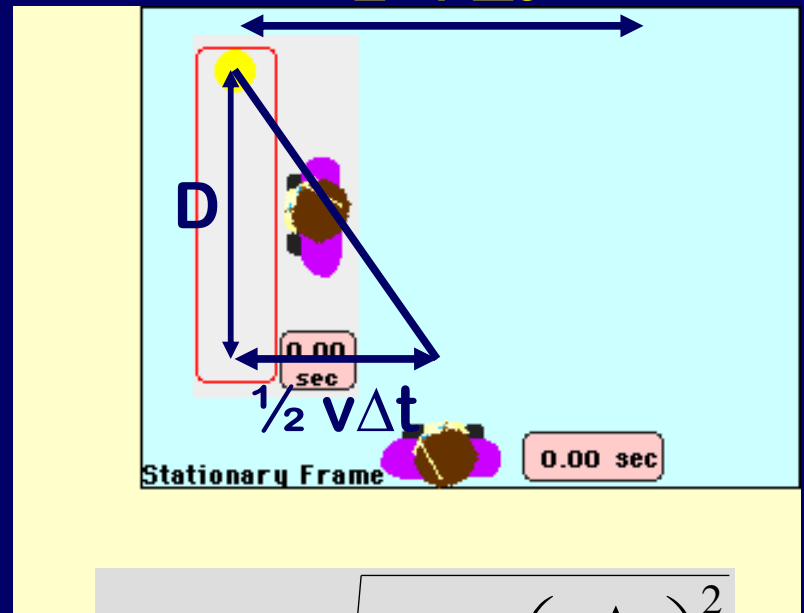

$$c\Delta t = 2\sqrt{D^2 + \left(\frac{v\Delta t}{2}\right)^2}$$

$$\Delta t = \frac{2D}{c} \frac{1}{\sqrt{1 - \frac{v^2}{c^2}}} > \Delta t_0$$

$$\Delta t = \frac{\Delta t_0}{\sqrt{1 - \frac{v^2}{c^2}}}$$

Importantly, when deriving time dilation the two events,

- 1) photon leaving right side of train and
  - 2) photon arriving back at right side of train,
- occur **at same point on the train**.

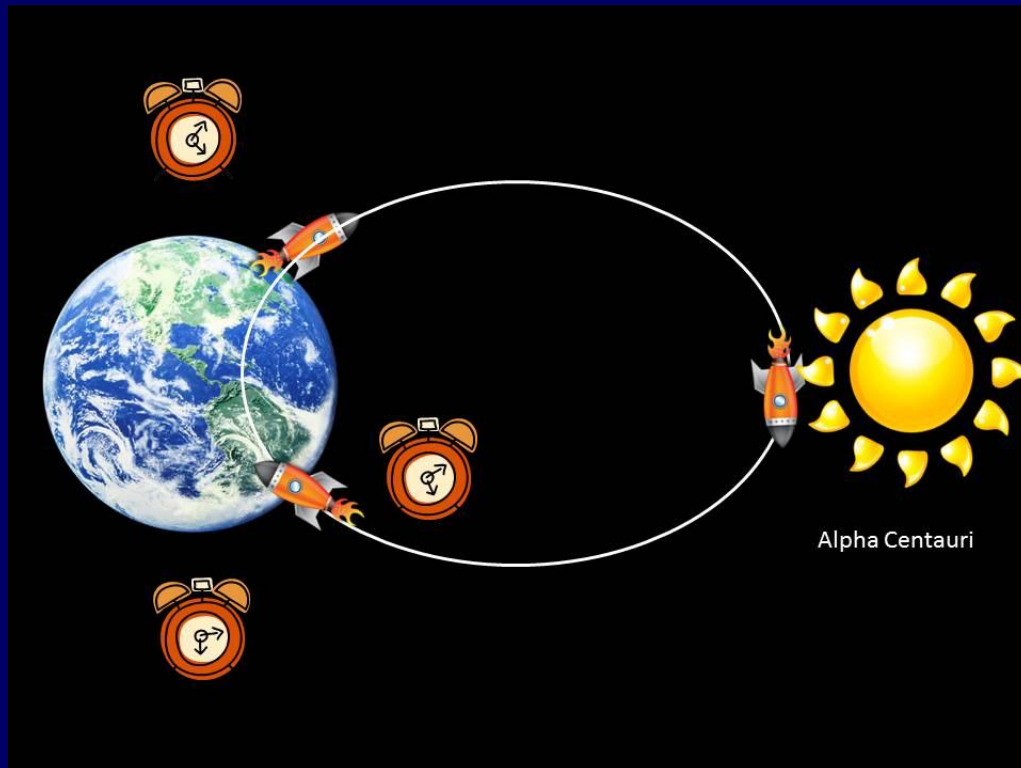

“Moving  
clocks  
run  
slowly”

Checkpoint 2:  
“twin paradox”

# Example



## Time Dilation

A  $\pi^+$  (pion) is an unstable elementary particle. It may decay into other particles in 10 nanoseconds (when at rest)

Suppose a  $\pi^+$  is created at Fermilab with a velocity  $v=0.99c$ . How long will it live before it decays?

$$\Delta t = \frac{\Delta t_0}{\sqrt{1 - \frac{v^2}{c^2}}} = \frac{10 \text{ ns}}{\sqrt{1 - \frac{(0.99c)^2}{c^2}}} = \frac{10 \text{ ns}}{\sqrt{1 - (0.99)^2}} = 71 \text{ ns}$$

- If you are moving with the pion, it lives 10 ns
- In lab frame where it has  $v=0.99c$ , it lives 7.1 times longer
- Both are right!
- This is not just “theory.” It has been verified experimentally (many times!)

# Example

# Time Dilation



$v/c$	$\gamma$
0.1	1.005
0.2	1.021
0.5	1.155
0.9	2.294
0.99	7.089
0.999	22.366
0.9999	70.712
0.99999	223.607
0.999999	707.107
0.9999999	2236.068

$$\gamma = \frac{1}{\sqrt{1 - \frac{v^2}{c^2}}}$$
$$\Delta t = \gamma \Delta t_0$$

# Consequences: 2. Length contraction

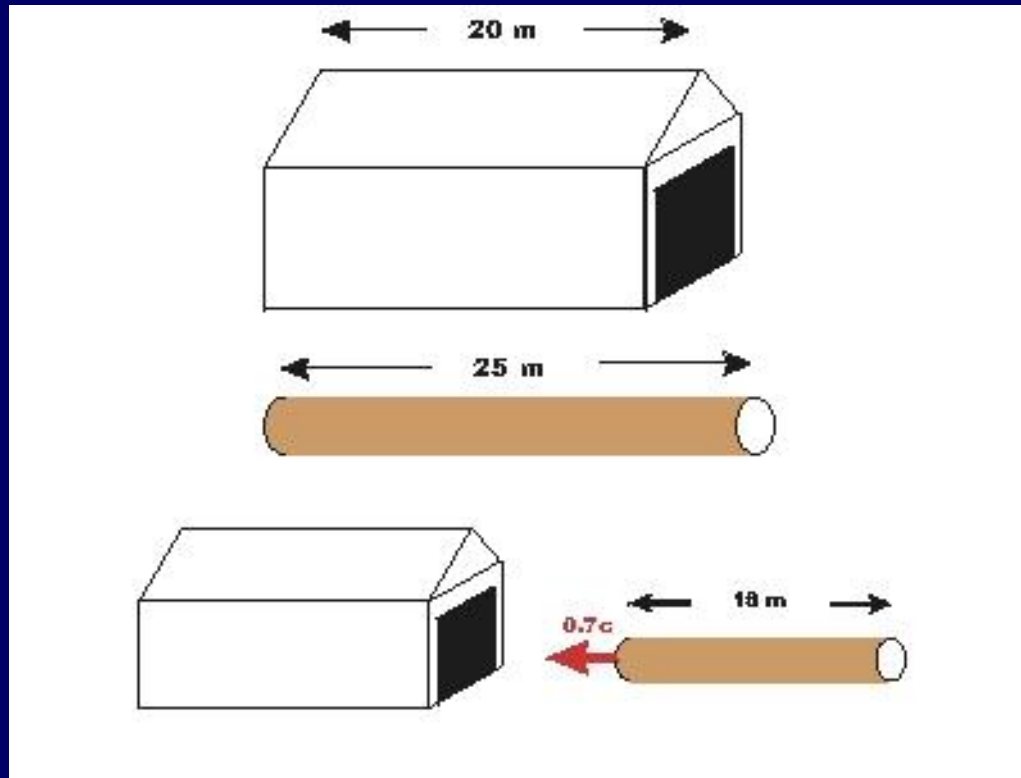

## On board a Train



send photon to end  
of boxcar & back:

$$\Delta t_0 = 2 \Delta x_0 / c$$

$$\Delta x_0 = c \Delta t_0 / 2$$

$\Delta t_0$  = time for light to travel to  
front and back of train for the  
observer on the train.

$\Delta x_0$  = length of train according  
to the observer on the train.

## Train traveling to right with speed $v$

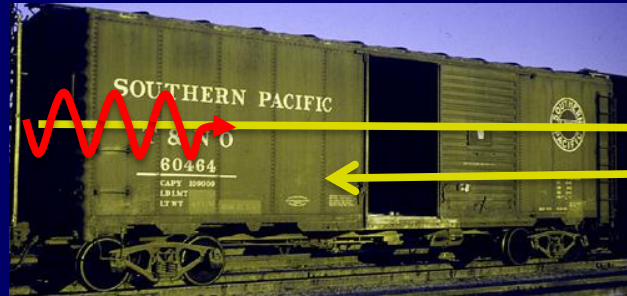

$$\Delta x$$

the observer on the ground sees :

$$\Delta t_{\text{forward}} = (\Delta x + v \Delta t_{\text{forward}}) / c$$

$$\Delta t_{\text{backward}} = (\Delta x - v \Delta t_{\text{backward}}) / c$$

$$\Delta t_{\text{total}} = \Delta t_{\text{forward}} + \Delta t_{\text{backward}} = (2 \Delta x / c) \gamma^2$$

(Using time dilation:  $\Delta t_{\text{total}} = \Delta t_0 \gamma$ )

$$2 \Delta x_0 = 2 \Delta x \gamma$$

$\Delta x = \Delta x_0 / \gamma$  the length of the moving train is  
contracted!



# Length Contraction

“Moving objects shrink!”

Length of moving object measured using ruler that is not moving

$$L = L_0 \sqrt{1 - \frac{v^2}{c^2}}$$

Length in object's rest frame

# Example

# Length Contraction



Sue is carrying a pole 10 meters long. Paul is on a barn which is 8 meters long. If Sue runs quickly  $v=0.8c$ , can she ever have the entire pole in the barn?

Paul: The barn is 8 meters long, and the pole is only

$$L = L_0 \sqrt{1 - \frac{v^2}{c^2}} = 10 \sqrt{1 - .8^2} = 6 \text{ meters}$$

Sue: No way! This pole is 10 meters long and that barn is only

$$L = L_0 \sqrt{1 - \frac{v^2}{c^2}} = 8 \sqrt{1 - .8^2} = 4.8 \text{ meters}$$

Who is right?

A) Paul

B) Sue

C) Both

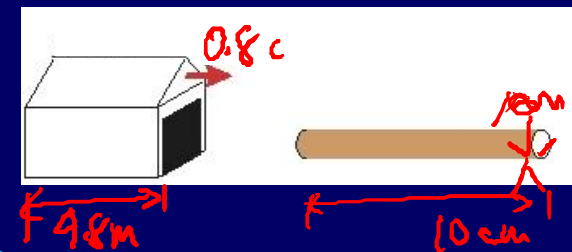
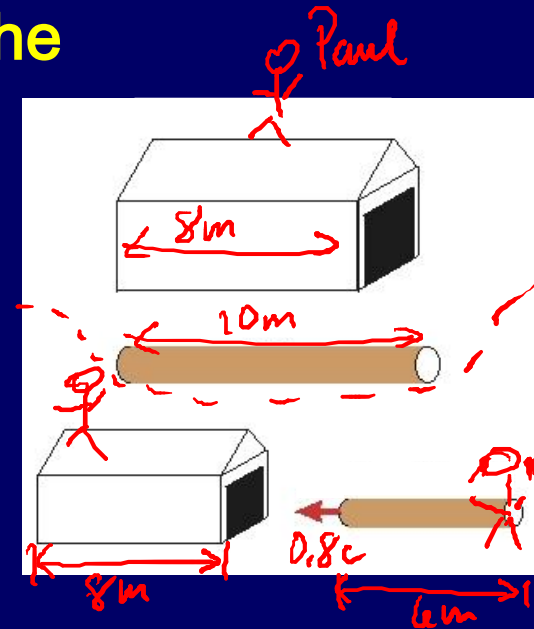



# ACT / Checkpoint 3

You're at the interstellar café having lunch in outer space - your spaceship is parked outside. A speeder zooms by in an identical ship at half the speed of light. From your perspective, their ship looks:

- (1) longer than your ship
- (2) shorter than your ship
- (3) exactly the same as your ship

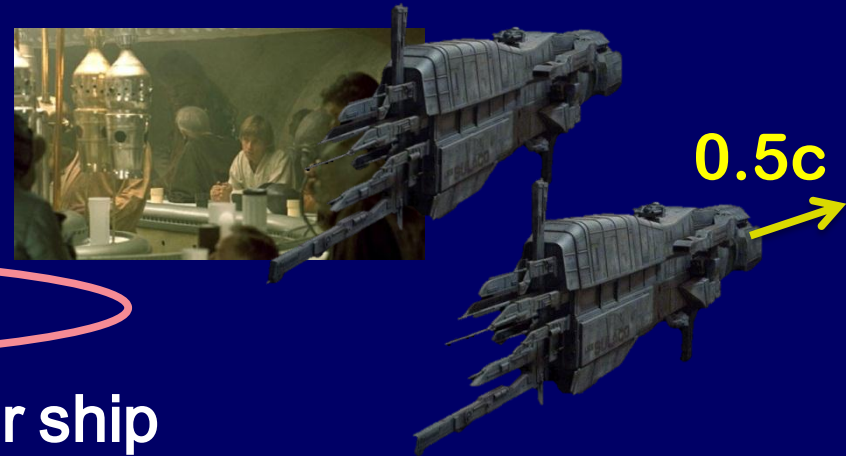

$$L = L_0 \sqrt{1 - \frac{v^2}{c^2}}$$

Always < 1

$$L_0 > L$$

In the speeder's reference frame

In your reference frame

# Time Dilation vs. Length Contraction

- **Time intervals between same two events:**

Consider only those intervals which occur **at one point in rest frame** “on train”.

- $\Delta t_0$  is in the reference frame at rest, “on train”. “**proper time**”
- $\Delta t$  is measured between same two events in reference frame in which train is moving, using clock that isn’t moving, “on ground”, in that frame.

$$\Delta t_0 = \Delta t \sqrt{1 - \frac{v^2}{c^2}}$$



$$\Delta t > \Delta t_0$$

Time seems longer from “outside”

- **Length intervals of same object:**

- $L_0$  is in reference frame where object is at rest “**proper length**”
- $L$  is length of moving object measured using ruler that is not moving.

$$L = L_0 \sqrt{1 - \frac{v^2}{c^2}}$$



$$L_0 > L$$

Length seems shorter from “outside”

# Consequence: Simultaneity depends on reference frame

## Aboard train

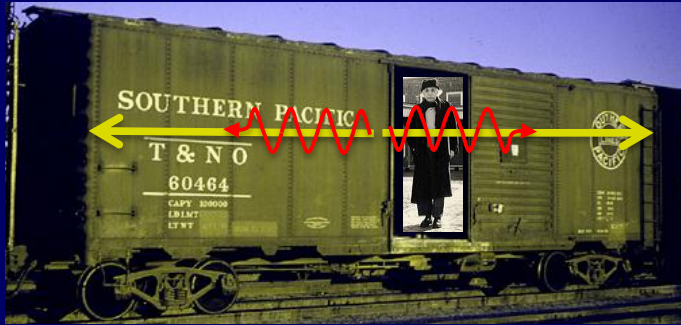

Light is turned on and arrives at the front and back of the train at the same time.

The two events,

- 1) light arriving at the front of the train and
  - 2) light arriving at the back of the train,
- are simultaneous.

## Train traveling to right with speed $v$

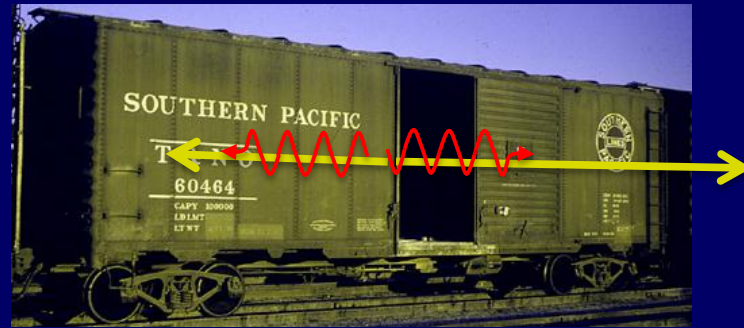

the observer on the ground sees :

Light arrives first at back of the train and then at the front of the train, because light travels at the same speed in all reference frames.

The same two events,

- 1) light arriving at the front of the train and
  - 2) light arriving at the back of the train,
- are NOT simultaneous.

**Therefore whether two events  
occur at the same time  
-simultaneity-  
depends on reference frame.**

# Relativistic Momentum

## Relativistic Momentum

$$p = \frac{mv}{\sqrt{1 - \frac{v^2}{c^2}}}$$

Note: for  $v \ll c$   $p = mv$

Note: for  $v = c$   $p = \text{infinity}$

## Relativistic Energy

$$E = \frac{mc^2}{\sqrt{1 - \frac{v^2}{c^2}}}$$

Note: for  $v = 0$   $E = mc^2$

Note: for  $v \ll c$   $E = mc^2 + \frac{1}{2} mv^2$

Note: for  $v = c$   $E = \text{infinity}$  (if  $m$  is not 0)

Objects with mass always have  $v < c$ !

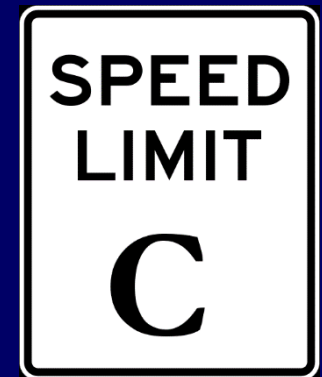

# Summary

- Laws of physics work in any inertial frame
  - “Simultaneous” depends on frame
  - Considering those time intervals that are measured at one point in the rest frame,  
Time dilates relative to proper time  
or moving clocks run slow.
  - Length contracts relative to proper length  
or moving objects are shorter.
  - Energy/Momentum conserved
- Laws of physics for  $v \ll c$  reduce to Newton's Laws