

The next two questions pertain to the situation described below.

A man stands a distance  $d = 240$  cm in front of a vertical flat mirror of length  $L = 45$  cm that is hung a distance  $y = 129$  cm above the ground as shown in the figure. The man's eyes are a distance  $h = 174$  cm above the ground.

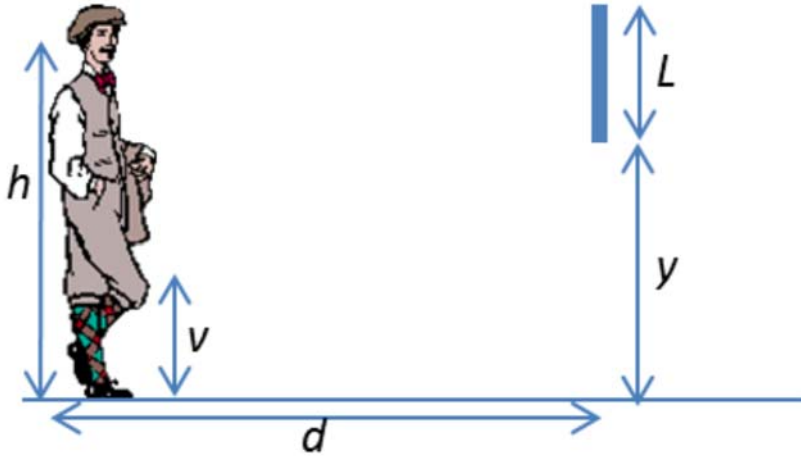

- 1) What is lowest point above the ground, that he can see his image reflection in the mirror?
  - a.  $v = 130$  cm
  - b.  $v = 84$  cm
  - c.  $v = 66$  cm
  - d.  $v = 150$  cm
  - e.  $v = 45$  cm
- 2) If the man takes a step closer to the mirror, the lowest point above the ground he can see his image reflected in the mirror
  - a. increase.
  - b. decrease.
  - c. remain the same.

The next three questions pertain to the situation described below.

A candle is placed in front of a diverging mirror with focal length  $f = -19$  cm as shown in the figure. The resulting image has a magnification  $m = 0.65$ .

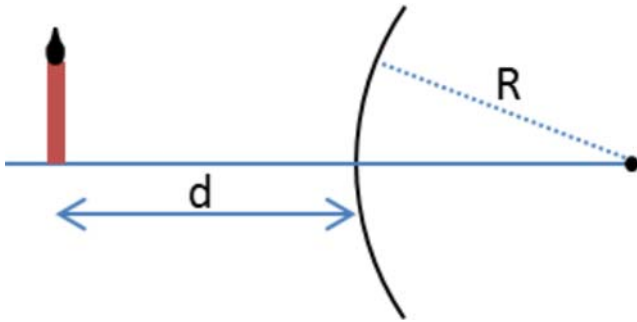

3) What is  $R$ , the radius of curvature of the mirror?

- a.  $R = 19$  cm
- b.  $R = 29$  cm
- c.  $R = 38$  cm

4) The resulting image is

- a. virtual.
- b. real.

5) What is  $d$ , the distance of the candle from the mirror?

- a.  $d = 10.2$  cm
- b.  $d = 29.2$  cm
- c.  $d = 31.4$  cm
- d.  $d = 12.3$  cm
- e.  $d = 48.2$  cm

The next four questions pertain to the situation described below.

A candle is placed before a converging lens as shown. The lens has a focal length of  $f = 2.4 \text{ cm}$ .

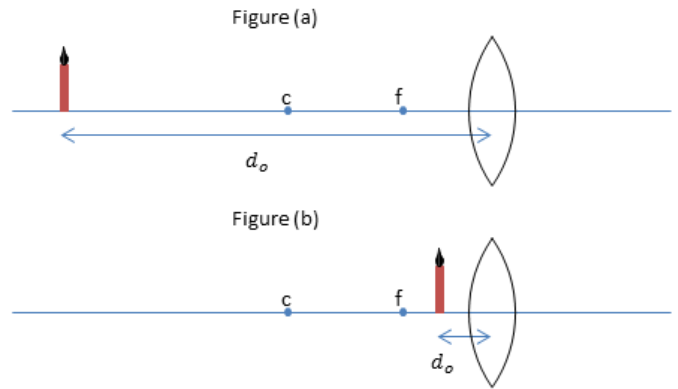

6) The candle is first placed at a distance  $d_o = 14.8 \text{ cm}$  as shown. The image is located at

- a.  $d_i = 2.07 \text{ cm}$
- b.  $d_i = 2.86 \text{ cm}$
- c. *no image is formed*

7) The resulting image is also

- a. *inverted*
- b. *neither*
- c. *upright*

8) Now the candle is placed at  $d_o = 1.2 \text{ cm}$ . Now the image is located at

- a.  $d_i = -2.4 \text{ cm}$
- b.  $d_i = -0.8 \text{ cm}$
- c. *no image is formed*

9) This new image is also

- a. *real*
- b. *neither*
- c. *virtual*

The next three questions pertain to the situation described below.

A candle is placed a distance  $d = 34$  cm in front of a diverging lens with focal length  $f_{Lens} = -19$  cm which is located a distance  $L = 25$  cm in front of a converging mirror with focal length  $f_{mirror} = 25$  cm as shown in the figure.

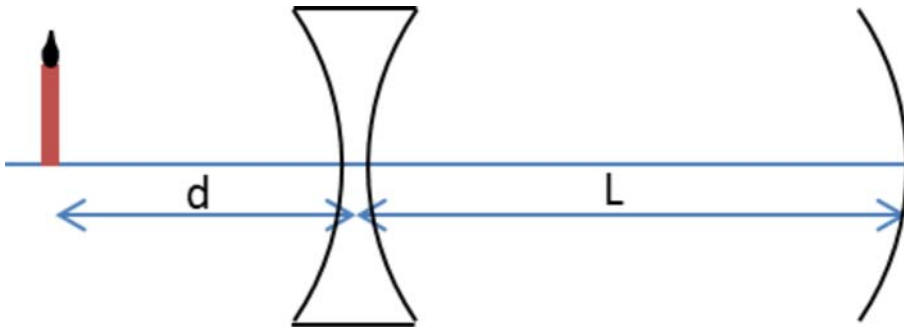

10) What is the location of the image of the candle due to the lens alone?

- a. 12.2 cm to the left of the lens
- b. 12.2 cm to the right of the lens

11) What is the location of the resulting image from the lens + mirror combination?

- a. 14.9 cm to the right of the mirror.
- b. 76.3 cm to the right of the mirror.
- c. 8.19 cm to the right of the mirror.
- d. 76.3 cm to the left of the mirror.
- e. 8.19 cm to the left of the mirror.

12) The final image from the lens mirror system is

- a. real.
- b. virtual.

The next two questions pertain to the situation described below.

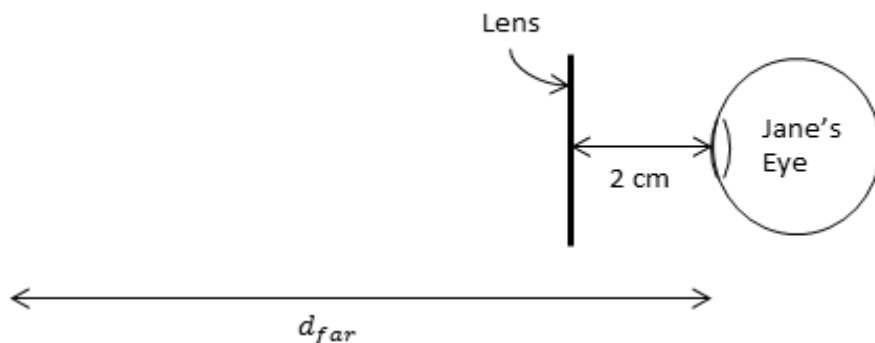

Jane is having trouble seeing through her glasses. Distant objects are blurry. Her corrective lenses sit 2 cm from her eyes as shown in the figure.

13) To correct her vision, Jane requires a

- a. *converging lens.*
- b. *diverging lens*
- c. *neither.*

14) Jane's far-point is  $d_{far} = 35 \text{ cm}$ . Remembering that a diopter is  $P = 1/f$  where  $f$  is measured in meters, what should her corrective lens prescription be?

- a. *-3 diopters*
- b. *2.9 diopters*
- c. *-2.9 diopters*
- d. *-2.7 diopters*
- e. *3 diopters*

15) Compare the focal length of a converging lens when it is in air, to the focal length of the same lens when it is in water.

- a.  $f_{air} > f_{water}$
- b.  $f_{air} = f_{water}$
- c.  $f_{air} < f_{water}$

The next two questions pertain to the situation described below.

A fish is swimming in water with index of refraction  $n = 1.3$  a distance  $h = 1.8$  m below the surface of the water as shown in the figure.

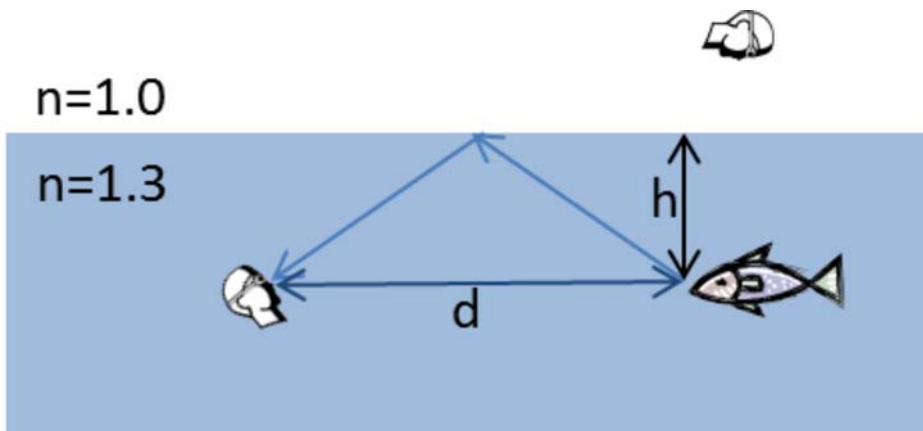

16) What is the apparent depth of the fish as observed by a person directly above the fish?

- a. 2.34 m below the surface of the water.
- b. 1.8 m below the surface of the water.
- c. 1.38 m below the surface of the water.

17) What is the closest distance  $d$  for which the person underwater can see a reflection of the fish from the air/water interface?

- a.  $d = 2.17$  m
- b.  $d = 4.33$  m
- c.  $d = 3.6$  m
- d.  $d = 5.63$  m
- e.  $d = 1.8$  m

The next two questions pertain to the situation described below.

Green light of wavelength  $\lambda = 532 \text{ nm}$  illuminates a pair of slits separated by a distance  $d = 0.42 \text{ mm}$ , as shown in the figure. An interference pattern is observed on a screen placed a distance  $L$  away.

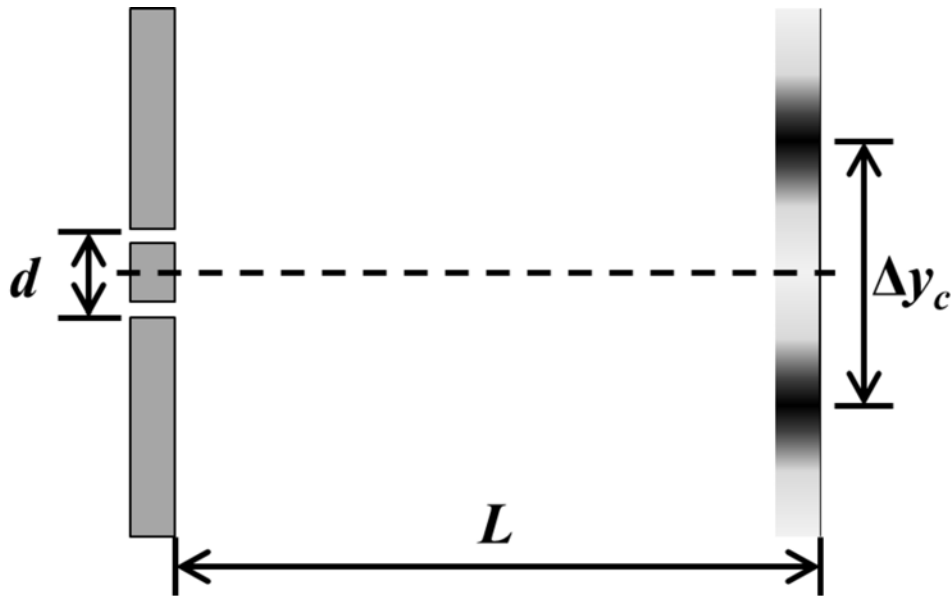

18) What is the distance  $L$  if the width of the central bright spot of the interference pattern is  $\Delta y_c = 1.9 \text{ cm}$ .

- a.  $L = 1.27 \text{ m}$
- b.  $L = 8.82 \text{ m}$
- c.  $L = 7.5 \text{ m}$
- d.  $L = 15 \text{ m}$
- e.  $L = 4.52 \text{ m}$

19) Which light wavelength of light would produce a larger central bright spot than the green light used in the above problem?

- a. Red-orange (  $635 \text{ nm}$  )
- b. Violet (  $405 \text{ nm}$  )

The next two questions pertain to the situation described below.

A pinhole camera with a circular aperture is used to make an image of two light sources separated by a distance  $\Delta y = 6.5$  cm and located a distance  $L = 125$  m away, as shown in the figure below. (Figure is not to scale.)

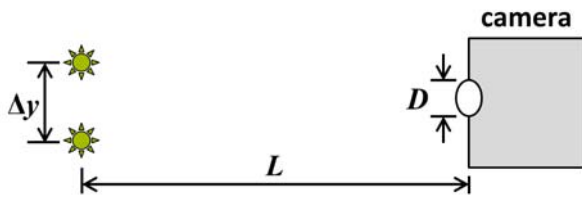

- 22) If the light sources emit light of wavelength  $\lambda = 577$  nm, what is the minimum aperture diameter  $D_{min}$  such that the two sources are just resolved by the pinhole camera?
- $D_{min} = 6.77$  mm
  - $D_{min} = 1.69$  mm
  - $D_{min} = 1.35$  mm
  - $D_{min} = 1.08$  mm
  - $D_{min} = 3.38$  mm
- 23) If the aperture of the camera is too small to resolve the two lights, which of the following changes would help improve the resolution?
- Replace the lights with ones that have a shorter wavelength.
  - Replace the lights with ones that have a longer wavelength.



A rectangular aperture of width  $w = 865 \mu\text{m}$  is illuminated by light of wavelength  $\lambda = 620 \text{ nm}$ . A diffraction pattern is shown on a screen a distance  $L = 3.9 \text{ m}$  away as shown in the figure.

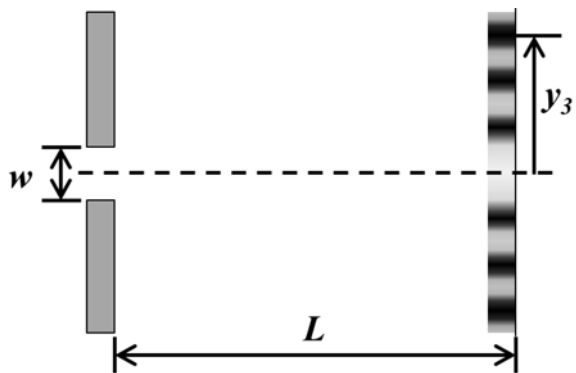

24) At what position  $y_3$  will the third-order ( $m = 3$ ) diffraction minimum be observed?

- a.  $y_3 = 8.39 \text{ mm}$
- b.  $y_3 = 41.9 \text{ mm}$
- c.  $y_3 = 2.1 \text{ mm}$
- d.  $y_3 = 3.35 \text{ mm}$
- e.  $y_3 = 21 \text{ mm}$

- 26) A diffraction grating has  $3.7 \times 10^5$  slits per meter. Which of the following values is closest to the maximum wavelength of incident light such that the fifth-order ( $m = 5$ ) bright fringe can still be seen?
- a. 541 nm
  - b. 764 nm
  - c. 649 nm

Answers

- 1. b
- 2. c
- 3. c
- 4. a
- 5. a
- 6. b
- 7. a
- 8. a
- 9. c
- 10. a
- 11. d
- 12. a
- 13. b
- 14. a
- 15. c
- 16. c
- 17. b
- 18. d
- 19. a
- 20. b
- 21. a
- 22. c
- 23. a
- 24. a
- 25. c
- 26. a

*The next two questions pertain to the following situation.*

An object (black arrow) is located in front of a *convex* spherical mirror of radius  $R = 35$  cm, as shown in the figure below. The tip of the arrow is located at  $(x_o, y_o) = (16 \text{ cm}, -6 \text{ cm})$  from the mirror.

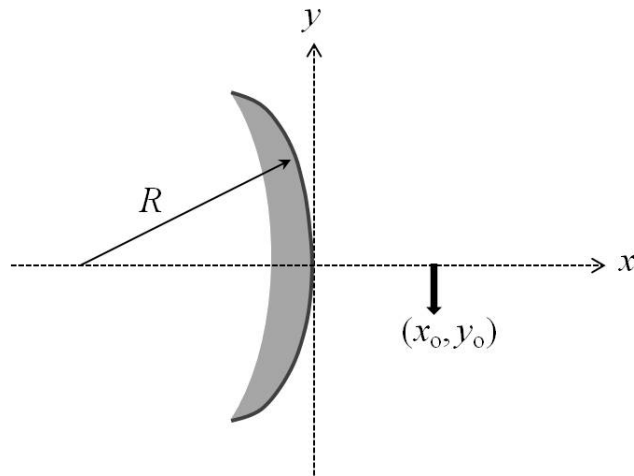

1. What is  $x_i$ , the  $x$ -coordinate of the image of the tip of the arrow?
  - a.  $x_i = -8.4 \text{ cm}$
  - b.  $x_i = -11.0 \text{ cm}$
  - c.  $x_i = +18.7 \text{ cm}$
  
2. The object arrow is now moved such that the *image* distance doubles. What is  $y_{i,\text{new}}$ , the new  $y$ -coordinate of the image of the tip of the arrow?
  - a.  $y_{i,\text{new}} = -3.13 \text{ cm}$
  - b.  $y_{i,\text{new}} = +0.16 \text{ cm}$
  - c.  $y_{i,\text{new}} = -0.27 \text{ cm}$
  - d.  $y_{i,\text{new}} = +6.35 \text{ cm}$
  - e.  $y_{i,\text{new}} = -12.7 \text{ cm}$

A laser emits light along the  $z$  axis with intensity  $I_0$  and *unknown* polarization. To measure the polarization, you place a linear polarizer in front of the light. As shown in the figure below, when the polarizer transmission axis is vertical (along the  $y$  axis) you measure the intensity of the transmitted light to be  $I_0/2$ . When it is tilted  $15^\circ$  from vertical, you measure an intensity of  $I_0/4$ .

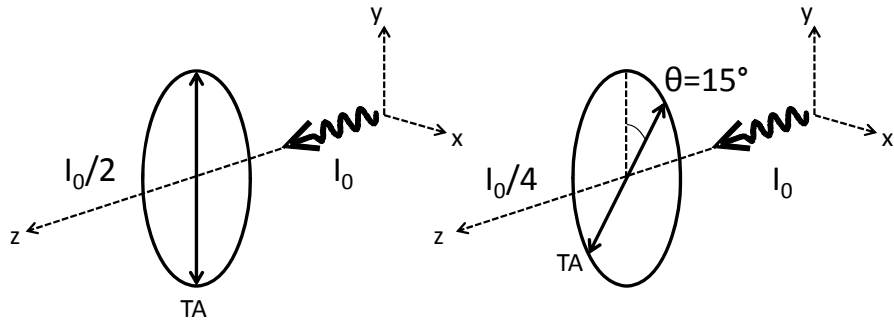

3. Which diagram of the  $x$ - $y$  plane best represents the polarization of the laser beam?

- a.
- b.
- c.
- d.
- e.

*The next three questions pertain to the following situation:*

Consider the figure below which shows a snapshot of an electromagnetic wave propagating in vacuum along the  $x$  axis. The wave is linearly polarized along the  $y$  axis and oscillates at a frequency  $f = 1.25 \times 10^{12}$  Hz. The light has an average intensity  $I = 0.5$  W/m<sup>2</sup>.

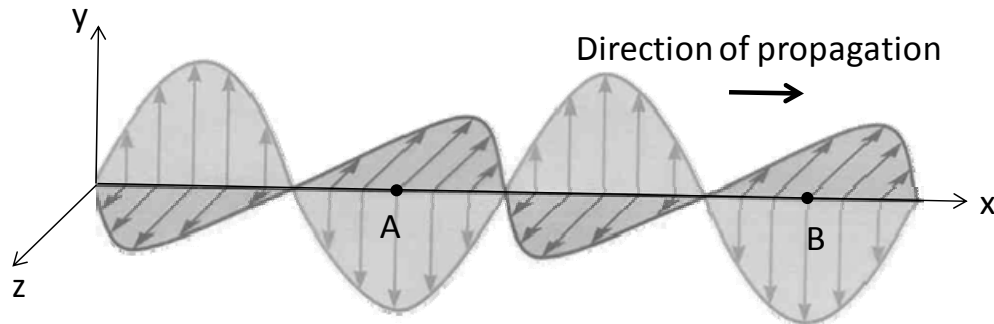

9. What is the magnitude of the electric field  $E$  at point A on the  $x$  axis at the instant shown?

- a.  $E = 0$  N/C
- b.  $E = 7.9$  N/C
- c.  $E = 19.4$  N/C

10. Along which direction does the magnetic field oscillate?

- a.  $x$  axis
- b.  $y$  axis
- c.  $z$  axis

11. What is the distance between points A and B?

- a.  $2.4 \times 10^{-4}$  m
- b.  $3.1 \times 10^{-2}$  m
- c.  $7.8 \times 10^{-3}$  m

13. A light ray traveling horizontally in air is incident on a prism made of glass with index of refraction  $n = 1.65$  as shown in the figure below. The emerging angle from the prism is as defined in the figure.

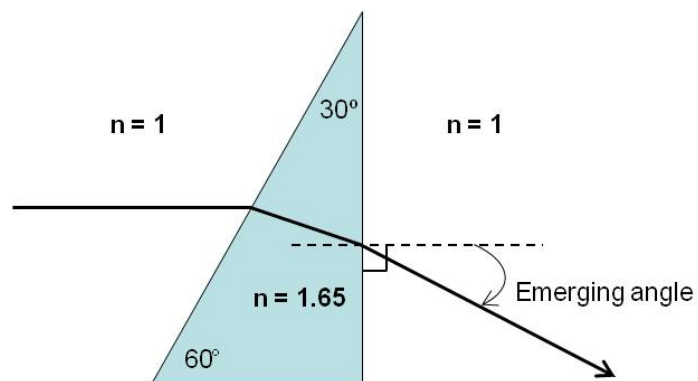

Now assume that the prism is replaced with another one of the same shape but with an index of refraction  $n' = 1.55$ . With respect to the original prism, the emerging angle is

- a. Larger
- b. Smaller
- c. Equal

*The next two questions pertain to the situation described below.*

A light source at the bottom of a swimming pool emits light at a wide range of angles, as shown in the figure below. The index of refraction of water is  $n = 1.35$ .

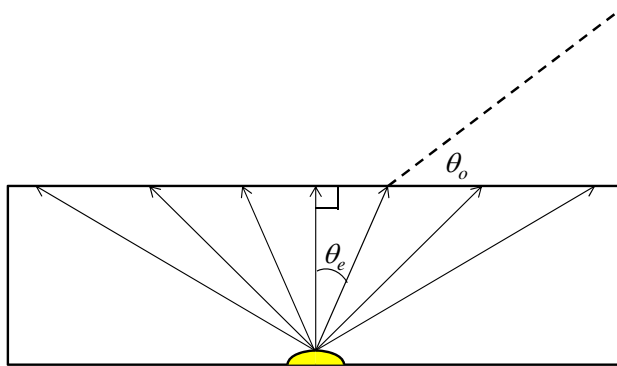

16. What is the maximum emission angle  $\theta_{e,\max}$  for which light is observed above the surface, assuming that the pool is as wide as it needs to be?

- $\theta_{e,\max} = 61.3^\circ$
- $\theta_{e,\max} = 55.1^\circ$
- $\theta_{e,\max} = 47.8^\circ$

17. Now consider a light ray emitted at an angle *larger* than  $\theta_{e,\max}$  as shown below. After reaching the surface of water, which of the following traces would it follow?

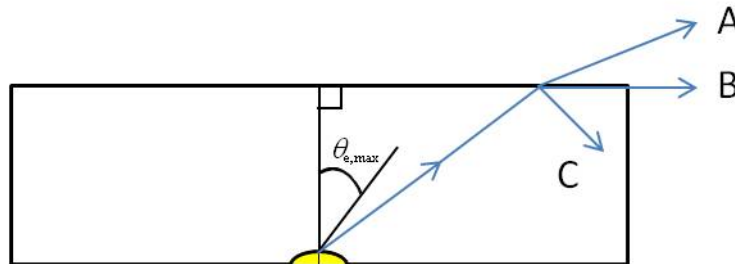

- Trace **A**
- Trace **B**
- Trace **C**

The following two questions refer to the figure below.

As shown in the figure below, an object (black arrow) sits in front of a diverging lens of focal length  $|f| = 13$  cm, at a distance  $s = 30$  cm from the lens.

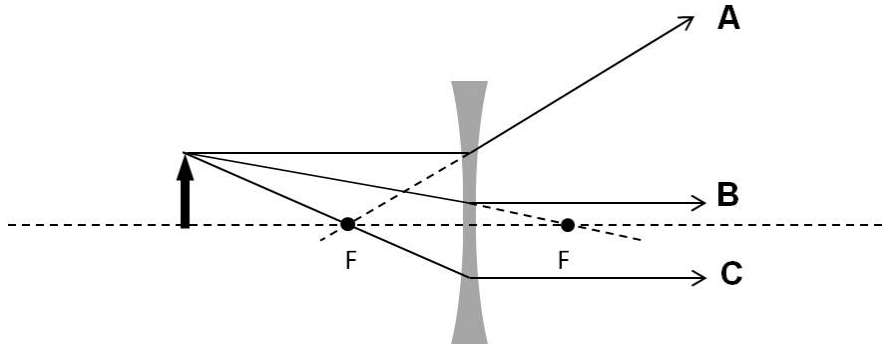

18. Which of the following rays drawn in the figure is *not* a valid principal ray?

- a. Ray **A**
- b. Ray **B**
- c. Ray **C**

19. If the object height is  $h = 8$  cm, what is the height of the image,  $h'$ ?

- a.  $h' = 2.4$  cm
- b.  $h' = 6.1$  cm
- c.  $h' = 10.3$  cm
- d.  $h' = 12.5$  cm
- e.  $h' = 19.2$  cm



*The next three questions pertain to the situation described below.*

Consider a system of two lenses as shown in the figure below. The first lens is a *diverging* lens located at  $x_1 = 0$  and has a focal length of  $|f_1| = 10$  cm. The second lens is a *converging* lens located at  $x_2 = 40$  cm and has a focal length of  $|f_2| = 14$  cm. The distance between the object (black arrow) and the first lens is  $d = 18$  cm.

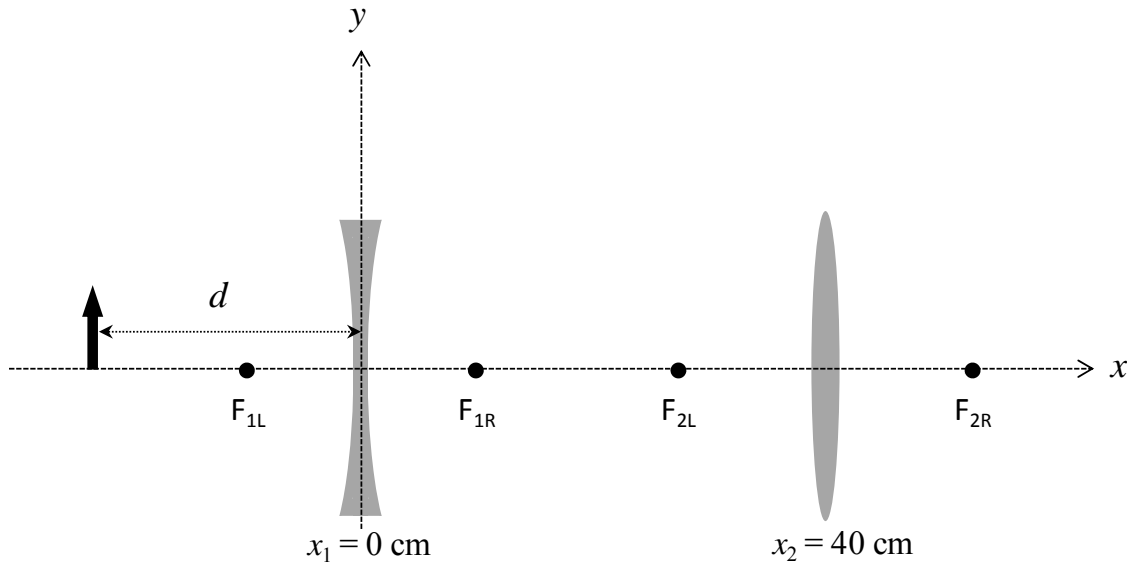

20. What is  $x_{i,\text{final}}$ , the x-coordinate of the final image formed by the two lenses?

- $x_{i,\text{final}} = -11.9$  cm
- $x_{i,\text{final}} = +15.7$  cm
- $x_{i,\text{final}} = +21.2$  cm
- $x_{i,\text{final}} = +24.0$  cm
- $x_{i,\text{final}} = +60.0$  cm

21. What is the nature of the final image in this system?

- Real, inverted, and reduced
- Real, upright, and enlarged
- Virtual, inverted, and enlarged
- Virtual, upright, and enlarged
- Virtual, upright, and reduced

*The next two questions pertain to the following situation:*

The distance between the center of the lens and the retina of an extremely nearsighted person is measured to be 27 mm long. Her far point is 10 cm from the center of the lenses of her eyes.

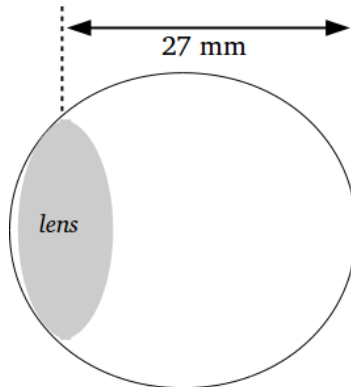

22. What is the focal length of the lens of this person's eyes?

- a.  $f_{eye} = +0.1$  cm
- b.  $f_{eye} = +1.3$  cm
- c.  $f_{eye} = -2.7$  cm
- d.  $f_{eye} = +2.1$  cm
- e.  $f_{eye} = -1.0$  cm

23. What is the power  $P_{lens}$  (in diopters) of the contact lens needed to correct this person's vision to focus a book placed 25 cm from her eyes without squinting? Assume the contact lens is placed directly next to the lens of the person's eye.

- a.  $P_{lens} = -6.00$  diopters
- b.  $P_{lens} = -2.93$  diopters
- c.  $P_{lens} = -8.46$  diopters
- d.  $P_{lens} = +5.06$  diopters
- e.  $P_{lens} = +3.24$  diopters

*The next two questions pertain to the following situation:*

Monochromatic light of wavelength 550 nm falls on two slits spaced 0.12 mm apart, forming fringes on a screen 0.75 m away.

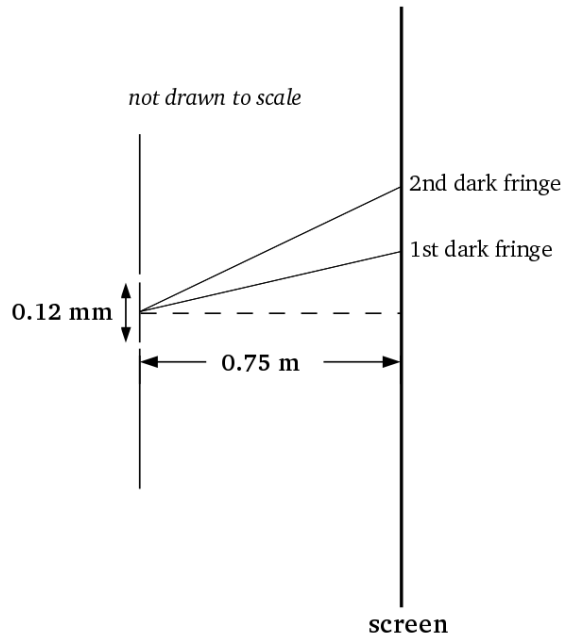

25. What is the distance,  $y_2 - y_1$ , between the first and second dark fringes located from the central axis? Assume the distance between the fringes on the screen is much smaller than the slit-to-screen distance (that is,  $y_2 - y_1 \ll 0.75$  m).

- a.  $y_2 - y_1 = 0.13$  mm
- b.  $y_2 - y_1 = 3.44$  mm
- c.  $y_2 - y_1 = 5.15$  mm
- d.  $y_2 - y_1 = 2.29$  mm
- e.  $y_2 - y_1 = 1.72$  mm

26. How would the distance between the first- and second-order dark fringes change if the distance between the two slits was decreased?

- a.  $y_2 - y_1$  would increase
- b.  $y_2 - y_1$  would not change
- c.  $y_2 - y_1$  would decrease

**Check to make sure you bubbled in all your answers.  
Did you bubble in your name, exam version and network-ID?**

## Exam 3 – answer key

1. a
2. c
3. d
4. b
5. c
6. c
7. c
8. b
9. c
10. c
11. a
12. e
13. b
14. a
15. a
16. c
17. c
18. c
19. a
20. e
21. a
22. d
23. a
24. b
25. b
26. a

1. A ray of light passes through three materials with different indices of refraction  $n_1$ ,  $n_2$ , and  $n_3$ , as shown below.

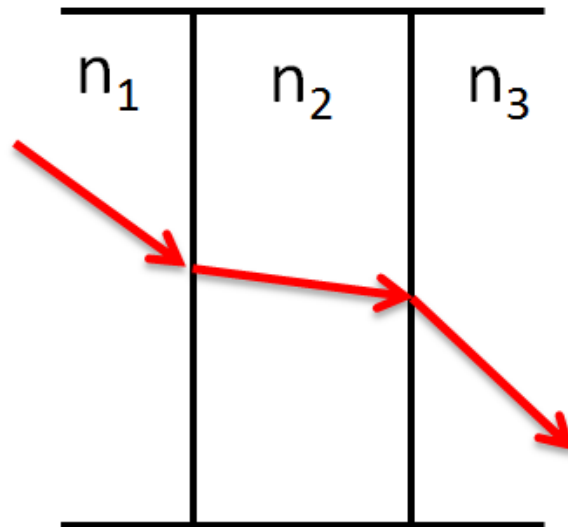

Which of the following statements is correct?

- a.  $n_1 > n_2$
- b.  $n_2 > n_3$
- c.  $n_1 = n_2$

2. A laser beam passes from air into a container of ethanol and refracts, as shown below. What is the speed of light in ethanol?

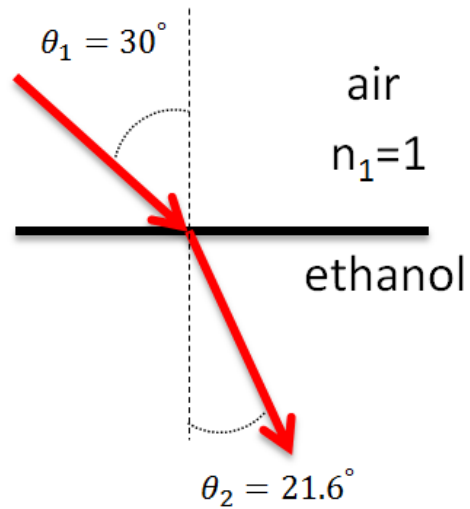

- a.  $2.11 \times 10^8$  m/s
- b.  $2.8 \times 10^8$  m/s
- c.  $3.0 \times 10^8$  m/s
- d.  $2.21 \times 10^8$  m/s
- e.  $4.07 \times 10^8$  m/s

3. A laser beam traveling in air enters and exits a piece of glass with an index of refraction of 1.5, as shown below.

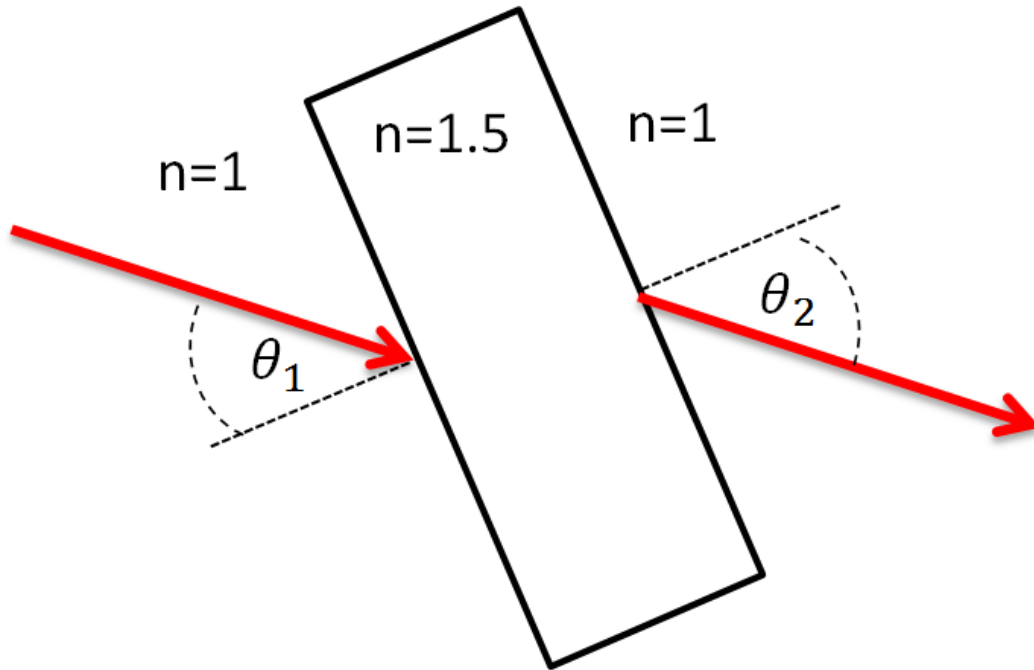

If the angle  $\theta_1=60$  degrees, what is  $\theta_2$ , the angle with respect to the normal on the side of the glass where the beam exits?

- a.  $\theta_2=30$  degrees
- b.  $\theta_2=60$  degrees
- c.  $\theta_2=35$  degrees

*The next two questions pertain to the following situation.*

A microscope is used to image two fluorescent markers that are attached to a strand of DNA. The markers emit light at 650 nm and are 1 mm from the lens in the microscope objective. The diameter of the microscope lens  $D=2$  mm.

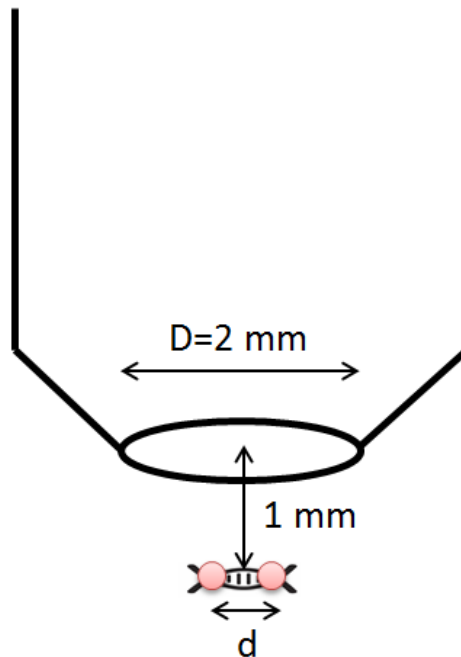

4. What is the minimum distance  $d$  between the markers for which they can be resolved?
- a. 400 nm
  - b. 790 nm
  - c. 1600 nm
  - d. 330 nm
  - e. 100 nm
5. What could you do to decrease  $d$ , i.e., improve the resolving power of the microscope?
- a. decrease  $D$
  - b. use markers that emit light at 532 nm
  - c. use markers that emit light at 800 nm



*The next two questions pertain to the following situation:*

As shown below, a ninja assassin hired by Physics 102 students is trying to sneak up on Professor DeMarco while he admires his hair in a mirror. The ninja is 10 m from the mirror, and Professor DeMarco is 1 m from the mirror. Professor DeMarco's eyes are 0.25 m below the top of the mirror.

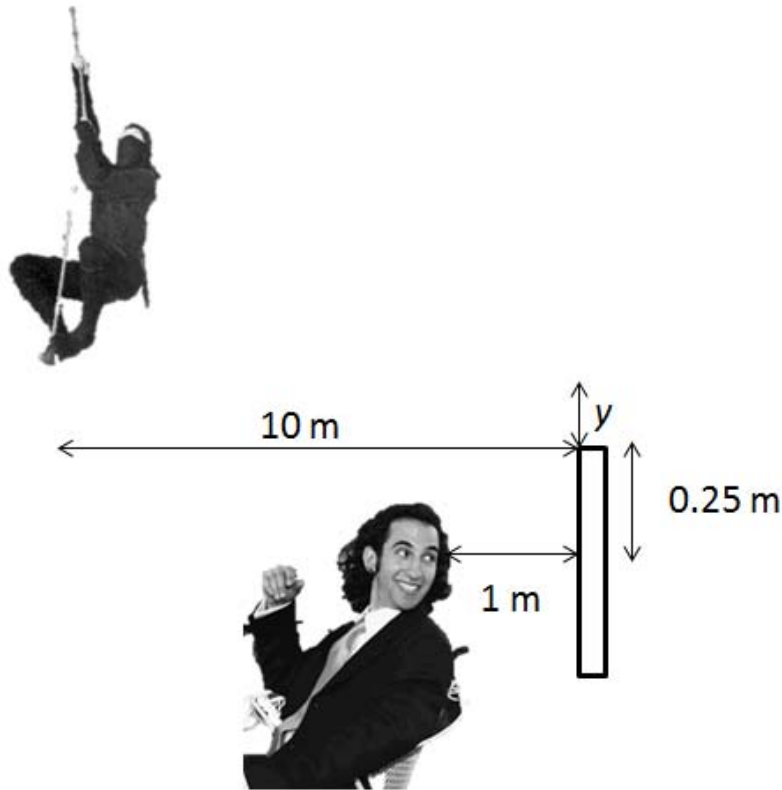

8. What is the minimum distance  $y$  that the ninja has to be above the top of the mirror so that Prof. DeMarco cannot see him?

- a. 2.5 m
- b. 0.025 m
- c. 0.25 m
- d. 10 m
- e. Professor DeMarco will be able to see the ninja for any height  $y$ .

9. If the ninja is visible in the mirror, what is the horizontal distance between Professor DeMarco and the image he sees of the ninja in the mirror?

- a. 1 m
- b. 10 m
- c. 11 m

*The next two questions pertain to the following situation.*

A double slit experiment with slit separation  $0.1 \text{ mm}$  is illuminated by light with wavelength  $\lambda$ . The second order bright fringe for constructive interference is located at  $y = 1 \text{ cm}$ , where  $y$  is measured from the dashed line.

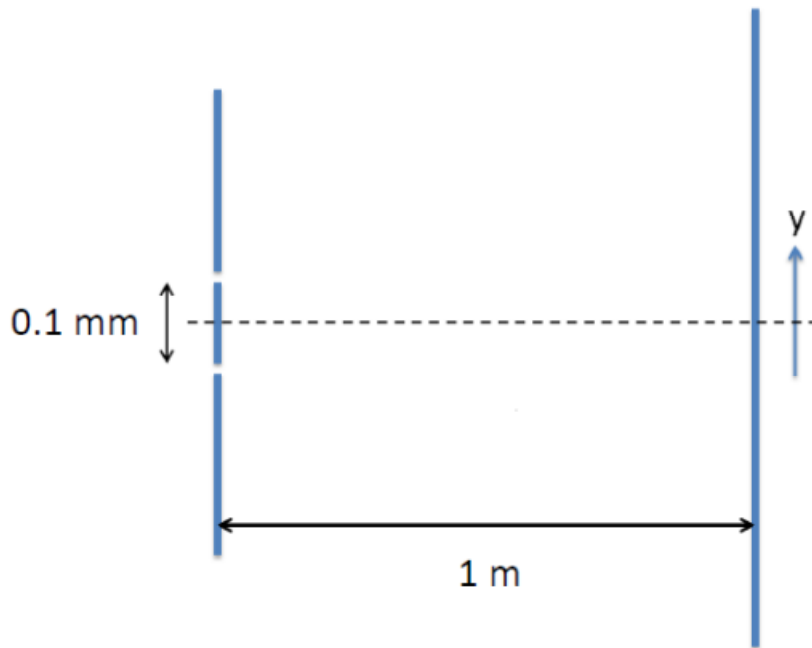

10. What is the wavelength  $\lambda$ ?

- a. 250 nm
- b. 333 nm
- c. 425 nm
- d. 500 nm
- e. 667 nm

11. The location  $y=0$  is always a point of destructive interference, independent of the slit separation.

- a. True
- b. False

*The next two questions pertain to the following situation:*

Light from a sodium lamp has two emission lines with wavelengths of 589.0 nm and 589.6 nm. The light from a sodium lamp is studied with a diffraction grating. The slits of the grating have a separation of  $2\ \mu\text{m}$ .

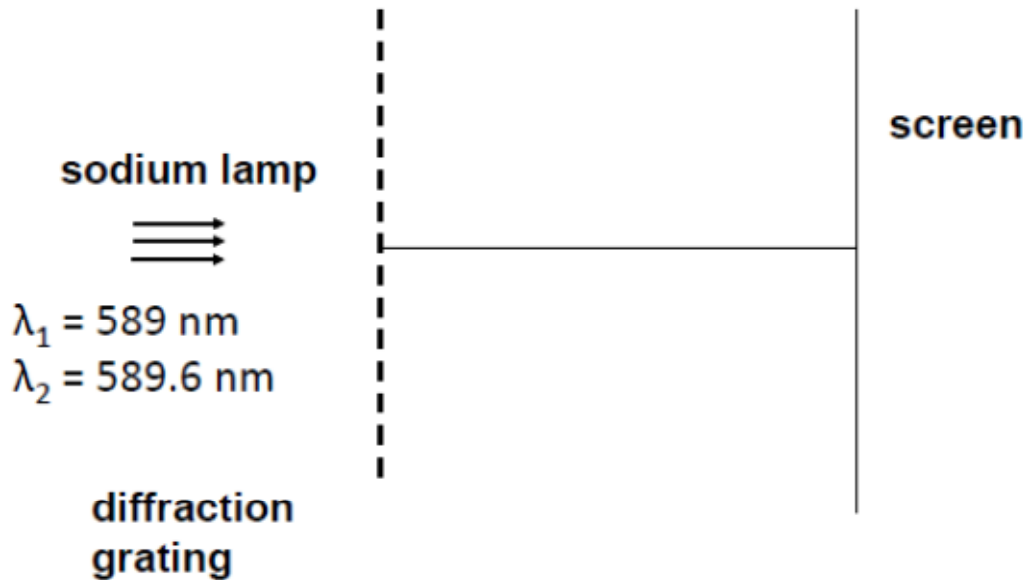

14. At what angle is the first-order maximum for the emission line with a wavelength of 589.0 nm observed?

- a.  $0^\circ$
- b.  $17.13^\circ$
- c.  $24.26^\circ$
- d.  $30.0^\circ$
- e.  $36.2^\circ$

15. What is the difference in angle between the second order maxima for the two wavelengths?

- a.  $0.018^\circ$
- b.  $0.037^\circ$
- c.  $0.043^\circ$
- d.  $0.009^\circ$
- e.  $0.056^\circ$

*The next two questions refer to the following situation:*

An optical fiber consists of a small cylinder of optically transparent plastic called the core, shown in gray, surrounded by a layer of different plastic called the cladding. The two plastics used for the core and the cladding have different indices of refraction. The index of refraction of the core is  $n=1.45$ . Light rays enter the fiber and propagate in the fiber as shown. The maximum angle  $\theta$  with which a ray can propagate in the core of the fiber and totally internally reflect from the cladding is 10 degrees.

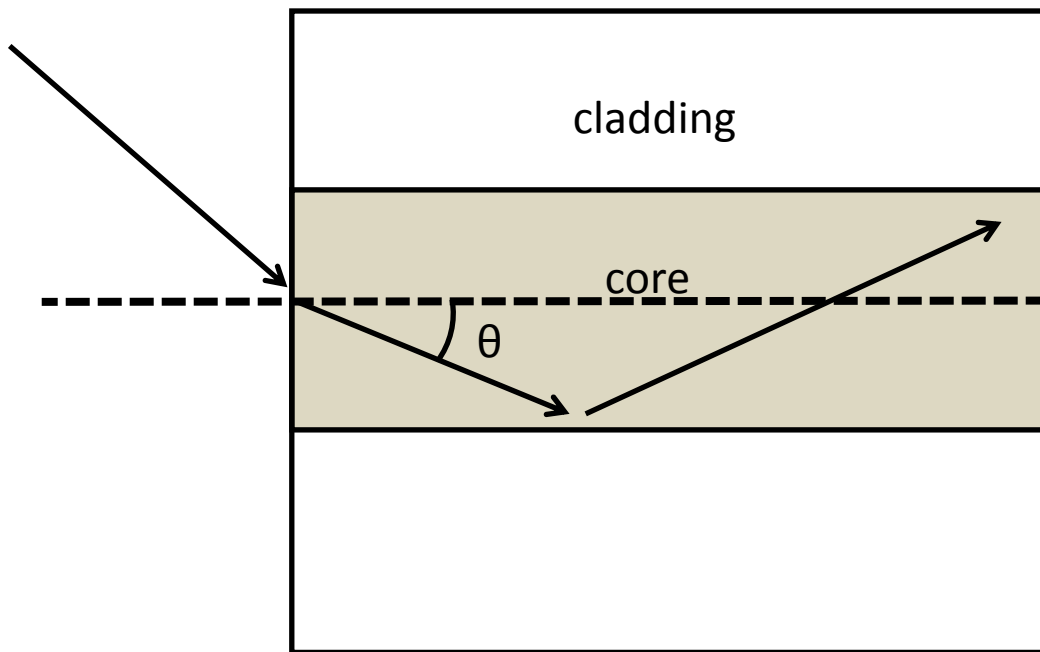

16. What is the index of refraction of the cladding?

- a. 1.450
- b. 1.428
- c. 1.472

17. The fiber is now placed in a bath of oil. The oil has an index of refraction of  $n=1.5$ . Which of the following statements is true for light that travels in the core at a  $\theta$  larger than 10 degrees?

- a. The light will exit from the core to the cladding and then from the cladding into the oil.
- b. The light will reflect from the surface between the core and the cladding and stay in the core.
- c. The light will exit from the core but totally internally reflect from the surface between the oil and cladding.

*The following two questions refer to the following situation.*

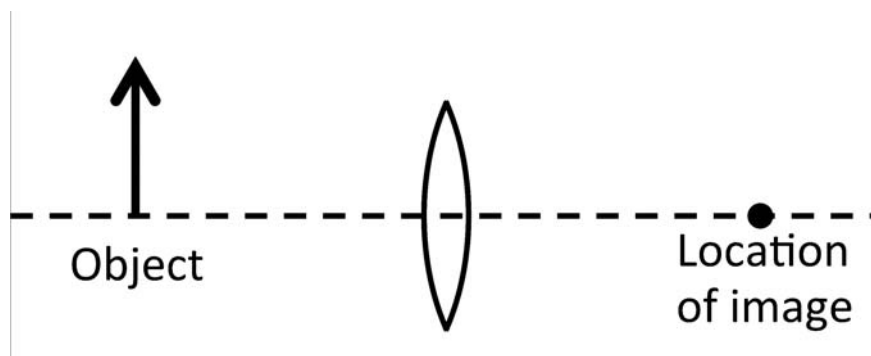

18. Where must one put an object with respect to the convex lens (which has focal length  $f$ ), so that the image is at the same distance from the lens as the object?

- a.  $d_{\text{obj}} = \frac{1}{2}f$
- b.  $d_{\text{obj}} = f$
- c.  $d_{\text{obj}} = 2f$

20. A two-lens apparatus consists of a convex lens with focal length  $f_1 = +5$  cm and a concave lens with focal length  $f_2 = -10$  cm. The lenses are separated by  $L = 30$  cm.

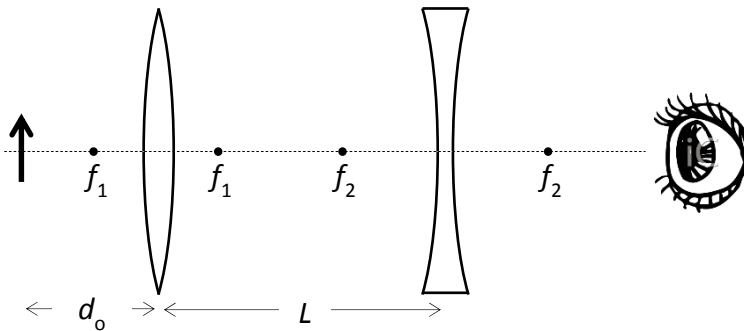

If an object is placed a distance  $d_o = 15$  cm from the convex lens, where is the image that the person (eyeball) sees?

- 6.9 cm to the left of the concave lens
- 6.9 cm to the right of the concave lens
- 18 cm to the left of the concave lens
- 18 cm to the right of the concave lens
- 22.5 cm to the left of the concave lens

21. A shaving mirror has a  $+20$  cm focal length. How far,  $d_{\text{face}}$ , must your face be from the mirror in order that your image is twice as large as your face?

- $d_{\text{face}} = 10$  cm
- $d_{\text{face}} = 20$  cm
- $d_{\text{face}} = 40$  cm
- $d_{\text{face}} = 60$  cm
- It is not possible to form an image that is twice as large as your face.

22. An object is in front of a shiny spherical surface that is a convex mirror. The letter “C” marks the center of curvature. Which of these ray diagrams correctly describes the image location?

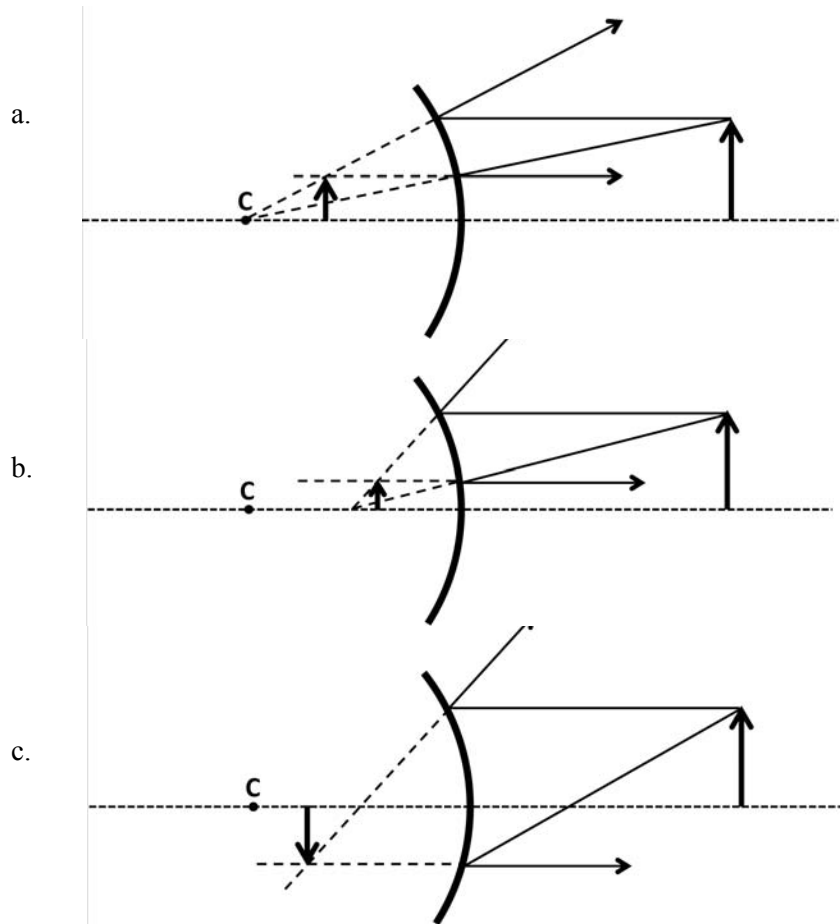

23. The diameter of the human eye is about 2.5 cm. One college student can focus on objects that are 10 cm in front of her face. What is the focal length,  $f$ , of her eye's lens when she is doing that?

- a.  $f = -5.00$  cm
- b.  $f = -3.33$  cm
- c.  $f = +1.25$  cm
- d.  $f = +2.00$  cm
- e.  $f = +2.50$  cm

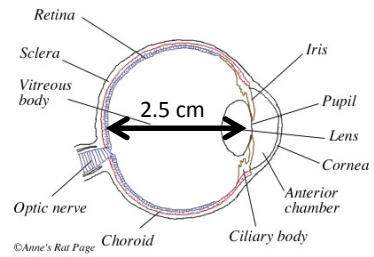

24. When you are young, your near point is 25 cm. Suppose an older person's near point has increased to 60 cm. What strength reading glasses, in diopters, must this person buy to regain the original 25 cm near point?

- a. 0.42 diopters
- b. 1.40 diopters
- c. 2.33 diopters
- d. 3.33 diopters
- e. 5.67 diopter

**Check to make sure you bubbled in all your answers.  
Did you bubble in your name, exam version and network-ID?**



## KEY

1. b
2. d
3. b
4. a
5. b
6. b
7. e
8. a
9. c
10. d
11. b
12. c
13. b
14. b
15. c
16. b
17. a
18. c
19. c
20. a
21. a
22. b
23. d
24. c

*The next two questions pertain to the following situation.*

A double slit experiment with slit separation  $0.2\text{ mm}$  is illuminated by light with wavelength  $\lambda$ . The third order bright fringe for constructive interference is located at  $y = 3\text{ cm}$ , where  $y$  is measured from the dashed line.

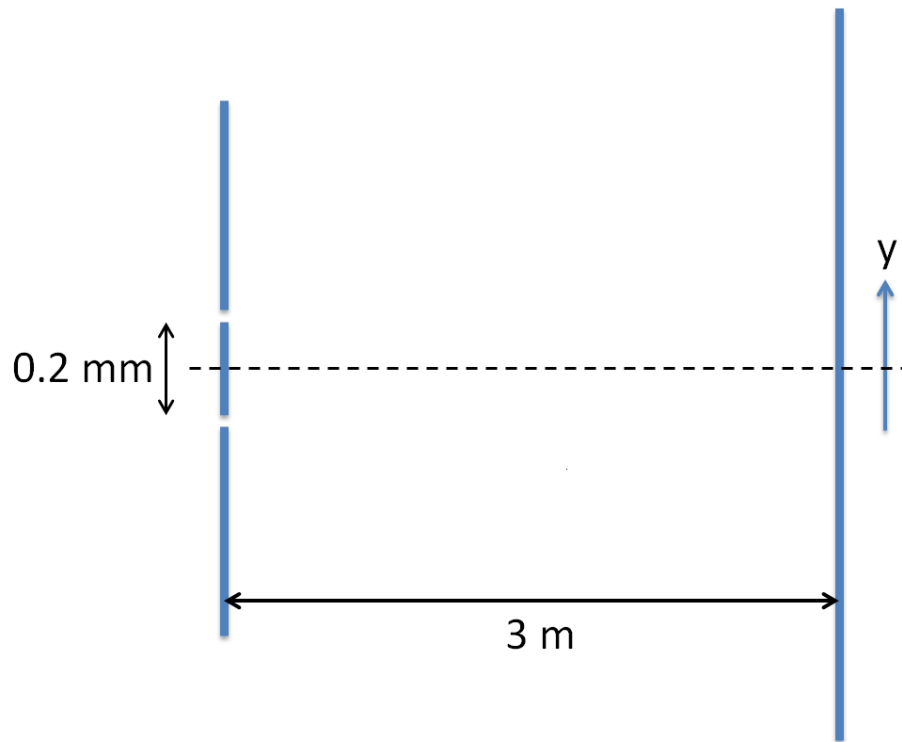

1. What is the wavelength  $\lambda$ ?
  - a. 233 nm
  - b. 340 nm
  - c. 450 nm
  - d. 566 nm
  - e. 667 nm
  
2. The location  $y=0$  is always a point of constructive interference, independent of the slit separation.
  - a. True
  - b. False

*The next two questions pertain to the following situation.*

The third order bright fringe for constructive interference for a diffraction grating with a screen 3 m away is located at  $y = 10.4$  cm when illuminated with light of wavelength  $\lambda = 420$  nm. The vertical distance  $y$  is measured from the dashed horizontal line.

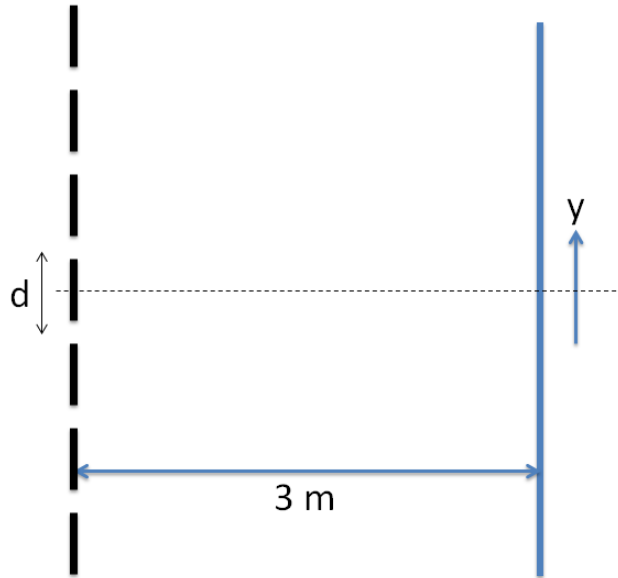

5. What is the slit separation of the diffraction grating?

- a.  $36.3 \mu\text{m}$
- b.  $50.2 \mu\text{m}$
- c.  $61.5 \mu\text{m}$
- d.  $72.2 \mu\text{m}$
- e.  $80.8 \mu\text{m}$

6. The wavelength of the light is changed by immersing the diffraction grating experiment in a transparent medium with index of refraction  $n = 1.31$ . What is new vertical distance  $y'$  of the third order bright fringe for constructive interference?

- a. 10.1 cm
- b. 13.1 cm
- c. 7.9 cm

*The next two questions pertain to the following situation.*

The critical angle for total internal reflection from a prism with index of refraction  $n_1 = 2.5$  is  $\theta_c = 33^\circ$ .

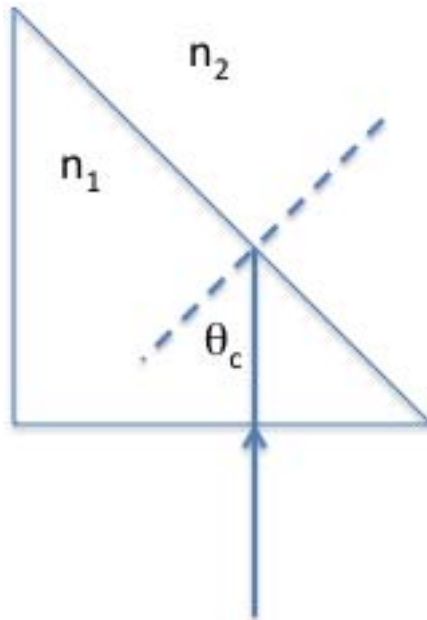

7. What is the index of refraction ( $n_2$ ) of the material in which the prism is immersed?
- a. 2.65
  - b. 1.78
  - c. 1.53
  - d. 1.36
  - e. 1.22
8. The index of refraction of the prism remains the same while the index of refraction of the outside material decreases. The critical angle
- a. increases.
  - b. decreases.
  - c. remains the same.

10. A person is standing at the edge of a pool watching the sun set, as shown in the figure below. The surface of the water acts like a plane mirror. Which picture best shows where the image of the sun is formed by the reflection from the surface of the water?

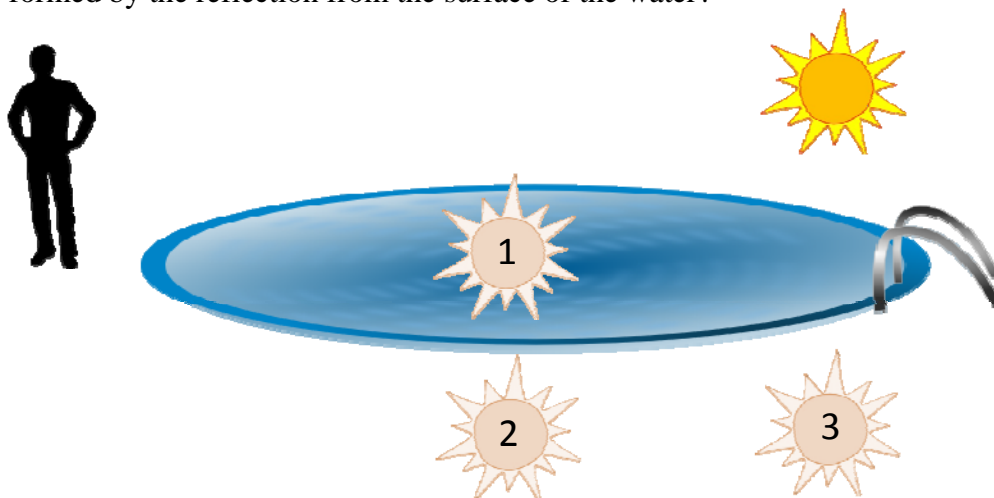

- a. 1
- b. 2
- c. 3

13. As shown in the figure below, the mirror that forms images for the Hubble space telescope is 2.4 m in diameter. What is the minimum distance  $d$  between two galaxies that are 100 light-years away in order for the telescope to resolve them and form two distinct images? You may assume that the telescope samples light with a 500 nm wavelength. One light-year is approximately  $9.5 \times 10^{15}$  m.

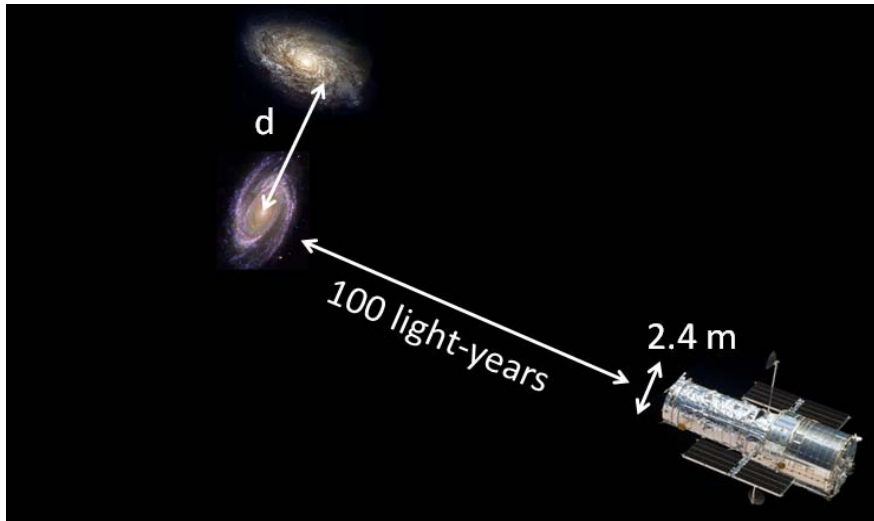

- a.  $d = 1.3 \times 10^6$  m
- b.  $d = 2.4 \times 10^{11}$  m
- c.  $d = 9.3 \times 10^{11}$  m
- d.  $d = 3.8 \times 10^{20}$  m
- e.  $d = 4.5 \times 10^{20}$  m

17. An object is placed 25 cm in front of a spherical mirror of unknown focal length. The image forms at 37.5 cm on the same side of the mirror. What is the focal length of the mirror?

- a.  $f = -75$  cm
- b.  $f = -10$  cm
- c.  $f = +5$  cm
- d.  $f = +15$  cm
- e.  $f = +25$  cm

18. An arrow is placed in front of a convex mirror. The focal point  $f$  and the center of curvature  $C$  are indicated in the diagrams below. Identify the ray diagram that correctly traces the path of a principal ray.

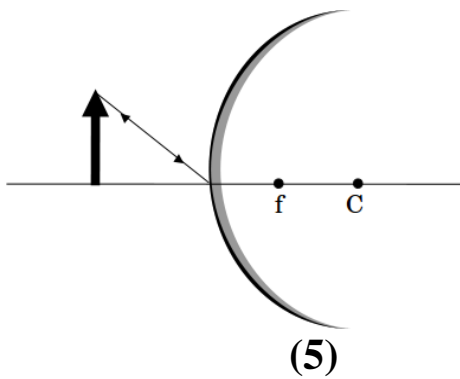
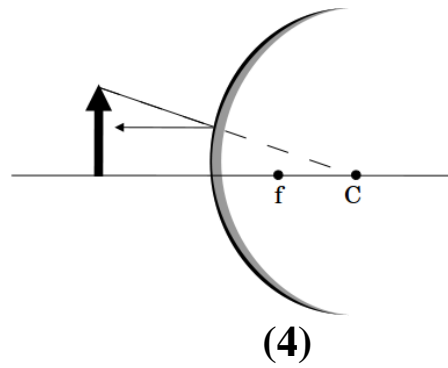
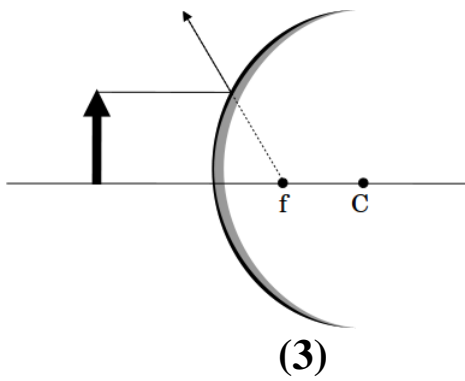
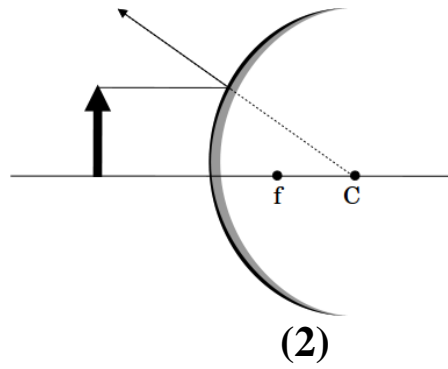
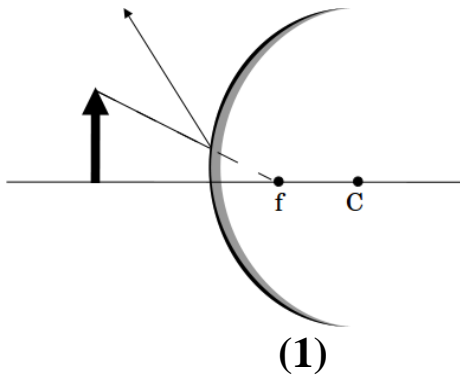

- a. 1
- b. 2
- c. 3
- d. 4
- e. 5



*The next three questions pertain to the following situation.*

An object is placed 3 cm in front of a diverging lens with focal length  $f = -7$  cm.

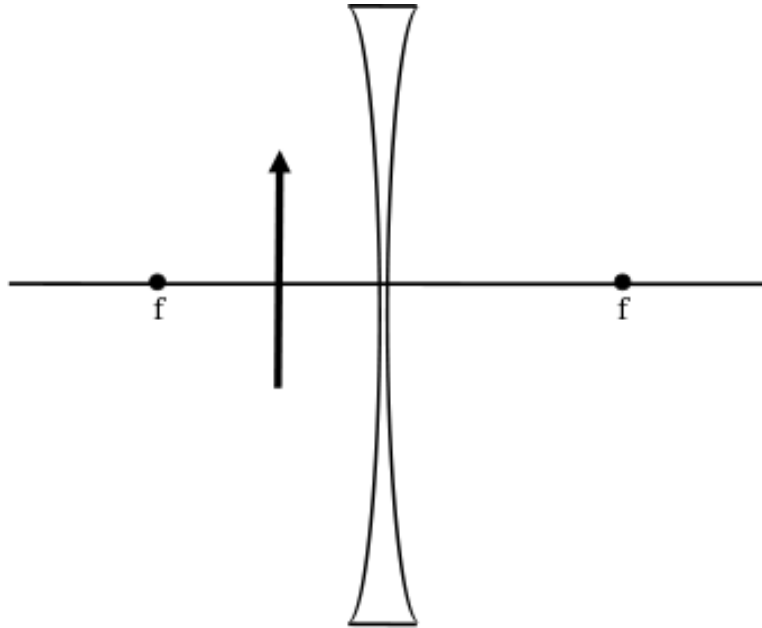

19. What is the magnification of the resulting image?

- a. -4.3
- b. -0.7
- c. +0.7
- d. +2.0
- e. +4.3

20. Is the image upright or inverted?

- a. upright
- b. inverted

21. Is the image real or virtual?

- a. real
- b. virtual

*The next two questions pertain to the following situation.*

A diverging lens of focal length  $f_d = -15$  cm is placed a distance  $D = 5$  cm to the left of a converging lens of focal length  $f_c = +10$  cm. An object is placed 30 cm to the left of the diverging lens.

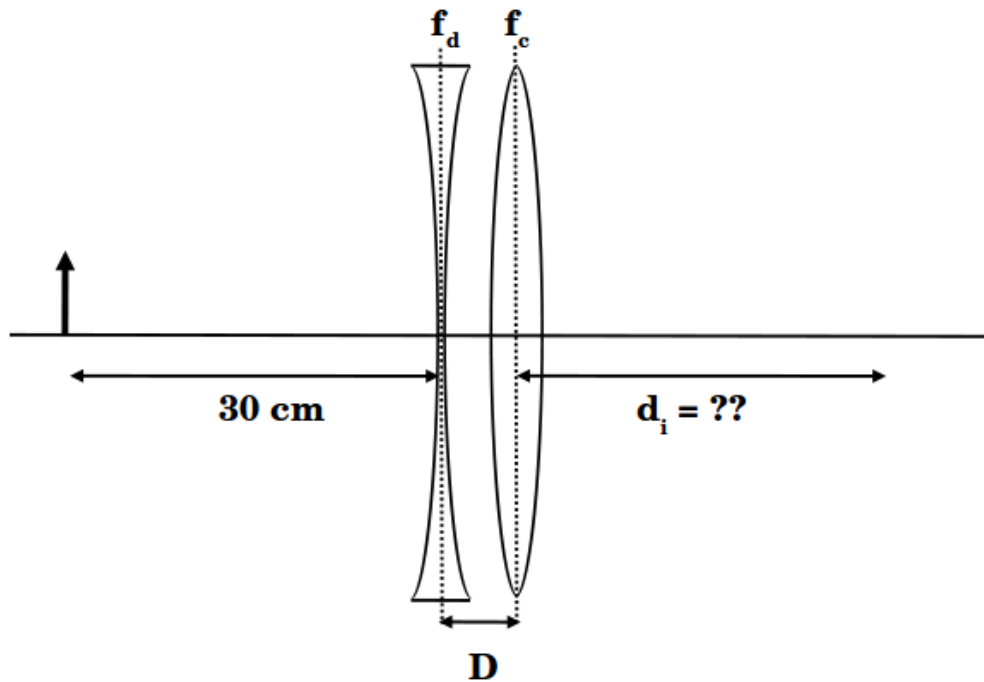

22. Where is the final image of the two-lens system, indicated by the distance  $d_i$  in the picture above?

- a. +30 cm
- b. +10 cm
- c. +5 cm
- d. -20 cm
- e. -45 cm

23. The diverging lens is held fixed, while the distance  $D$  is increased by moving the converging lens to the right. How does the size of the image formed by the two-lens system change?

- a. enlarged
- b. reduced
- c. no change

24. A farsighted person is unable to focus objects located 30 cm or closer from his eyes. What power lens is required for the person to clearly read a book located 22 cm in front of his eyes?

- a. 0.8 diopters
- b. 13 diopters
- c. 3.2 diopters
- d. 7.9 diopters
- e. 1.2 diopters

25. A nearsighted person cannot see clearly past 300 cm. What is the focal length of the lens required to correct her vision?

- a. 25 cm
- b. -50 cm
- c. -300 cm

**Check to make sure you bubbled in all your answers.  
Did you bubble in your name, exam version and network-ID?**

## KEY

1. e
2. a
3. c
4. e
5. a
6. c
7. d
8. b
9. b
10. c
11. b
12. e
13. b
14. a
15. a
16. d
17. d
18. c
19. c
20. a
21. b
22. a
23. b
24. e
25. c

1. For the circular mirror pictured below, which of the following rays is drawn correctly? The radius of curvature of the mirror is  $R$ .

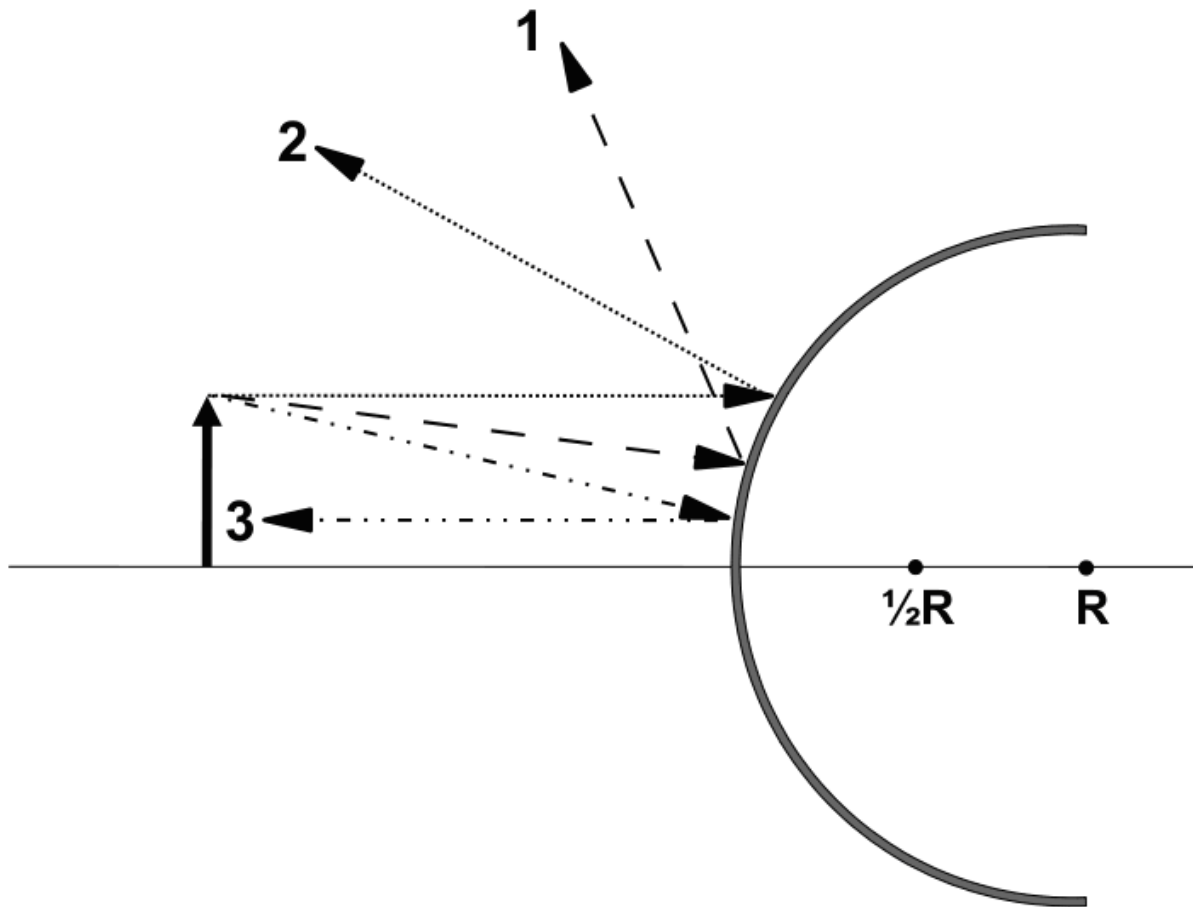

- a. 3
- b. 1
- c. 2

*The next two questions pertain to the same situation.*

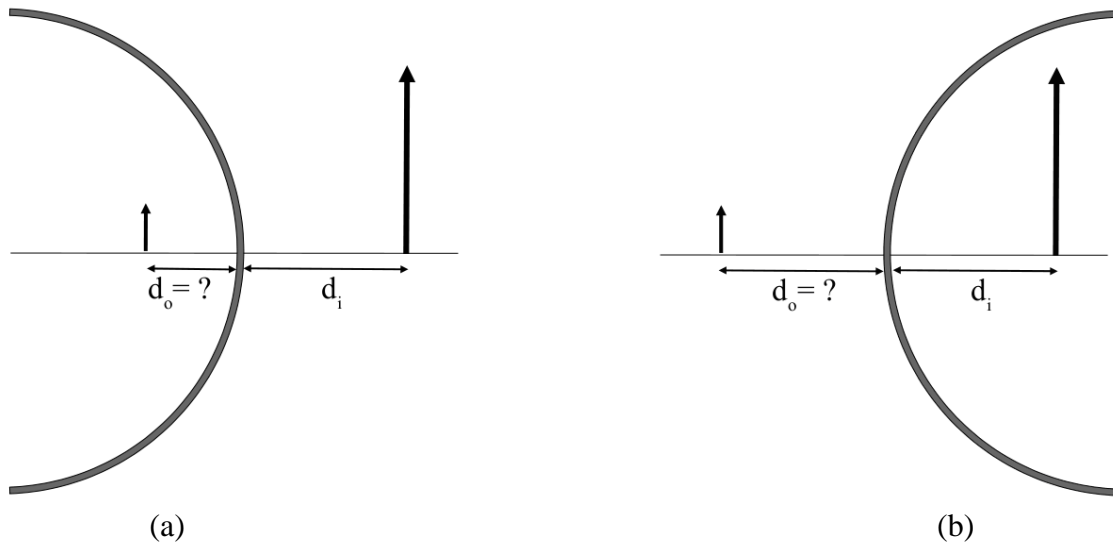

2. A virtual image is formed 15 cm behind a mirror. The image's magnification  $m$  is measured to be +5. Determine whether the mirror is concave or convex.

- a. convex
- b. concave

3. What is the radius of curvature of the mirror?

- a. 5 cm
- b. 15 cm
- c. 7.5 cm

*The next three questions pertain to the same situation.*

Two lenses are separated by 18 cm. Lens #1 is convergent and has a focal length of 5 cm. Lens #2 is divergent and has a focal length of -7 cm. An object (arrow) is located 10 cm to the left of Lens #1.

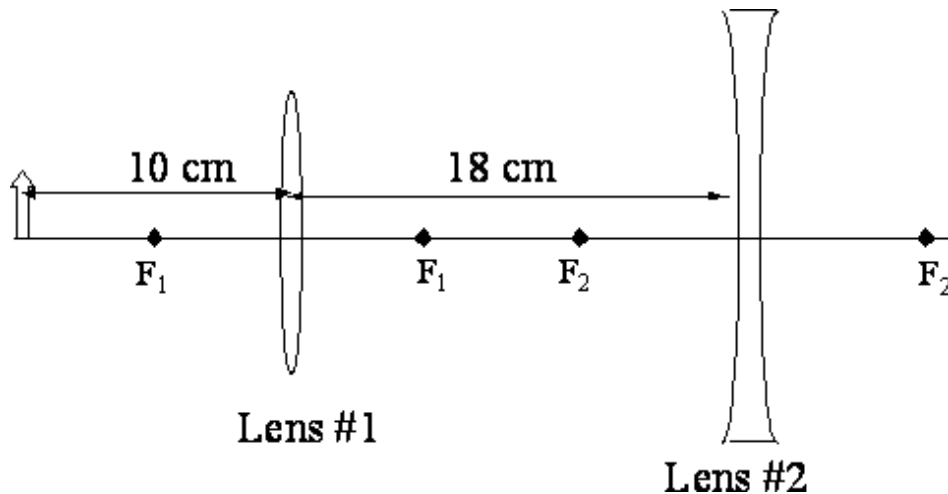

4. If lens #2 were not present, the image formed by lens #1 would be:

- inverted relative to the object
- upright relative to the object

5. Where is the final image of the pair of lenses?

- to the right of lens #2 and less than 7cm away from lens #2
- to the left of lens #2 and more than 7 cm away from lens #2
- to the right of lens #2 and more than 7 cm away from lens #2
- infinity
- to the left of lens #2 and less than 7cm away from lens #2

6. The final image formed by the pair of lenses is:

- larger than object
- the same height as the object
- shorter than the object

*The next two questions pertain to the same situation.*

Two sister stars are found to emit the same average wavelength  $\lambda = 230 \text{ nm}$  and are located a distance  $d = 3.75 \times 10^{18} \text{ m}$  away from Earth.

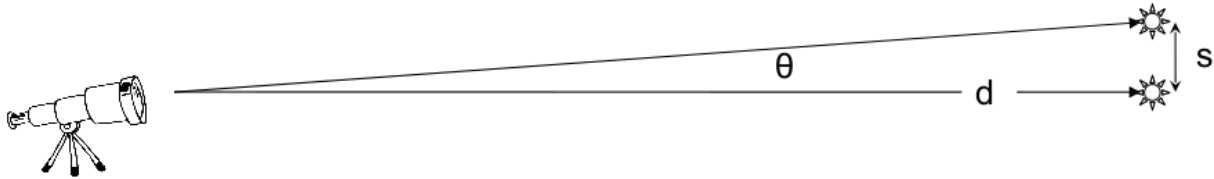

7. The stars are estimated to be separated by  $s = 4.50 \times 10^{11} \text{ m}$ . What minimum diameter of telescope lens is needed to resolve their images?

- a. 5.4 m
- b. 4.1 m
- c. 1.9 m
- d. 0.8 m
- e. 2.3 m

8. About how long does it take for light to reach Earth after leaving one of these stars?

- a.  $1.25 \times 10^{10}$  seconds = 396 years
- b.  $6.31 \times 10^7$  seconds = 2 years
- c.  $3.89 \times 10^{10}$  seconds = 1232 years
- d.  $4.67 \times 10^9$  seconds = 148 years
- e.  $2.18 \times 10^{10}$  seconds = 690 years

9. Which of the following statements is NOT true about light?

- I. Light waves do not require a medium to carry energy.
- II. The electric and magnetic fields of a light wave are mutually inducing.
- III. Light is a longitudinal wave.

- a. II
- b. III
- c. I



10. A person stands 3.6 m in front of a wall that is covered floor-to-ceiling with a plane mirror. Her eyes are 1.8 m above the floor. She holds a flashlight between her feet and manages to point it at the mirror. At what angle of incidence must the light strike the mirror so the light will reach her eye?

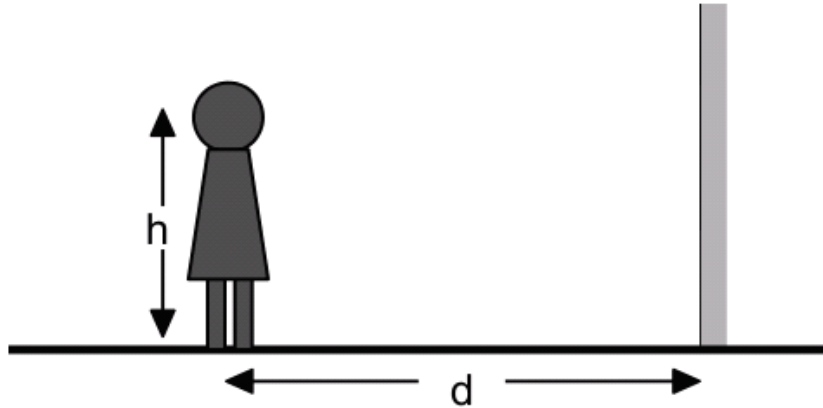

- a.  $37^\circ$
- b.  $82^\circ$
- c.  $0^\circ$
- d.  $25^\circ$
- e.  $14^\circ$

11. What is the near point for a person's unaided eye if he needs a corrective lens with a power of +1.5 diopters to read a book held 25 cm away from his eyes?

- a. 67 cm
- b. 50 cm
- c. 25 cm
- d. 40 cm
- e. 17 cm

*The next five questions refer to the following situation:*

A laser that emits light with a wavelength of 1064 nm is used to cut a steel plate. A polarizer is mounted after the laser output with its transmission axis along the y direction. The power after the polarizer is 100 W. The radius of the laser beam is 0.5 mm.

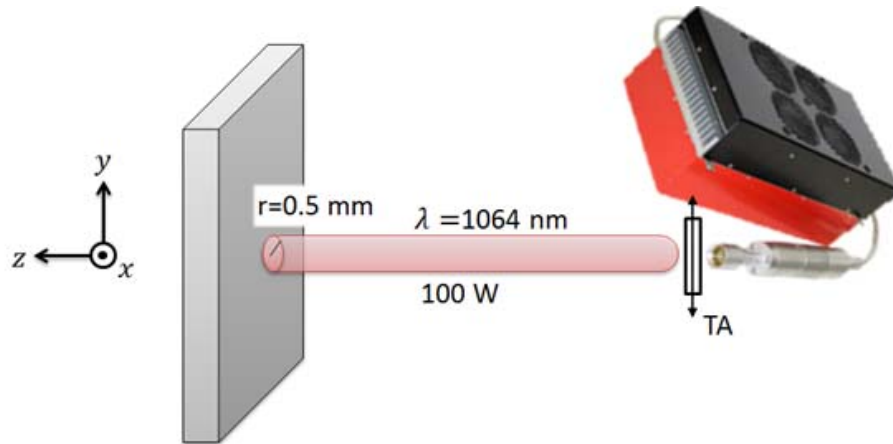

12. What is the frequency of the laser light?

- a.  $1.2 \times 10^{14}$  Hz
- b.  $2.8 \times 10^5$  Hz
- c.  $3.5 \times 10^{-15}$  Hz
- d.  $3.5 \times 10^{14}$  Hz
- e.  $2.8 \times 10^{14}$  Hz

13. The magnetic field of the laser light after the polarizer is along which direction?

- a. z
- b. y
- c. x

14. What is the intensity of the laser beam after the polarizer, assuming that the power is uniformly distributed across the beam?

- a.  $1.3 \times 10^8$  W/m<sup>2</sup>
- b.  $4.0 \times 10^8$  W/m<sup>2</sup>
- c.  $3.2 \times 10^7$  W/m<sup>2</sup>

*The next two questions continue from the previous page:*

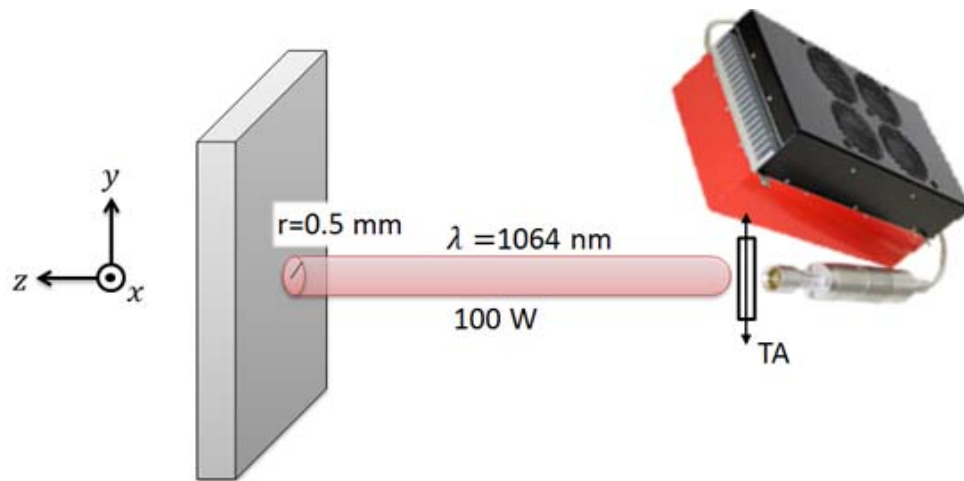

15. What is the rms electric field of the laser beam?

- a.  $2.2 \times 10^5 \text{ V/m}$
- b.  $5.2 \times 10^5 \text{ V/m}$
- c.  $3.8 \times 10^9 \text{ V/m}$
- d.  $2.2 \times 10^2 \text{ V/m}$
- e.  $4.8 \times 10^{10} \text{ V/m}$

16. The light directly emitted from the laser (before the polarizer) is unpolarized. How much power is emitted from the laser before the light hits the polarizer?

- a. 50 W
- b. 100 W
- c. 200 W

17. A laser beam travels from air into a dove prism as shown below. The dashed line is a normal to the surface at which the beam enters the prism. What is the index of refraction of the prism?

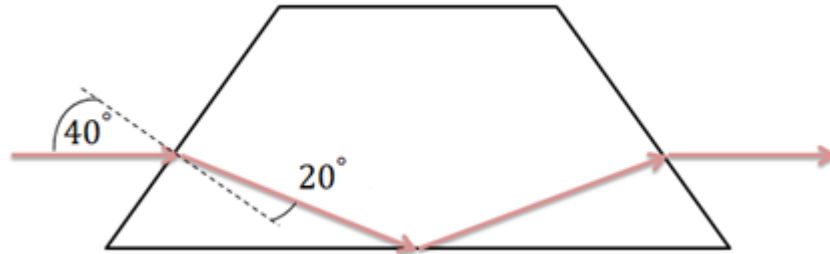

- a. 1.50
- b. 0.76
- c. 1.88
- d. 1.44
- e. 2.50

20. As shown below, vertically polarized light with intensity  $I_0$  is emitted from an LCD monitor. You take your polarized sunglasses and hold them between your eyes and the monitor. How much light intensity is transmitted through your sunglasses to your eyes if their transmission axis makes a  $35^\circ$  angle with the vertical direction?

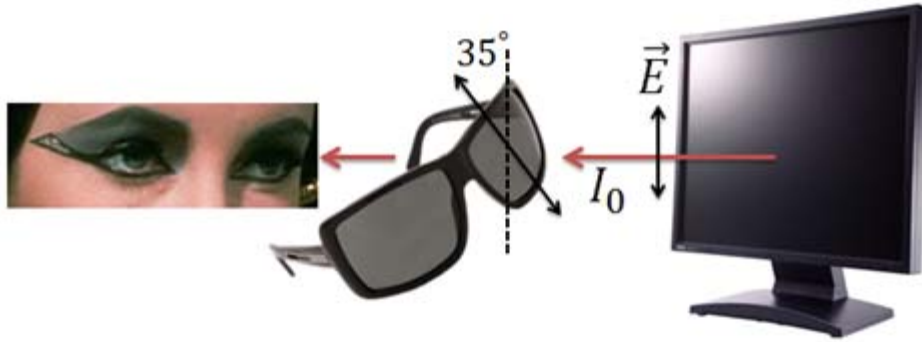

- a.  $0.23 I_0$
- b.  $0.82 I_0$
- c.  $0.75 I_0$
- d.  $1.12 I_0$
- e.  $0.67 I_0$

*The next two questions pertain to the following situation:*

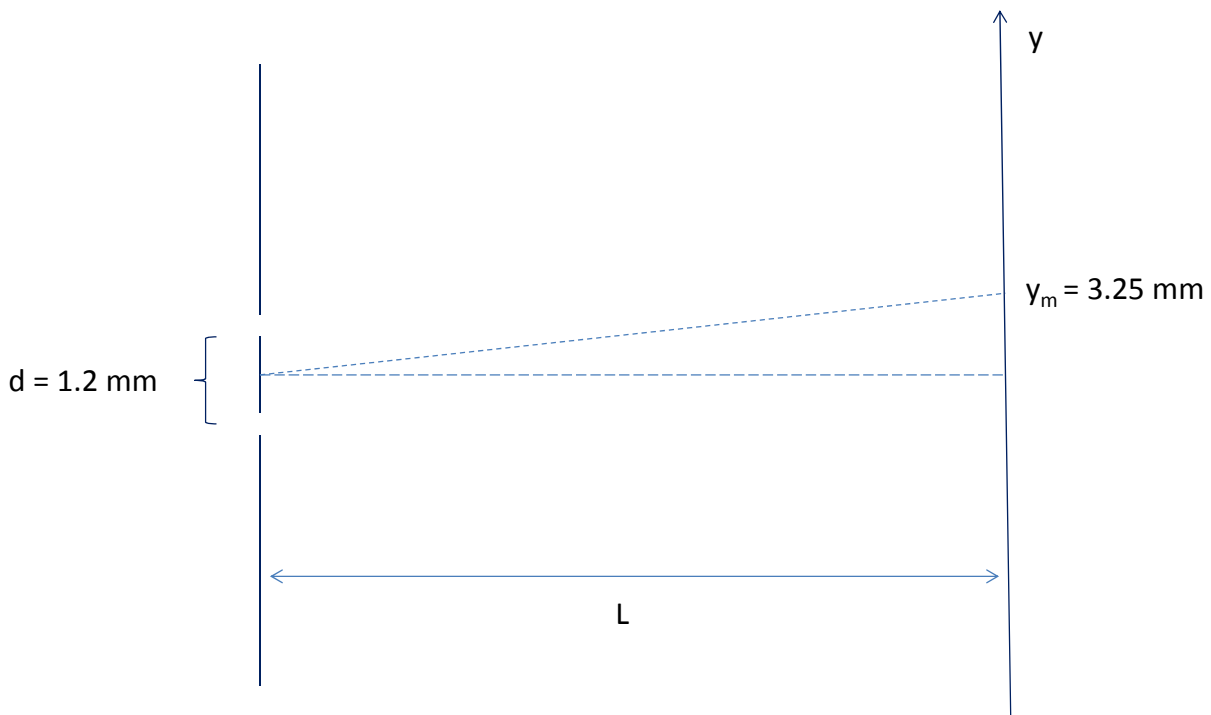

21. A double slit experiment has two slits separated by a distance  $d = 1.2 \text{ mm}$ . Monochromatic (single-wavelength) light is impinging on the two slits with an unknown wavelength. A screen a distance  $L = 2.5 \text{ m}$  away has a third interference maximum ( $m = 3$ ) at  $y = 3.25 \text{ mm}$ . What is the light's wavelength?

- a. 520 nm
- b. 102 nm
- c. 341 nm
- d. 189 nm
- e. 208 nm

*The next question continues from the previous page:*

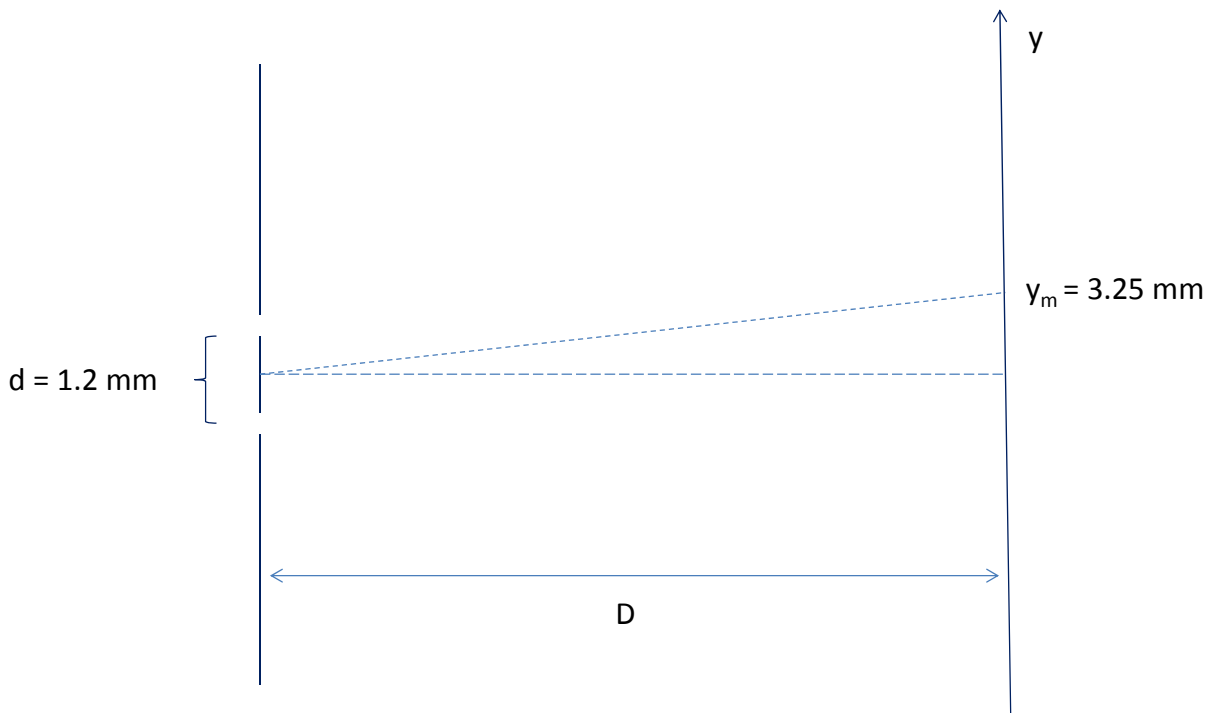

22. The screen is now moved to a new distance  $D$ . A different light source of wavelength  $50 \text{ nm}$  impinges on the two slits. A maximum of order  $m = 2$  now occurs at  $y = 3.25 \text{ mm}$ . What is the new distance  $D$  of the screen from the double slits?

- a.  $39.0 \text{ m}$
- b.  $0.9 \text{ m}$
- c.  $3.2 \text{ m}$

*The next two questions pertain to the following situation.*

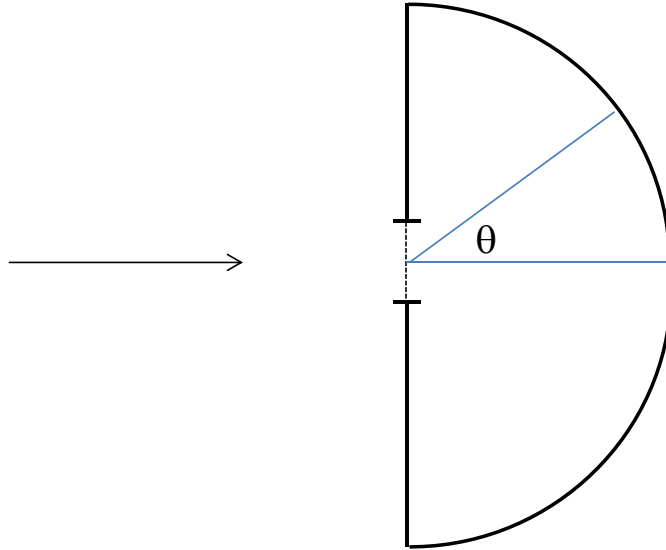

24. A diffraction grating spectrometer has a diffraction grating and a cylindrical screen. The diffraction grating has 8257 slits/cm. Light impinges on the diffraction grating. At which angle  $\theta$  is the 3<sup>rd</sup> order maximum for violet light ( $\lambda = 390 \text{ nm}$ ) ?

- a.  $\theta = 75^\circ$
- b.  $\theta = 41^\circ$
- c.  $\theta = 32^\circ$
- d.  $\theta = 23^\circ$
- e.  $\theta = 5^\circ$

25. The spectrometer is now immersed in a transparent fluid with index of refraction  $n = 1.2$ . What is the angle for the 2<sup>nd</sup> order maximum of the violet light ( $\lambda = 390 \text{ nm}$ ) ?

- a.  $\theta = 50^\circ$
- b.  $\theta = 23^\circ$
- c.  $\theta = 75^\circ$
- d.  $\theta = 5^\circ$
- e.  $\theta = 32^\circ$



The next two questions pertain to the following situation.

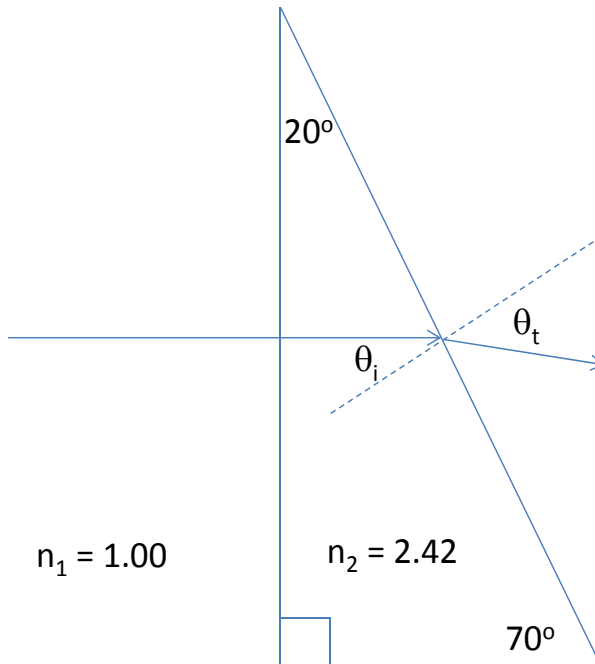

26. A ray of light impinges normally upon a right-angle prism as shown in the diagram above. The prism is made of diamond with an index of refraction  $n_2 = 2.42$ . What is the transmitted angle  $\theta_t$  with respect to the surface normal on the transmission side?

- a.  $\theta_t = 55.9^\circ$
- b.  $\theta_t = 12.1^\circ$
- c.  $\theta_t = 62.3^\circ$
- d.  $\theta_t = 34.2^\circ$
- e.  $\theta_t = 73.2^\circ$

27. What angle of incidence  $\theta_i$  relative to the surface normal on the transmission side would correspond to the critical angle for total internal reflection?

- a.  $\theta_t = 43.6^\circ$
- b.  $\theta_t = 24.4^\circ$
- c.  $\theta_t = 31.2^\circ$

**Check to make sure you bubbled in all your answers.  
Did you bubble in your name, exam version and network-ID?**

## KEY

1. a
2. ab
3. c
4. a
5. e
6. c
7. e
8. a
9. b
10. e
11. d
12. e
13. c
14. a
15. a
16. c
17. c
18. e
19. b
20. e
21. a
22. a
23. e
24. a
25. e
26. a
27. b

The following 3 questions refer to the following situation.

7. A conducting ring sits in an external magnetic field. Initially the magnetic field is zero. The field is varied with time according to the graph with a positive B field pointing into the page.

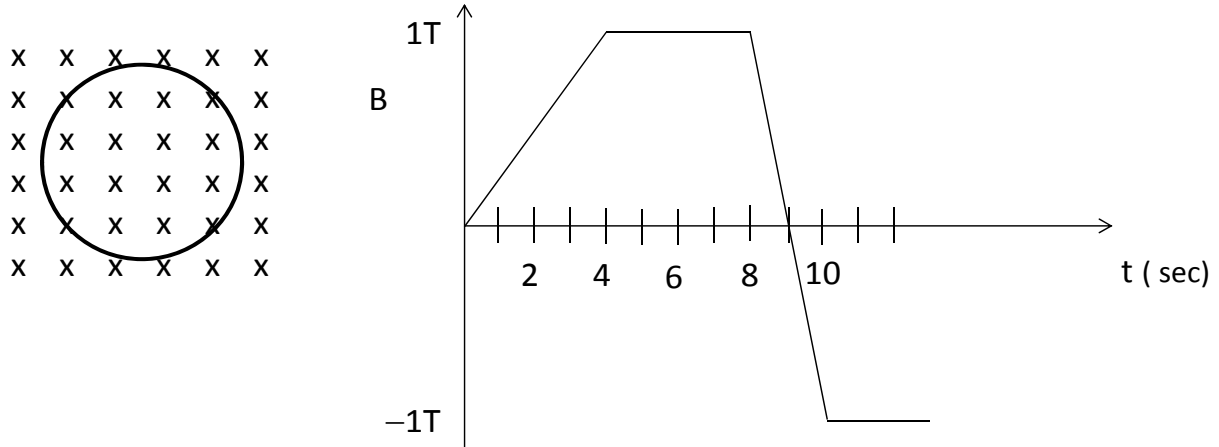

Which graph below best represents the EMF induced in the loop versus time?

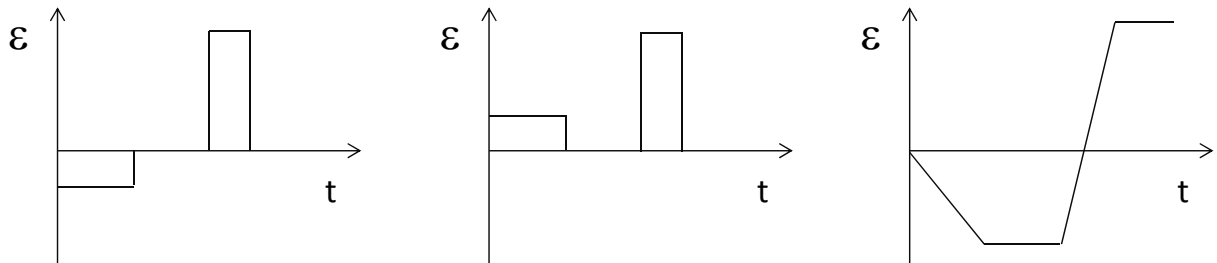

a

b

c

- a. a
- b. b
- c. c

The following 2 questions continue from the previous page.

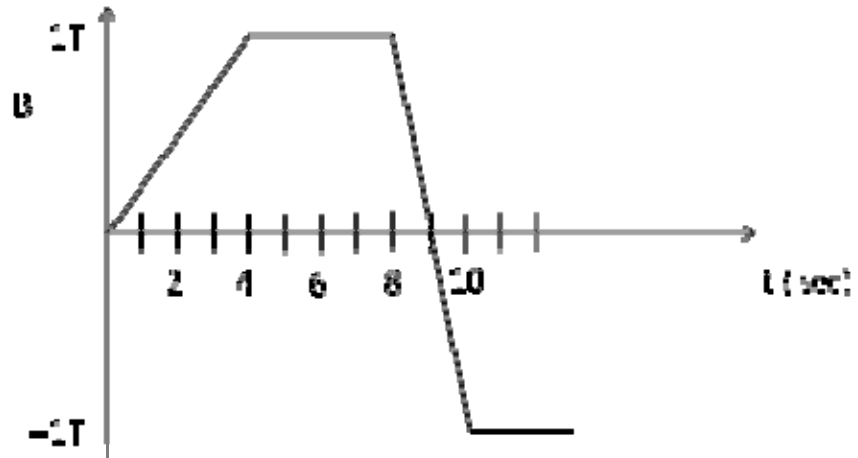
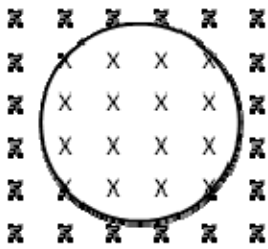

8. Relate the magnitude of the current in the loop at  $t=2$  seconds to the magnitude of the current in the loop at  $t=9$  seconds.

- $I(2 \text{ sec}) > I(9 \text{ sec})$
- $I(2 \text{ sec}) < I(9 \text{ sec})$
- $I(2 \text{ sec}) = I(9 \text{ sec})$

9. The current generated at  $t=2$  seconds and  $t=9$  seconds are

- in the same direction
- in opposite directions
- no current is generated at those times

26. A step-up transformer is used to supply adequate voltage to a neon sign.

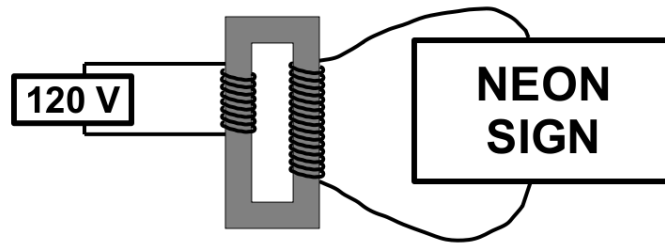

The transformer is designed to have an output voltage of 1200 V when the primary is connected to a 120 V source. How many turns must the secondary winding have if the number of primary turns is 50?

- a. 10 turns
- b. 50 turns
- c. 100 turns
- d. 500 turns
- e. 1000 turns

**Did you bubble in your name, exam version, and network ID?  
Check to make sure you have bubbled in all your answers.**

## KEY

## Fall 2011 – Exam 2

1. a
2. b
3. b
4. b
5. b
6. c
7. a
8. b
9. b
10. a
11. c
12. a
13. c
14. d
15. a
16. b
17. d
18. e
19. d
20. c
21. a
22. a
23. d
24. b
25. b
26. d

*The next three questions pertain to the following situation.*

A coil consisting of 5 square turns connected in series rotates at 60 revolutions per second ( $\omega = 2\pi 60$  radians per second). The magnetic field  $B = 2$  T points in the  $-z$  direction (into the page). At  $t = 0$ , the plane of the coil lies in the  $x$ - $y$  plane; a side of the coil is labeled with points "a" and "b." The rotation is around the  $y$  axis, such that at  $t=0$  side a-b is moving out of the page. The loops have an area of  $100 \text{ cm}^2$  and no resistance of their own. A  $10 \Omega$  resistor is connected across the coils as shown.

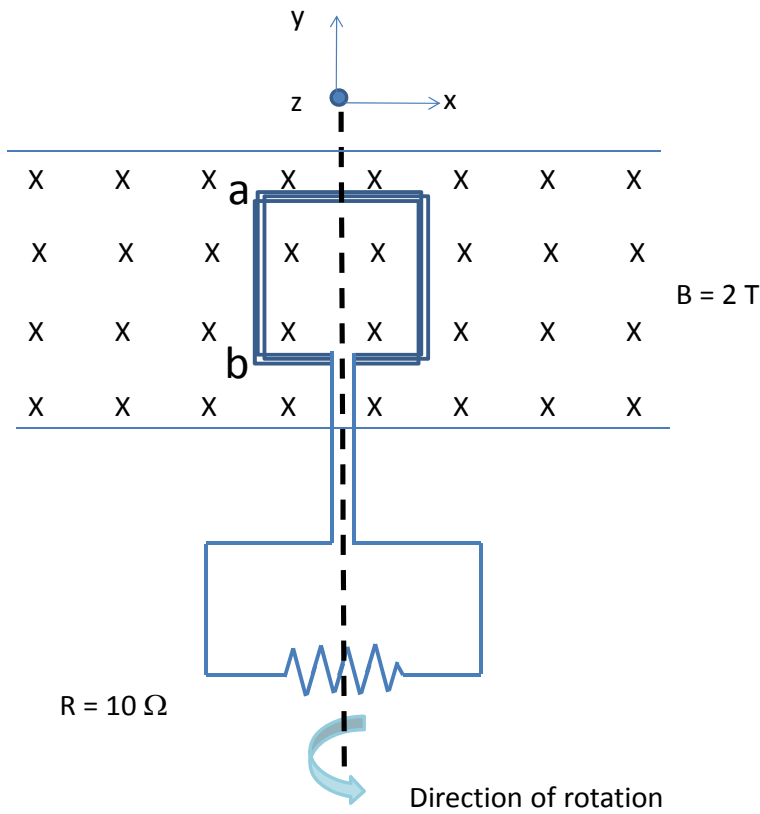

1. At  $t = 0$ 
  - a. the current flows clockwise, directly from point b to point a.
  - b. the current flows counterclockwise, directly from point a to point b.
  - c. the current is zero.
  
2. The maximum value of the current is
  - a. 0 A
  - b. 1.00 A
  - c. 2.56 A
  - d. 100.53 A
  - e. 3.77 A

The next question continues from the previous page.

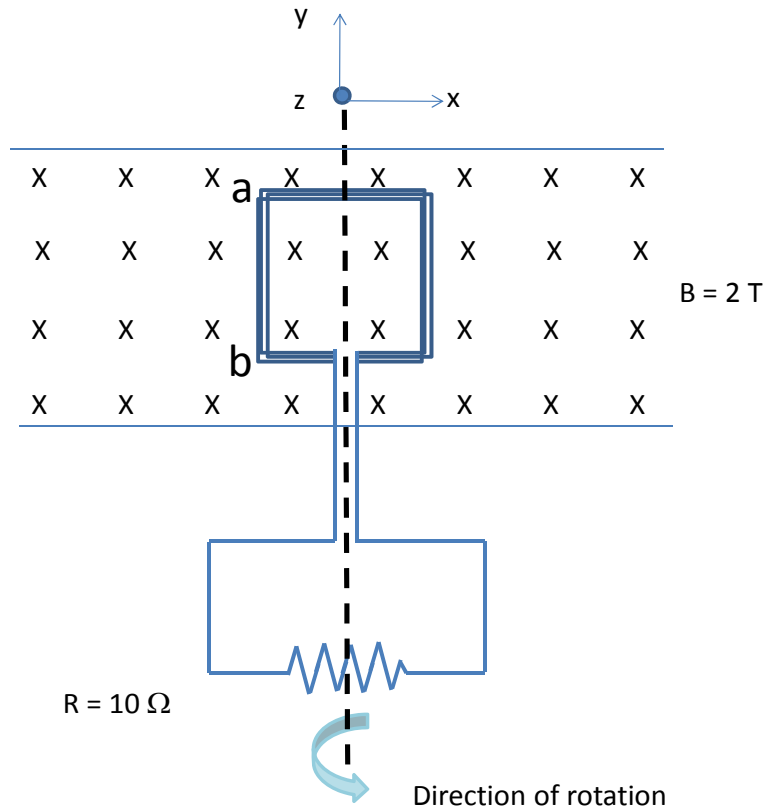

3. Once the coil has rotated forward by  $45^\circ$ 
  - a. the current flows clockwise, directly from point b to point a.
  - b. the current flows counterclockwise, directly from point a to point b.
  - c. the current is zero.



*The next two questions pertain to the following situation.*

A triangular conducting coil lies in a uniform magnetic field  $B$  which varies in time as shown in the graph of  $B$  (Tesla) versus  $t$  (seconds). At  $t = 1$  s, the magnetic field is pointing out of the page. The triangle has height  $h = \sqrt{3}$  m, and the base of the triangle has length  $L = 2$  m.

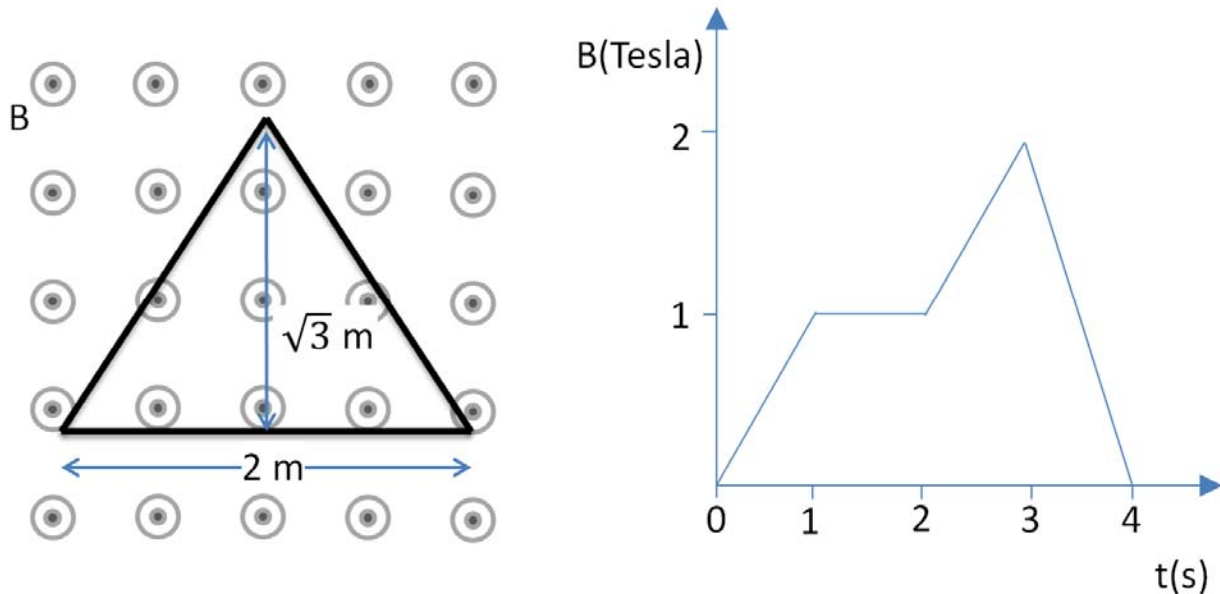

4. Which statement best represents the situation at  $t = 3.5$  s?
- The magnitude of the induced emf is 4.5 V, and the current flows counterclockwise.
  - The magnitude of the induced emf is 4.5 V, and the current flows clockwise.
  - The magnitude of the induced emf is 3.5 V, and the current flows counterclockwise.
  - The magnitude of the induced emf is 3.5 V, and the current flows clockwise.
  - There is no induced emf.
5. The current is zero
- between  $t = 1$  s and  $t = 2$  s.
  - at  $t = 0.5$  s.
  - at  $t = 3.5$  s.

*The next three questions pertain to the following situation.*

An electromagnetic wave indicated below has wavelength  $\lambda = 420$  nm.

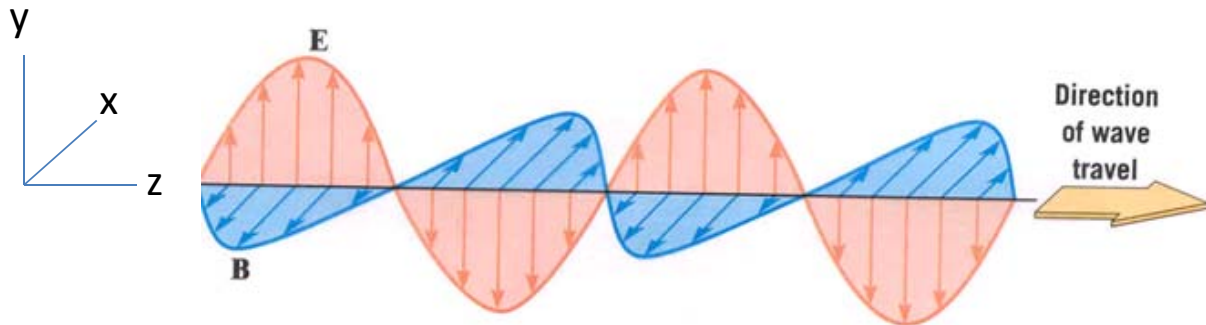

6. This wave is polarized along the
  - a. x axis.
  - b. y axis.
  - c. z axis.
  
7. The frequency of this wave is
  - a.  $7.14 \times 10^{14}$  Hz
  - b.  $2.13 \times 10^{14}$  Hz
  - c.  $4.76 \times 10^{14}$  Hz
  
8. The time it takes for a point on the wave to travel forward 2 m is
  - a. 2.30 ms
  - b. 6.67 ns
  - c. 1.75 ps

15. There is a transformer inside the charger for your cell phone that is designed to reduce the voltage supplied by an electrical outlet. The outlets in your house provide  $V_{\text{rms}}=120\text{ V}$  AC power, while the charger requires  $V_{\text{max}}=5\text{ V}$  AC power. How many turns should there be on the secondary side of the charger if there are 100 primary turns?

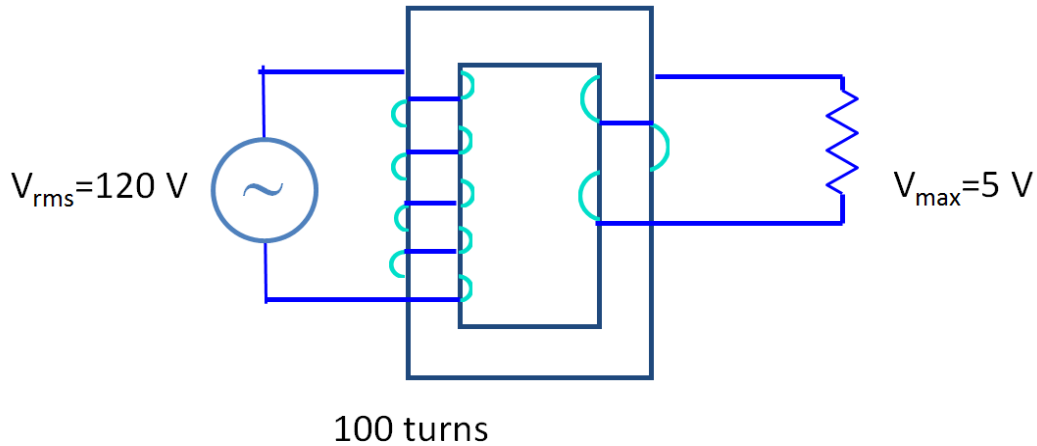

- a. 3
- b. 6
- c. 1700

## KEY

## Spring 2012 – Exam 2

1. c
2. e
3. a
4. c
5. a
6. b
7. a
8. b
9. c
10. c
11. e
12. a
13. d
14. c
15. a
16. c
17. e
18. e
19. b
20. b
21. a
22. b
23. a
24. e
25. b
26. a

***The following situation pertains to the next two questions:***

A transformer is used in the power supply for your computer to reduce the voltage supplied by a wall outlet. 120 V rms from the outlet is applied to the primary side of the transformer, and 20 V rms is produced on the secondary side of the transformer, which is connected to the computer. The rms current on the primary side of the transformer is 0.5 A.

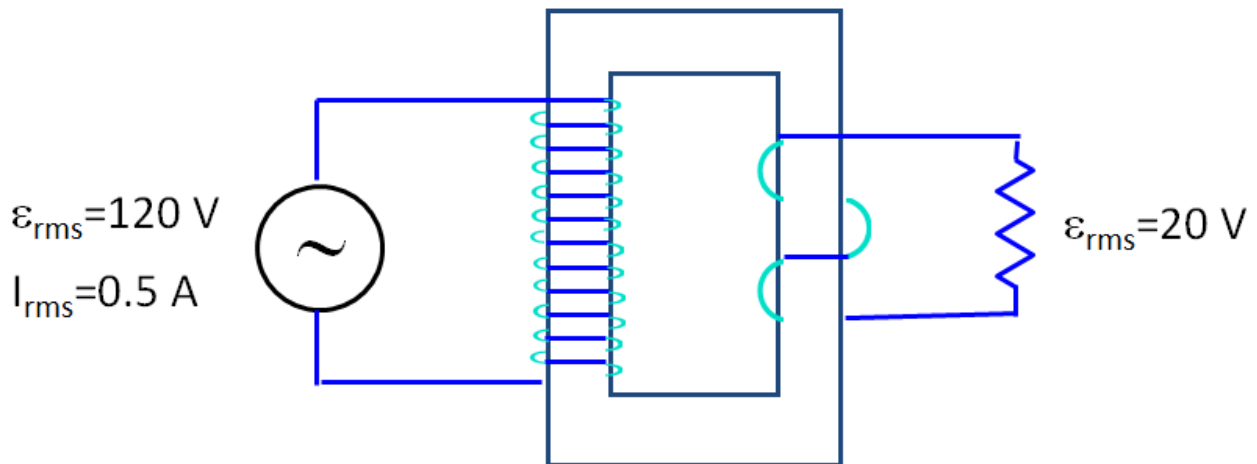

3. What is the rms current on the secondary side of the transformer?

- a. 0.08 A
- b. 3 A
- c. 0.5 A

4. How much power is supplied to the computer?

- a. 60 W
- b. 10 W
- c. 1.6 W

*The next two questions pertain to the following situation.*

Unpolarized light with intensity  $I_0$  is incident on a series of three polarizers, as shown in the picture below.

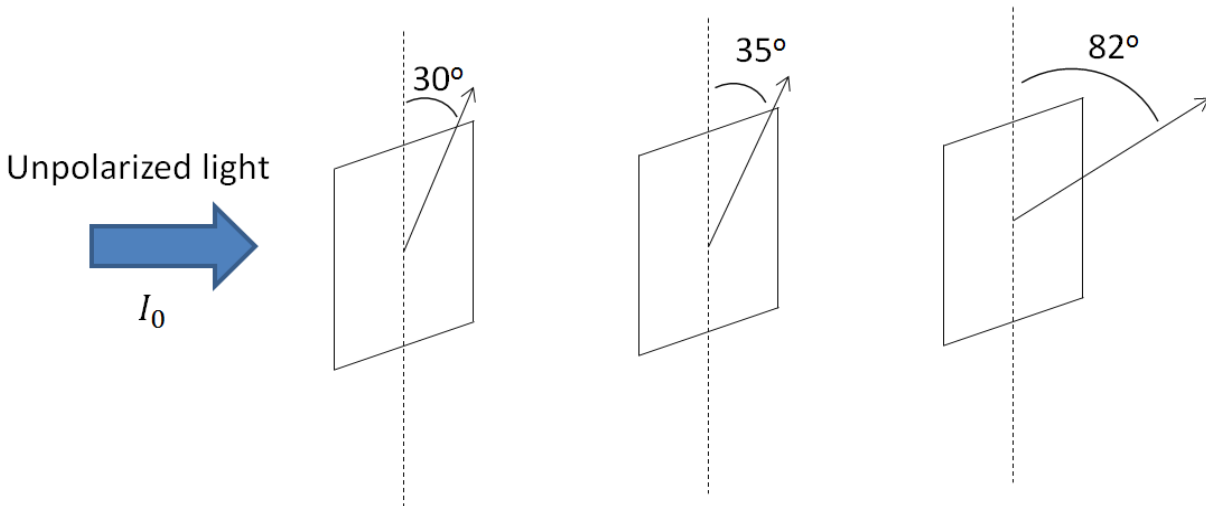

9. The intensity after the first polarizer is

- a.  $0.75 I_0$
- b.  $0.87 I_0$
- c. independent of the angle of the first polarizer.

10. The intensity of the light after the third polarizer is

- a.  $0.05 I_0$
- b.  $0.34 I_0$
- c.  $0.23 I_0$

*The following situation pertains to the next three questions:*

A generator coil rotates in a uniform and constant magnetic field of  $B = 1\text{ T}$ . The coil has 10 windings and the rotation frequency of the coil in the field is  $f = 0.5\text{ Hz}$  ( $\omega = 3.14\text{ rad/s}$ ). The resistance of all conductors in the circuit can be neglected. However, there is an external load resistor of  $R = 10\ \Omega$ . The coil rotates around the  $y$ -axis in the direction indicated by the circular arrow in the drawing below. Looking along the  $y$ -axis, the rotation is counterclockwise (i.e., the side **ab** of the wire loop moves into the page). The area of the coil is  $1\text{ m}^2$ .

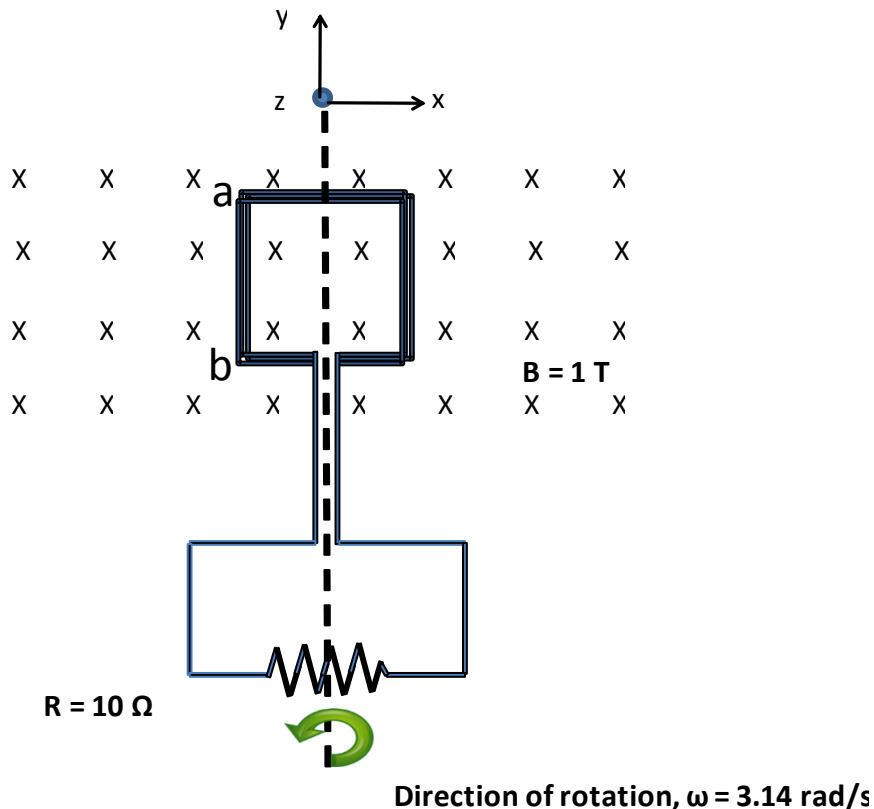

10. For the situation shown above, which statement is correct concerning the magnitude of the current?

- The current reaches its maximum value in the clockwise direction.
- The current reaches its maximum value in the counter-clockwise direction.
- The current is zero.

11. When the generator coil has rotated by an angle of 30 degrees starting from the situation shown above, what is the direction of the current?

- from a to b
- from b to a
- zero

12. What is the maximum current through the resistor?

- a. 3.14 A
- b. 2.67 A
- c. 1.33 A
- d. 1.0 A
- e. 0.1 A

*The following situation pertains to the next two questions:*

A metal frame with an internal resistance of  $1 \text{ m}\Omega$  enters a region of a uniform magnetic field  $B = 1 \text{ T}$ . The area of the frame is  $1 \text{ m}^2$ . The velocity of the frame,  $v$ , is constant. At  $t = 0$ , the upper edge of the frame reaches the boundary of the magnetic field. From this point of time it takes 10 seconds for the frame to fully enter the magnetic field. After 30 seconds of uniform motion the frame exits the magnetic field region again.

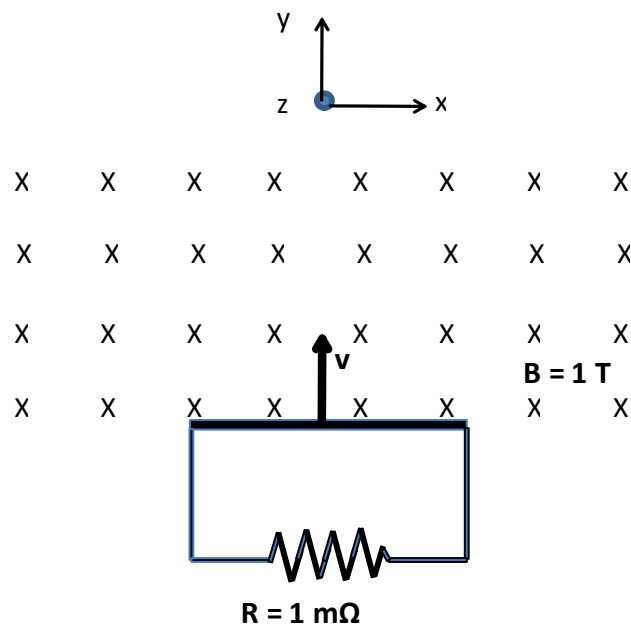

13. From Lenz's rule, what is the relation between the currents induced in the metal frame on entrance to and upon exit from the magnetic field?

- a. Entrance: clockwise                      Exit: clockwise
- b. Entrance: clockwise                      Exit: counterclockwise
- c. Entrance: counterclockwise              Exit: clockwise



14. What is the maximum magnitude of the induced current?

- a. 1000.0 A
- b. 100.0 A
- c. 10.0 A
- d. 1.0 A
- e. 0.1 A

***The following situation pertains to the next three questions:***

Electromagnetic waves emitted from a cellular phone propagate in the x-direction as shown in the figure below. The frequency of the wave is  $f=900$  MHz.

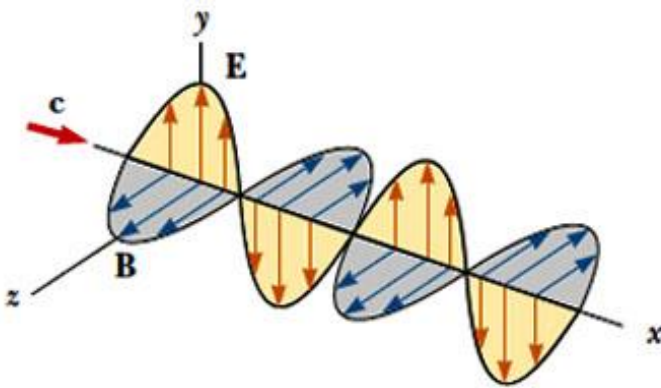

15. How long does it take for the wave to travel from the cell phone to a cell tower 5 km away?

- a. 13.3  $\mu\text{s}$
- b. 16.7  $\mu\text{s}$
- c. 13.3 ns
- d. 16.7 ns
- e. 1.33 ms

16. What is the wavelength of the electromagnetic wave?

- a. 3.00  $\mu\text{m}$
- b. 0.33 mm
- c. 33.3 cm

17. The polarization of the wave is in the

- a. x-direction.
- b. y-direction.
- c. z-direction.

18. The International Space Station (ISS) is powered by 8 wings of solar cell arrays. Each array has an area of  $375 \text{ m}^2$ . The solar cells turn 6% of the energy of the sunlight into electric energy. If the rms magnitude of the electric field of the sun light incident on the solar cell arrays is  $715 \text{ V/m}$ , how much electrical power do the 8 wings of solar cell arrays provide to the ISS ?

- a. 300 kW
- b. 144 kW
- c. 244 kW
- d. 18 kW
- e. 30 kW

## KEY

## Exam 2 – Fall 2012

1. c
2. a
3. b
4. a
5. e
6. b
7. e
8. b
9. d
10. c
11. b
12. a
13. c
14. b
15. b
16. c
17. b
18. c
19. b
20. e
21. b
22. c
23. b
24. c
25. b
26. a
27. a

**The next three questions pertain to the following situation:**

A single circular loop of wire of radius  $r_{loop} = 5$  cm is placed around a very long solenoid as shown in the figure. The solenoid has a radius  $r_{sol} = 1$  cm, a length  $L = 40$  cm, 10000 turns of wire, and is driven by a current  $I = 0.2$  A.

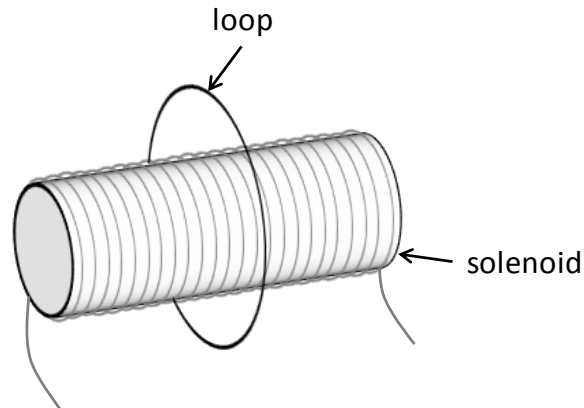

4. Calculate the flux  $\Phi$  through the loop.

- a.  $\Phi = 1.2 \times 10^{-7}$  Wb
- b.  $\Phi = 2.0 \times 10^{-6}$  Wb
- c.  $\Phi = 6.7 \times 10^{-6}$  Wb
- d.  $\Phi = 5.5 \times 10^{-5}$  Wb
- e.  $\Phi = 9.5 \times 10^{-5}$  Wb

5. Which of the following will NOT change the flux  $\Phi$  through the loop?

- a. decreasing the current  $I$  in the solenoid
- b. increasing the radius  $r_{loop}$  of the loop
- c. tilting the loop relative to the solenoid

6. Calculate the energy  $U$  stored in the solenoid.

- a.  $U = 2.0$  mJ
- b.  $U = 0.37$  mJ
- c.  $U = 12.8$  mJ

*The next two questions pertain to the following situation:*

A loop of wire of area  $A = 0.01 \text{ m}^2$  lies in the plane of the page. The loop sits in a spatially uniform magnetic field  $B$ , which varies with time according to the graph below. A positive  $B$  corresponds to a magnetic field pointing out of the page; a negative  $B$  corresponds to a field pointing into the page.

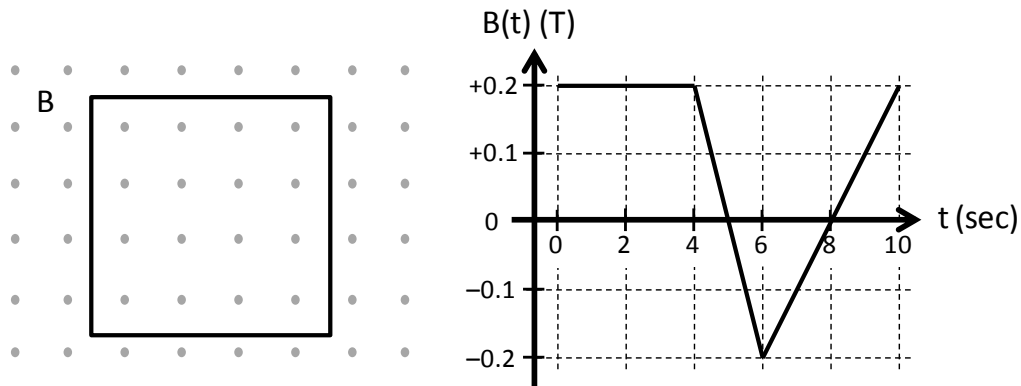

8. At which of the following times is the induced emf  $\varepsilon$  in the loop maximum?

- a.  $t = 2 \text{ s}$
- b.  $t = 5 \text{ s}$
- c.  $t = 7 \text{ s}$

9. Calculate the magnitude of the induced emf  $\varepsilon$  in the loop at time  $t = 8 \text{ s}$ .

- a.  $\varepsilon = 0 \text{ mV}$
- b.  $\varepsilon = 1.0 \text{ mV}$
- c.  $\varepsilon = 6.67 \text{ mV}$
- d.  $\varepsilon = 37.5 \text{ mV}$
- e.  $\varepsilon = 62.5 \text{ mV}$

*The next three questions pertain to the following situation:*

A metal bar slides on a conducting track with width  $L = 5 \text{ cm}$  and a resistor  $R = 2 \ \Omega$  in a uniform magnetic field  $B = 0.1 \text{ T}$  out of the page. The bar is pulled to the right with a force  $F_{pull} = 2 \times 10^{-5} \text{ N}$ , such that the bar slides in that direction at a **constant speed**  $v$ .

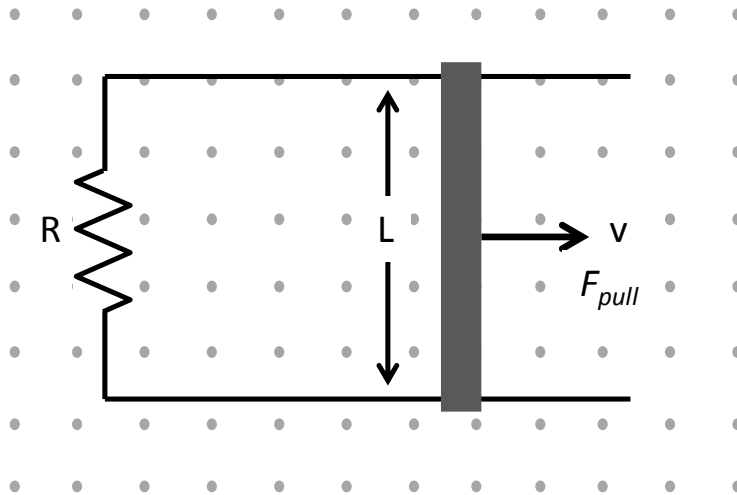

15. Calculate the magnitude of the current  $I$  in the sliding bar.

- $I = 4 \text{ mA}$
- $I = 1.5 \text{ mA}$
- $I = 0.25 \text{ mA}$
- $I = 17.5 \text{ mA}$
- $I = 0 \text{ mA}$

16. What is the correct expression for the speed  $v$  of the sliding bar?

- $v = \frac{LB}{F_{pull}R}$
- $v = \frac{F_{pull}R}{LB}$
- $v = \frac{F_{pull}R}{(LB)^2}$

17. A rectangular loop in a generator rotates at a constant angular frequency in uniform magnetic field as shown below. The bottom panel shows cross sectional views of the loop at three different moments. In which configuration is the magnitude of the induced current largest?

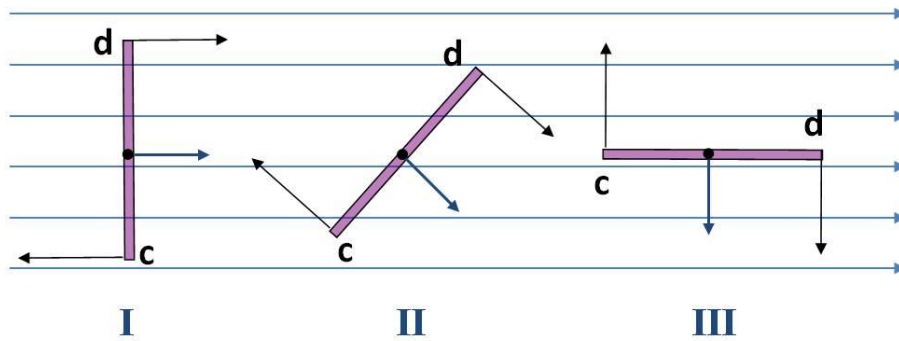
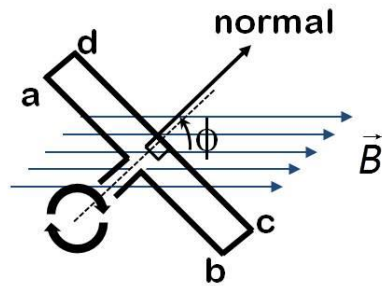

- a. I
- b. II
- c. III

*The next two questions pertain to the following situation:*

Consider a circuit consisting of *two* vertical metal bars labeled 1 and 2 that slide on two horizontal conducting rails, as shown in the figure. There is a uniform magnetic field  $B$  directed into the page *over the right half of the circuit only*. (There is NO magnetic field over the left half.)

Initially both sliding bars 1 and 2 are at rest.

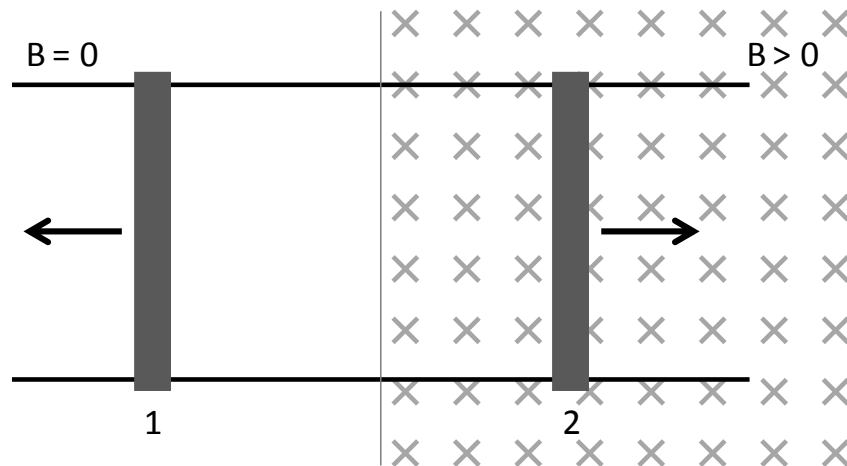

21. The sliding bar 2 is now moved to the right. In what direction does the current flow around the circuit?

- a. clockwise
- b. counterclockwise
- c. there is no current

22. Now sliding bar 2 is at rest and sliding bar 1 is moved to the left. In what direction does the current flow around the circuit?

- a. clockwise
- b. counterclockwise
- c. there is no current



*The next three questions pertain to the following situation.*

A transformer consists of a primary coil of  $N_p = 150$  turns and a secondary coil of unknown turns  $N_s$  as shown. The generator voltage is given as  $\varepsilon = 120\sin(120\pi t)$  Volts. The secondary coil is connected to a load of resistance  $R = 13 \Omega$ .

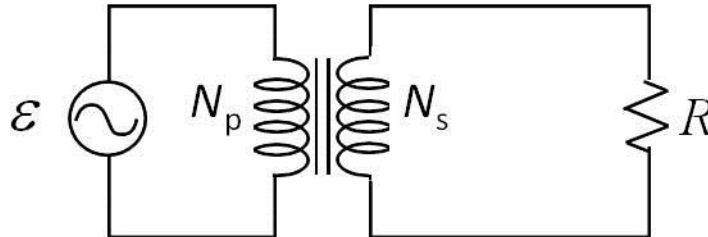

23. Find  $N_s$  for which the maximum induced voltage in the secondary coil is 20 V.

- a.  $N_s = 900$
- b.  $N_s = 60$
- c.  $N_s = 25$

25. If the generator is replaced with a 24 V battery, what is the maximum voltage,  $V_{\max}$ , across the secondary coil of 300 turns?

- a.  $V_{\max} = 0 \text{ V}$
- b.  $V_{\max} = 12 \text{ V}$
- c.  $V_{\max} = 48 \text{ V}$

## KEY

## Exam 2 – Spring 2013

1. b
2. b
3. c
4. b
5. bc
6. a
7. d
8. b
9. b
10. a
11. c
12. a
13. b
14. c
15. a
16. c
17. c
18. a
19. b
20. b
21. b
22. c
23. c
24. b
25. a
26. a

The next two questions pertain to the situation described below.

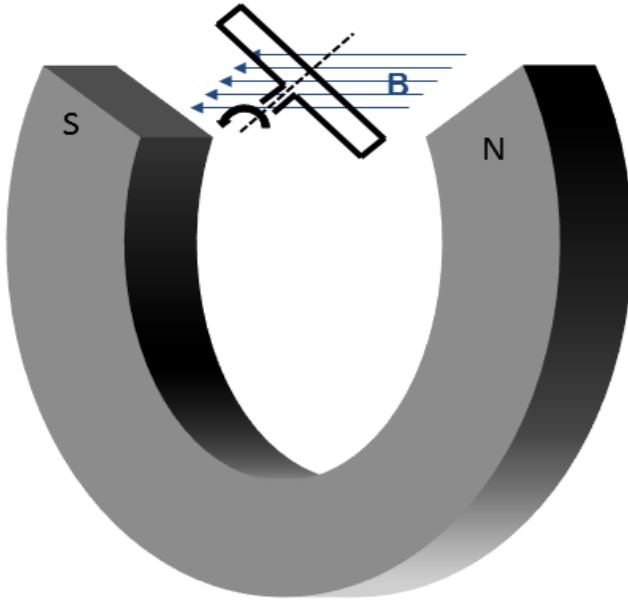

A coil of wire turns between the poles of a permanent magnet as shown in the diagram. The coil has  $N=34$  turns of wire. The magnet produces a constant field of magnitude  $B = 0.119 \text{ T}$ . The coil has a cross-sectional area  $A = 0.0411 \text{ m}^2$ .

8) The coil is driven at an angular frequency  $\omega = 4.08 \text{ rad/s}$ . What is the peak *emf*,  $\varepsilon$ , this generator can produce?

Just write down correct formula, then show inserted numbers and final result.

- a.  $\varepsilon = 0.02 \text{ V}$
- b.  $\varepsilon = 5.7 \text{ V}$
- c.  $\varepsilon = 16.5 \text{ V}$
- d.  $\varepsilon = 0.678 \text{ V}$
- e.  $\varepsilon = 0.166 \text{ V}$

9) If the coil is driven in the counter-clockwise direction, in what direction is the induced field at the instant shown?

Explain using flux and Lenz' law.

- a. *The induced field is directed toward the left.*
- b. *The induced field is directed toward the right.*
- c. *There is no induced field.*

The next three questions pertain to the situation described below.

The electric field for a plane electromagnetic wave in vacuum is given by

$$\mathbf{E} = 2100(\text{N/C}) \sin(-0.6 \text{ m}^{-1} z + \omega t) \hat{x}.$$

17) What is the frequency of the wave? Show equations used and values inserted.

a.  $f = 6 \times 10^5 \text{ Hz}$

b.  $f = 1.8 \times 10^8 \text{ Hz}$

c.  $f = 2.86 \times 10^7 \text{ Hz}$

$$k = 2 \pi / \text{wavelength (from lecture)}$$

$$\text{wavelength} = 2 \pi / k$$

$$= 2 \pi / 0.6$$

$$f = c / \text{wavelength}$$

$$= c * 0.6 / (2 \pi)$$

$$= 2.86e7$$

18) What is the magnitude of the magnetic field oscillation?

Show equation used and values inserted

a.  $B = 1.4 \times 10^5 \text{ T}$

b.  $B = 7 \times 10^{-6} \text{ T}$

c.  $B = 2100 \text{ T}$

$$E = cB$$

$$B = E/c$$

$$= 2100 / 3e8$$

$$= 7e-6$$

19) In what direction does the wave propagate?

Describe what information in equation tells the direction.

a. +x

b. -z

c. +z

The direction can be determined by looking at the argument of the sine function. Since it depends on the value of  $z$ , it must be moving in the  $+z$  direction. Since there is a relative minus sign between the two terms, it moves in the  $+z$  direction.

The next two questions pertain to the situation described below.

A beam of unpolarized light of intensity  $I_0$  travels in the positive  $z$ -direction and is incident from the left on a series of two linear polarizers as shown. The transmission axis of the two polarizers make angles of  $\theta_1 = 54$  degrees and  $\theta_2 = 122$  degrees, respectively, with respect to the positive  $x$ -axis. The intensity of the beam immediately after the first polarizer is  $I_1 = 214 \text{ W/m}^2$ .

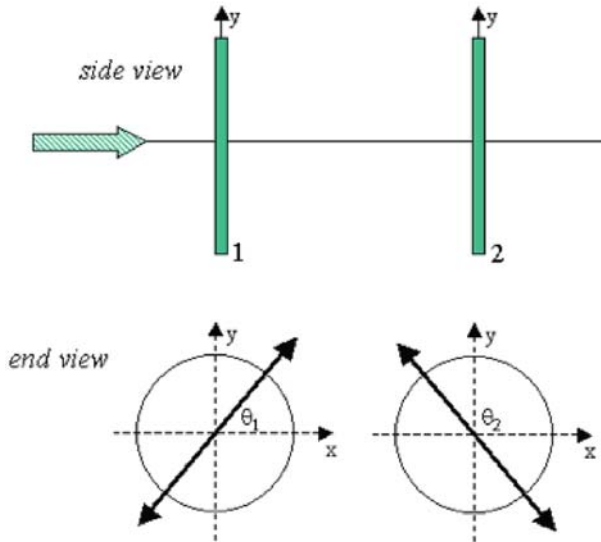

20) What is the intensity of the incident beam?

Show equation, and explain reason

- a.  $I_0 = 619 \text{ W / m}^2$
- b.  $I_0 = 428 \text{ W / m}^2$
- c.  $I_0 = 74 \text{ W / m}^2$

21) What is the intensity of the beam immediately after the second polarizer?

Show equation and explain reason

- a.  $I_2 = 30.1 \text{ W / m}^2$
- b.  $I_2 = 59.9 \text{ W / m}^2$
- c.  $I_2 = 74 \text{ W / m}^2$

The next four questions pertain to the situation described below.

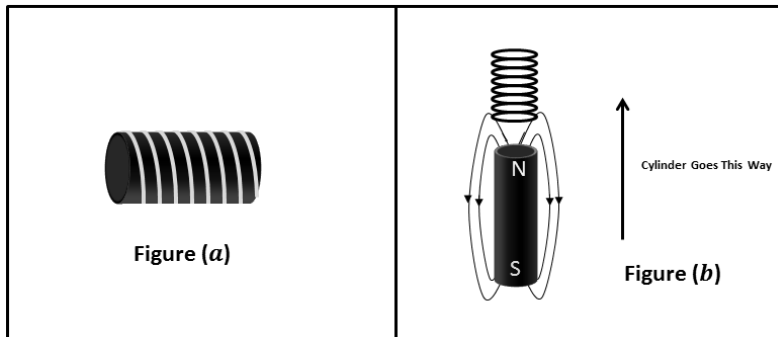

22) In figure (a) above, a coil is produced by wrapping a copper wire around a cylinder of iron. The iron cylinder is fixed within the wire. Which of the following statements is true: Briefly explain reason (2 sentences)

- a. *Neither of these.*
- b. *The iron will behave like a magnet if current flows through the wire.*
- c. *The wire will have an induced current if the iron is magnetized.*

23) In figure (b) above, a magnetic iron cylinder moves through the coil in the direction shown. Which of the following statements is true: Explain using flux and Lens's law

- a. *The induced current flows right to left across the front of the coil.*
- b. *The induced current flows left to right across the front of the coil.*
- c. *There is no induced current.*

24) In figure (b) the cylinder moves through the coil for  $t = 3.95 \text{ s}$  and produces  $|\mathcal{E}| = 0.119 \text{ V}$ . What is the magnitude of the change flux? Show equation, and values used for variables.

- a.  $\Delta \Phi = 0.94 \text{ T m}^2$
- b.  $\Delta \Phi = 0.235 \text{ T m}^2$
- c.  $\Delta \Phi = 0.0301 \text{ T m}^2$
- d.  $\Delta \Phi = 0.47 \text{ T m}^2$
- e.  $\Delta \Phi = 0.157 \text{ T m}^2$

25) In figure (b) the coil has a diameter  $d = 0.0411 \text{ m}$  and 100 turns of wire. The resistance per unit length is  $34.3 \Omega/\text{m}$ . The *emf* is  $|\mathcal{E}| = 0.119 \text{ V}$ . What is the magnitude current in the coil?

Show equations used, and values input to get answer.

- a.  $I = 269 \mu\text{A}$
- b.  $I = 844 \mu\text{A}$
- c.  $I = 53.7 \mu\text{A}$
- d.  $I = 3470 \mu\text{A}$
- e.  $I = 537 \mu\text{A}$

Physics 102 Exam 2 --  
Spring 2014

1. a
2. e
3. c
4. c
5. a
6. e
7. c
8. d
9. a
10. b
11. c
12. b
13. b
14. a
15. b
16. a
17. c
18. b
19. c
20. b
21. a
22. b
23. a
24. d
25. a