

10) In the following RC circuit with a switch S , two resistors R_1 and R_2 have the same resistance $R = 20 \Omega$, C denotes a capacitor of capacitance $15 \mu F$, and E denotes a 12 V battery.

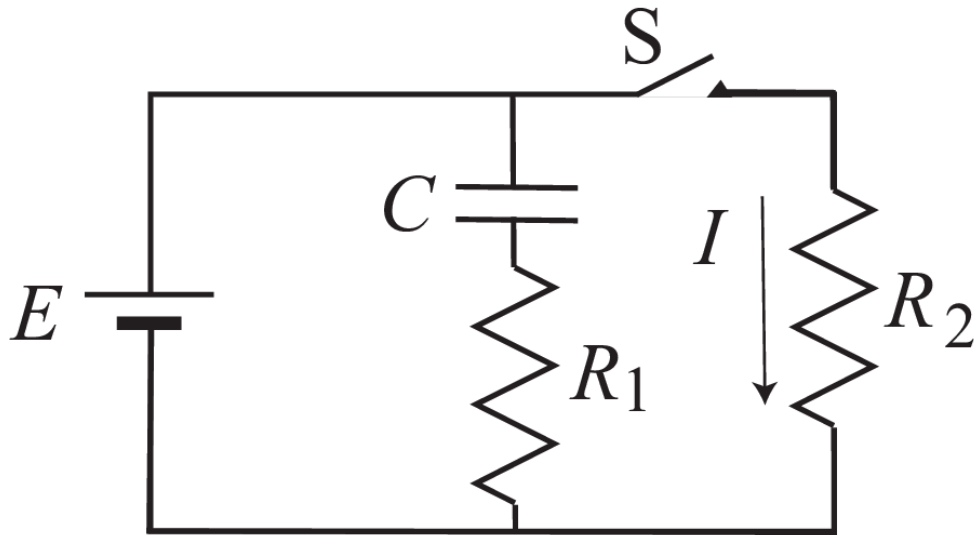

Initially, switch S is open for a long time. After $t = 0$ switch S is closed. Choose the best figure from below describing the time-dependence of the current I through R_2 . Do not forget that the battery E is still connected.

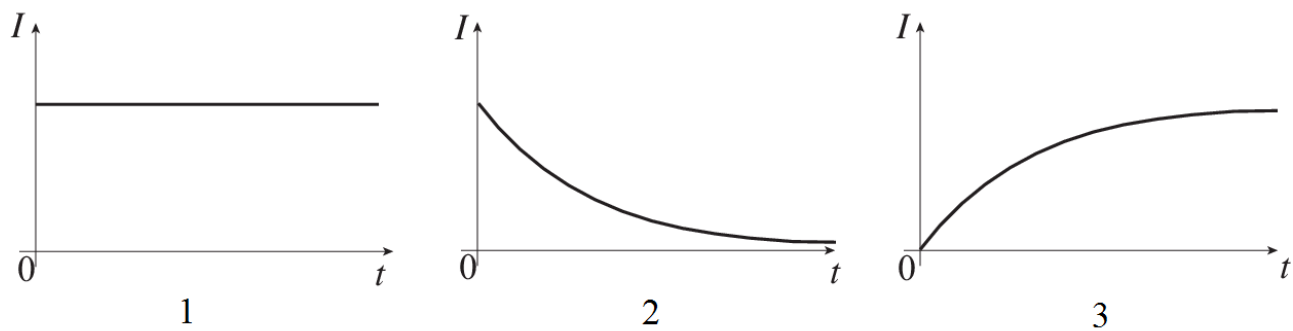

- a. 3
- b. 2
- c. 1

The next two questions pertain to the situation described below.

In the following RC circuit with a switch S , two resistors R_1 and R_2 have the same resistance $R = 29 \Omega$, C denotes a capacitor of capacitance $7 \mu F$, and E denotes a 12 V battery.

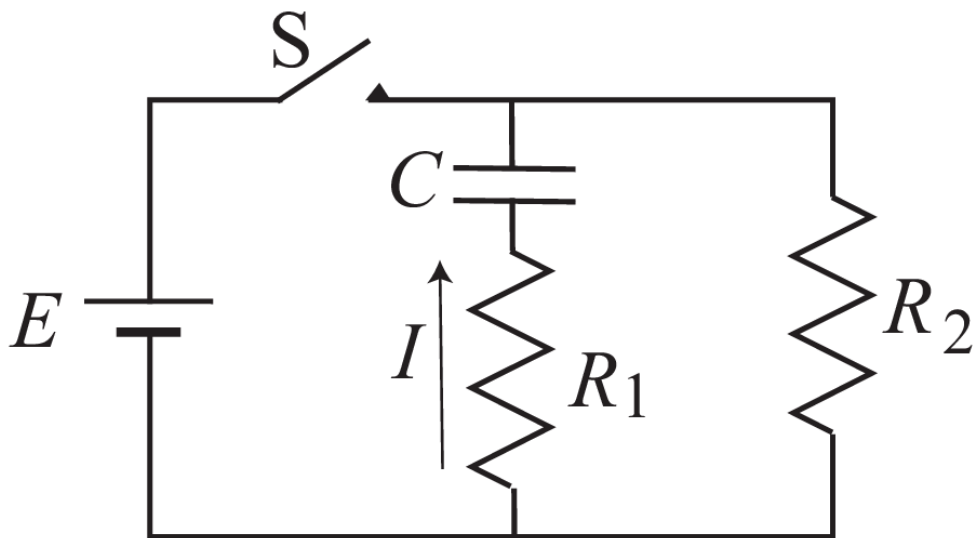

11) Switch S has been closed for a long time. What is the current I through R_1 immediately after S is opened? Pay attention to the direction of the current arrow in the figure.

- a. $I = +0.41 A$
- b. $I = -0.21 A$
- c. $I = +0.21 A$
- d. $I = 0 A$
- e. $I = -0.41 A$

12) What is the voltage V_2 across resistor R_2 at a time of 0.5 ms after switch S is opened?

- a. $V_2 = 3.2 V$
- b. $V_2 = 0.51 V$
- c. $V_2 = 1.8 V$

The next two questions pertain to the situation described below.

In the following figure, $E_1 = 12\text{ V}$, $E_2 = 4\text{ V}$, $R_1 = 7\ \Omega$, $R_2 = 12\ \Omega$, and $R_3 = 4\ \Omega$. Initially, the switch S is open.

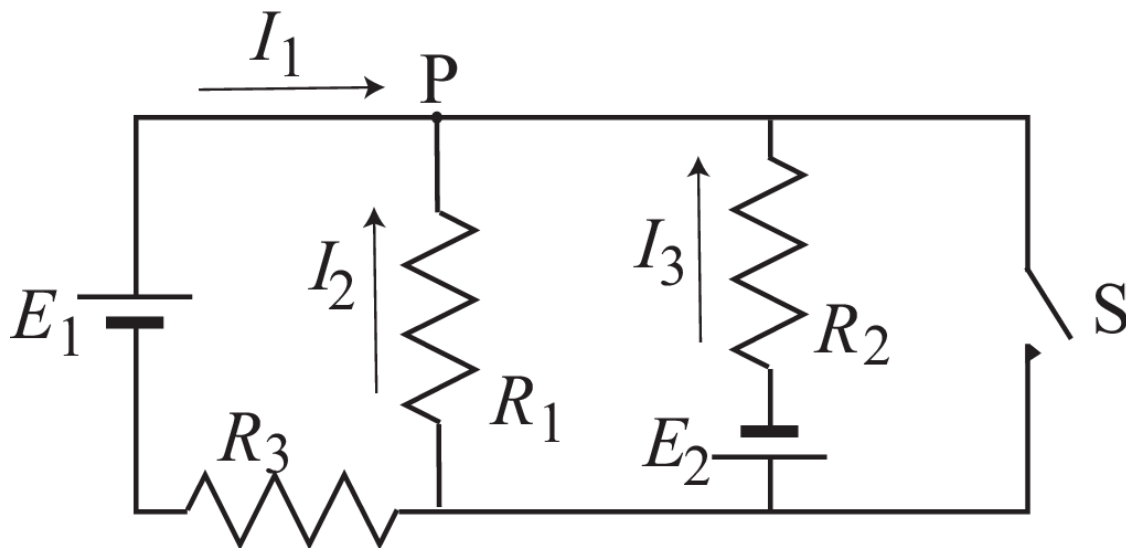

13) At junction P three currents I_1 , I_2 , and I_3 meet. Choose the correct relation among them from below.

- a. $I_1 + I_2 + I_3 = 0$
- b. $I_1 - I_2 - I_3 = 0$
- c. $-I_1 + I_2 - I_3 = 0$
- d. $I_1 - I_2 + I_3 = 0$
- e. $I_1 + I_2 - I_3 = 0$

14) When the switch S is closed, what is the current I_3 ?

- a. $I_3 = 0\text{ A}$
- b. $I_3 = -0.57\text{ A}$
- c. $I_3 = -0.75\text{ A}$
- d. $I_3 = -0.33\text{ A}$
- e. $I_3 = -0.7\text{ A}$

The next three questions pertain to the situation described below.

In the following figure, $E_1 = 12\text{ V}$,
 $E_3 = 7\text{ V}$, $R_1 = R_2 = R_3 = R_4 = 3\ \Omega$. E_2
 is not known.

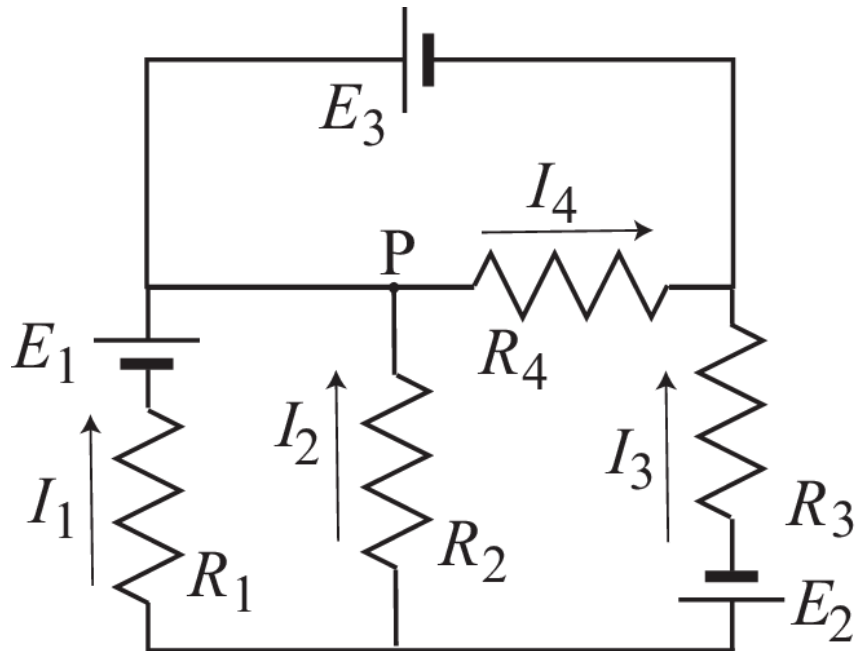

15) Choose the correct formula exhibiting Kirchhoff's loop law from the following formulas.

- a. $I_2R_2 + I_4R_4 - I_3R_3 - E_2 = 0$
- b. $I_2R_2 - I_4R_4 - I_3R_3 + E_2 = 0$
- c. $I_2R_2 + I_4R_4 - I_3R_3 + E_2 = 0$
- d. $I_2R_2 + I_4R_4 + I_3R_3 - E_2 = 0$
- e. $I_2R_2 + I_4R_4 + I_3R_3 + E_2 = 0$

16) What is the current I_4 ? Pay attention to the direction of the current arrow in the figure.

- a. $I_4 = 0\text{ A}$
- b. $I_4 = +1.2\text{ A}$
- c. $I_4 = -2.3\text{ A}$
- d. $I_4 = +2.3\text{ A}$
- e. $I_4 = -1.2\text{ A}$

17) The current I_2 is measured to be -1.5 A . What is the current I_1 ? Again, pay attention to the direction of the current arrow in the figure.

- a. $I_1 = +2.5\text{ A}$
- b. $I_1 = -2.5\text{ A}$
- c. $I_1 = -5.5\text{ A}$
- d. $I_1 = +5.5\text{ A}$
- e. $I_1 = 0\text{ A}$

The next two questions pertain to the situation described below.

A current carrying loop of radius $r = 14 \text{ cm}$ is oriented horizontally, with its area parallel to the x - z -plane in the figure below, and a uniform magnetic field is applied that has no z -component. The x -component of the B field is 3 T and its y -component is 4 T . The current $I = 7 \text{ A}$ is flowing into the $(-z)$ direction at the rightmost point of the loop, as denoted in the figure that shows a side view of the loop. (The $(-z)$ -direction points into the page).

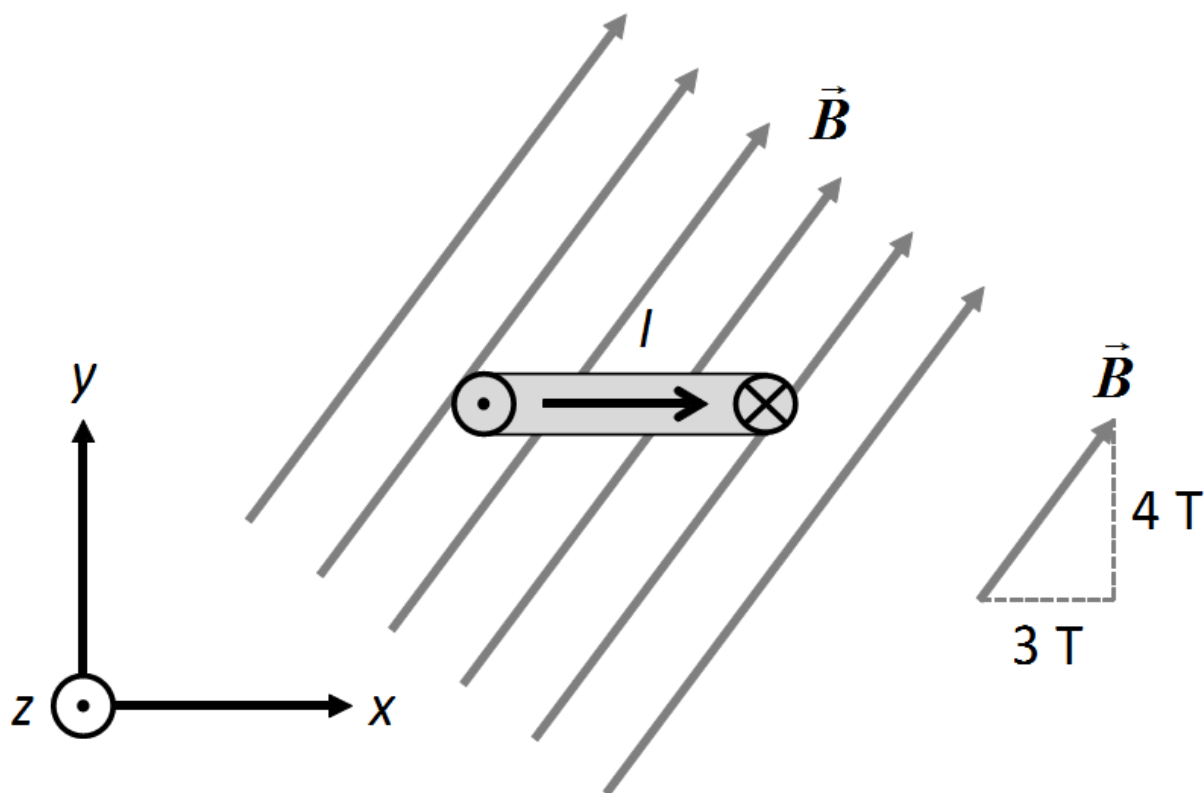

18) What is the magnitude of the torque on the current loop?

- a. $\tau = 1.7 \text{ N}\cdot\text{m}$
- b. $\tau = 2500 \text{ N}\cdot\text{m}$
- c. $\tau = 2.2 \text{ N}\cdot\text{m}$
- d. $\tau = 1.3 \text{ N}\cdot\text{m}$
- e. $\tau = 1800 \text{ N}\cdot\text{m}$

19) In which direction will the loop *start to turn* if left free?

- a. Clockwise about an axis parallel to the z -axis
- b. Counter-clockwise about an axis parallel to the z -axis
- c. Around an axis that is *not* parallel to the z axis.

20) Four long straight wires carrying currents of equal magnitude ($I_1 = I_2 = I_3 = I_4 = I$) are parallel or antiparallel to each other such that their cross sections form the corners of a square, as shown in the figures. The figures indicate the directions of the current in each wire. In which case is the magnitude of the total magnetic field at the center of the square (O) the largest?

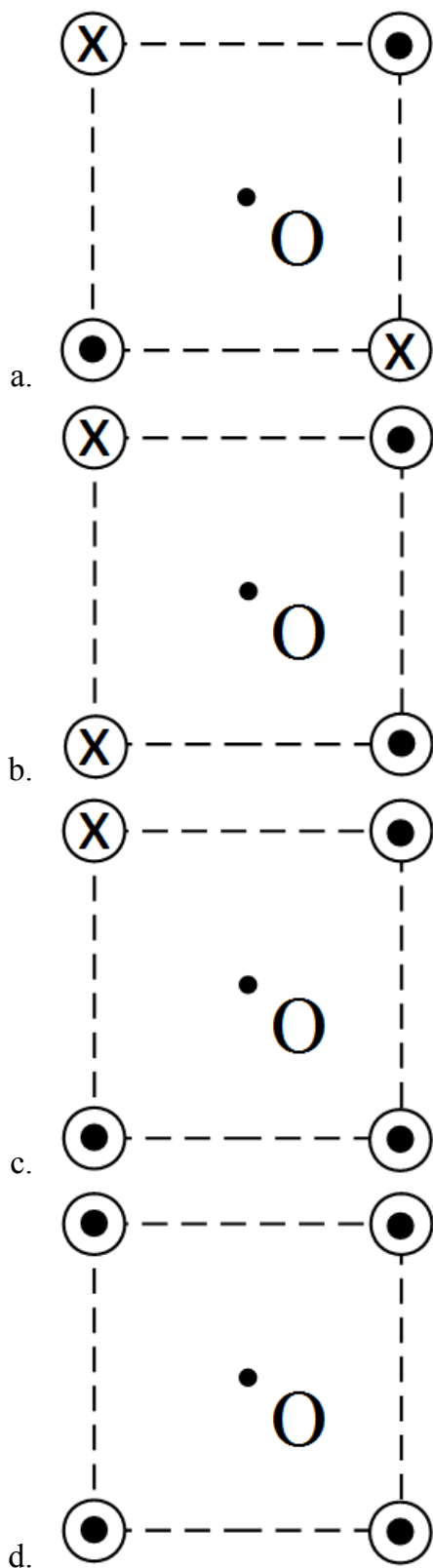

21) A charged particle travels counterclockwise with speed v on a circle in the plane of the page, while a uniform magnetic field B is applied in a perpendicular direction, pointing into the page (as shown below). The period T is the amount of time the particle takes to travel around one complete circle. How would the period change if the speed of the particle was doubled?

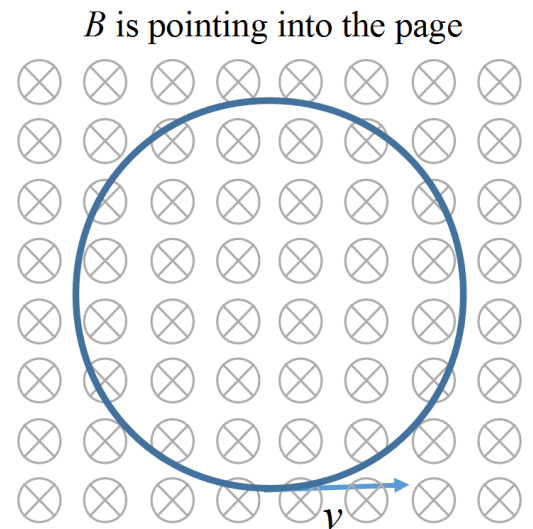

- a. T would increase by a factor of 4.
- b. T would remain unchanged.
- c. T would increase by a factor of 2.
- d. T would decrease by a factor of 2.
- e. T would decrease by a factor of 4.

22) Three long, parallel straight wires A, B and C carry a constant current of $I = 3\text{ A}$ each. The direction of the current of each wire is as indicated in the figure below. The length of the wires is $L = 1\text{ m}$ and the diameter is $D = 8\text{ mm}$. Wires A and B are stuck to each other but electrically insulated from each other. We call the combination of wires A and B a “double wire AB”. The distance from the center of C to the center of A is $r = 2\text{ cm}$.

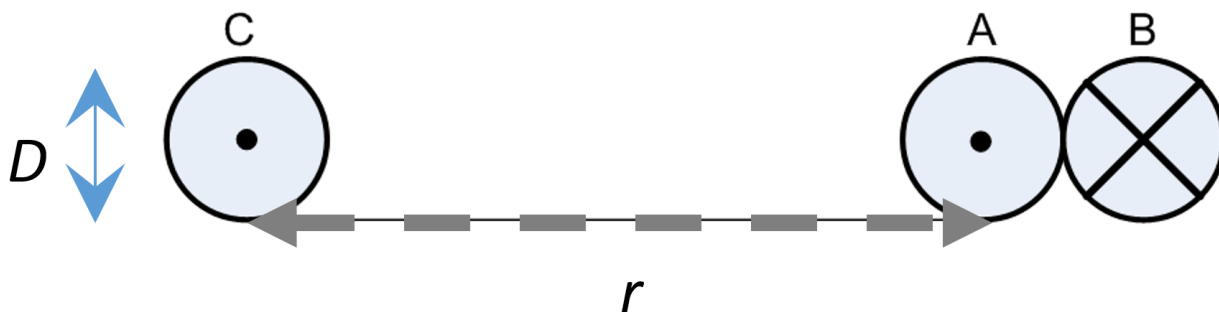

What is the net force on the double wire AB due to wire C?

- a. $F = 1.5 \times 10^{-4}\text{ N}$
- b. $F = 0\text{ N}$
- c. $F = 2.6 \times 10^{-5}\text{ N}$

23) A particle of charge $-|q|$ moves in the positive x -direction with speed v . There is a uniform electric field \mathbf{E} of magnitude $|E|$ pointing in the positive y -direction and a uniform magnetic field \mathbf{B} pointing in the negative z -direction. What must be the magnitude of the magnetic field, $|E|$, such that the particle does not accelerate? (Hint: Pay careful attention to the given direction of \mathbf{E} and \mathbf{B}).

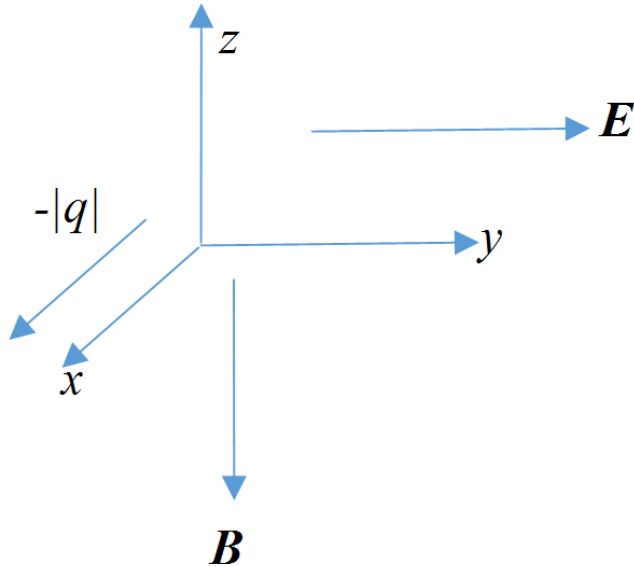

- a. $|B| = |E|$
- b. The charge will accelerate for any magnetic field \mathbf{B} pointing in the negative z -direction.
- c. $|B| = |E|/v$

24) A negatively charged particle enters a uniform magnetic field from the south and is pushed to the east.

In which direction does the magnetic field point?

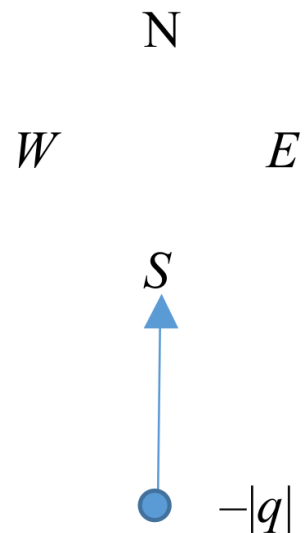

- a. The magnetic field points into the page.
- b. The magnetic field points out of the page.

The next two questions pertain to the situation described below.

A negatively charged particle with charge $q = -3e$ enters a uniform magnetic field $B = 0.3 \text{ T}$ pointing out of the page with a speed of $v = 10^6 \text{ m/s}$ and sweeps out a half circle of radius $r = 5.9 \text{ cm}$ before leaving the field.

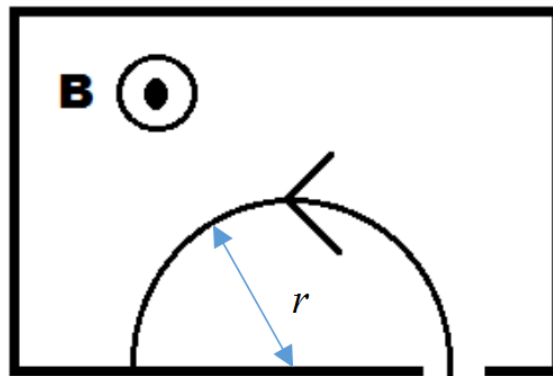

25) What is the particle's mass?

- a. More information is required to determine the mass of the particle.
- b. $m = 2.8 \times 10^{-20} \text{ kg}$
- c. $m = 8.5 \times 10^{-27} \text{ kg}$
- d. $m = 8.5 \times 10^{-21} \text{ kg}$
- e. $m = 2.8 \times 10^{-26} \text{ kg}$

26) What is the speed v of the particle upon exiting the region with the B field?

- a. $v = 10^5 \text{ m/s}$
- b. $v = 10^7 \text{ m/s}$
- c. $v = 10^4 \text{ m/s}$
- d. $v = 0 \text{ m/s}$
- e. $v = 10^6 \text{ m/s}$

Physics 102 Hour Exam 2 – SP15

1. A
2. B
3. C
4. A
5. A
6. C
7. A
8. A
9. B
10. C
11. C
12. C
13. A
14. D
15. A
16. D
17. A
18. D
19. A
20. B
21. B
22. C
23. B
24. A
25. C
26. E

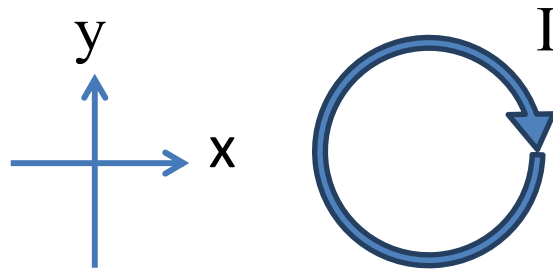

1. The picture above shows a top-down view of a solenoid. The current I in the solenoid flows clockwise. Which way does the magnetic field point at the center of the solenoid?

- a. Into the page
- b. Out of the page
- c. Along the $+y$ direction
- d. Along the $-y$ direction
- e. Along the $+x$ direction

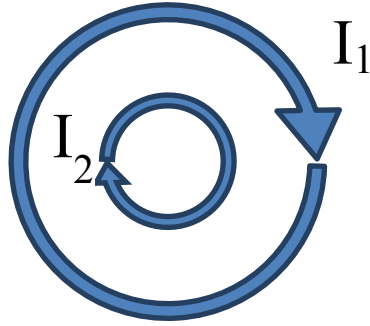

3. Suppose a smaller diameter solenoid is placed inside a larger diameter solenoid, as shown in the top-down view above. The first has current I_1 and turns per unit length n_1 . The second has current I_2 and turns per unit length n_2 . Both currents are in the clockwise direction. What is the magnitude of the magnetic field at the center of the solenoids?

- a. $B=0$
- b. $B=\mu_0|I_1n_1+I_2n_2|$
- c. $B=\mu_0|I_1n_1-I_2n_2|$
- d. $B=\mu_0|I_1n_2+I_2n_1|$
- e. $B=\mu_0|I_1n_2-I_2n_1|$

4. If you have a solenoid 13m long that consists of 169 turns, what current must you put through it to produce a $50\mu\text{T}$ magnetic field at the center?

- a. 0.2A
- b. 3.1A
- c. 39.8A
- d. 235A
- e. 3060A

The next two questions refer to the following situation:

As shown in the picture below, two long, straight wires are separated by 2m. The point P lies at the midpoint of the line connecting the two wires.

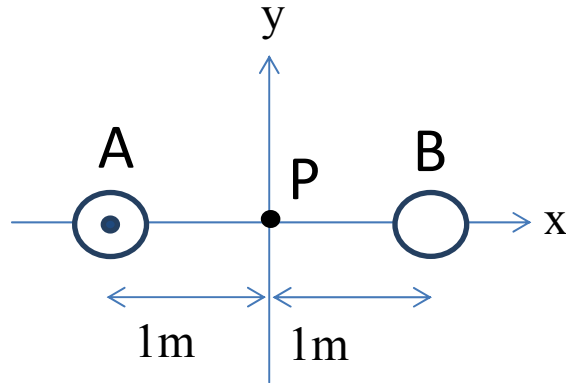

5. If the current through wire A is 1 A and no current flows through wire B, what is the magnitude of the magnetic field at point P?

- a. 1×10^{-7} T
- b. 2×10^{-7} T
- c. 4×10^{-7} T
- d. 3.14×10^{-7} T
- e. 0.318×10^{-7} T

6. What is the direction of the magnetic field at point P if 1A flows through wire B into the page?

- a. Into the page
- b. Out of the page
- c. +y direction
- d. -y direction
- e. The magnetic field would be zero

The next two questions pertain to the same situation.

10. A square loop (connected to a battery not shown in the picture) has a current I flowing in the loop as indicated below and lies in the x - y plane. The loop is in an external uniform magnetic field B which points in the x direction. The left side of the loop is labeled s . In which direction does the loop rotate?

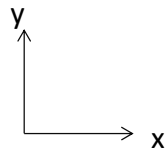
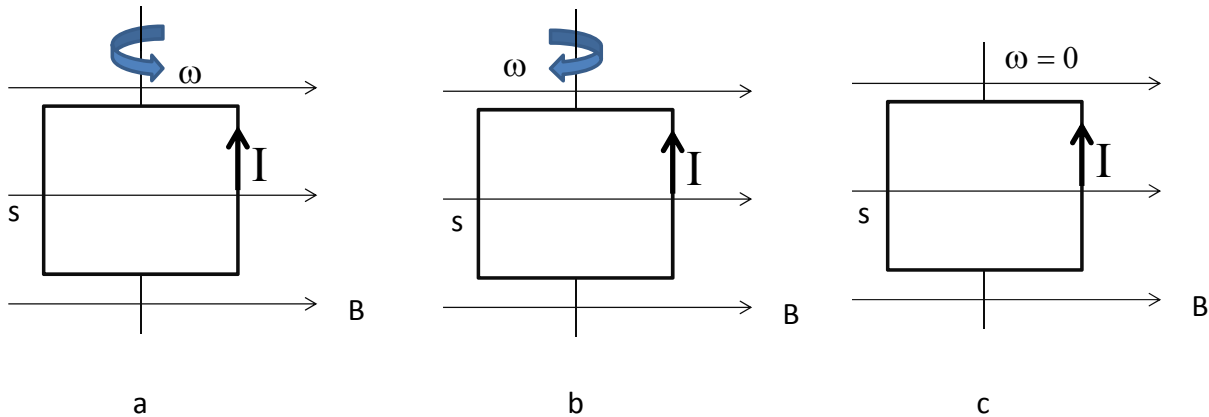

- a. side s rotates out of the page
- b. side s rotates into the page
- c. the loop does not rotate

11. The current in the loop is $I = 2.2$ A, the side is 10 cm, the magnetic field $B = 2$ T and the number of turns in the loop $N = 3$. What is the magnitude of the torque on the loop?

- a. $\tau = 0.023$ N-m
- b. $\tau = 0.974$ N-m
- c. $\tau = 0.132$ N-m

The next two questions pertain to the following situation:

The picture below shows three wires oriented vertically, each spaced a distance $d = 10$ cm apart. Wire A has current $I_A = 5$ A pointing out of the page (+z direction) and Wire B has current $I_B = 5$ A pointing into of the page (-z direction). Wire C has unknown current and direction. Each wire is 10 m long.

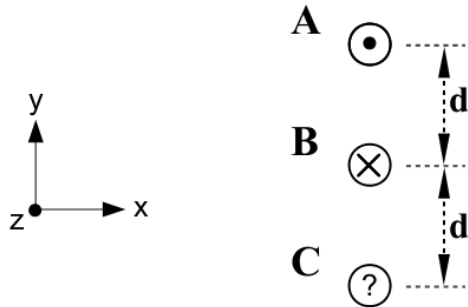

12. If we want current B to have a net force of zero on it, then in what direction should current C point?

- a. out of the page
- b. into the page
- c. no current is necessary

13. Assume the direction and magnitude of the current in wire C is such that the net force on wire B is zero. In which direction could an external magnetic field B_{ext} be applied so that there continues to be no net force on wire B?

- a. +x
- b. +y
- c. +z

The next two questions pertain to the following situation:

A charge with $m=1\text{ kg}$ and $Q=+1.0\text{ C}$ enters into a parallel plate capacitor with $E=100.0\text{ V/m}$. An external magnetic field with magnitude of 2.0 T is applied in some direction. Ignore the force of gravity.

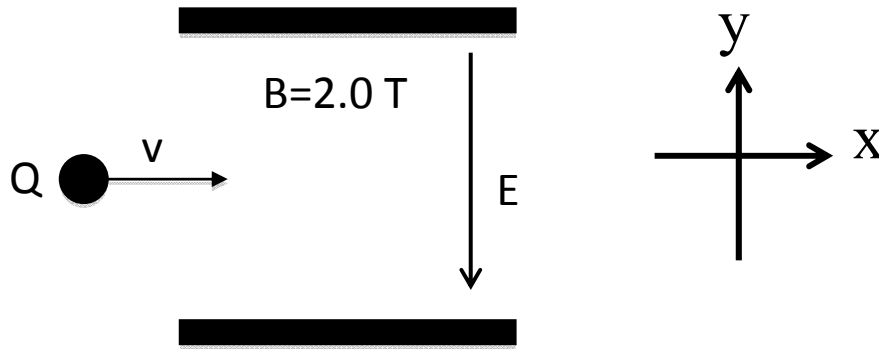

15. Which direction should the magnetic field point to make it possible for the particle to travel in a straight line?

- a. Into the page
- b. Out of the page
- c. $+y$
- d. $-y$
- e. $+x$

16. What is the initial speed of this charge if it travels in a straight line?

- a. 40 m/s
- b. 50 m/s
- c. 100 m/s
- d. 0.02 m/s
- e. 65 m/s

The next question pertains to the following situation:

A charged particle with charge $Q = 1\text{ C}$ is travelling at $v = 1\text{ m/s}$ in the $+x$ direction toward a square with side length 5 m containing magnetic field $B = 3\text{ Tesla}$, directed into the page. The particle enters the field at $y = 2\text{ meters}$ above the bottom of the square. There is no magnetic field anywhere outside the square.

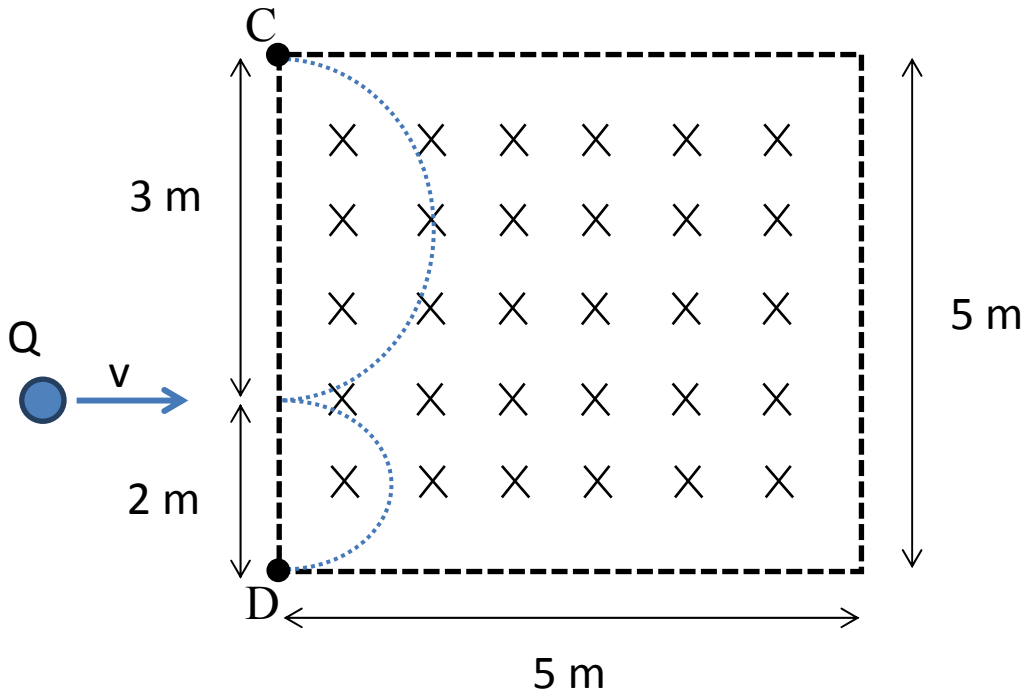

17. The particle travels in a complete semi-circle. Given the direction of the magnetic field, this means that the particle exits at either point C or D, which you must determine. What is the mass of the particle?

- a. 0.3 kg
- b. 1 kg
- c. 3 kg
- d. 4.5 kg
- e. 7.5 kg

KEY

Fall 2011 – Exam 2

1. a
2. b
3. b
4. b
5. b
6. c
7. a
8. b
9. b
10. a
11. c
12. a
13. c
14. d
15. a
16. b
17. d
18. e
19. d
20. c
21. a
22. a
23. d
24. b
25. b
26. d

The next two questions pertain to the following situation:

Two long straight wires are placed parallel to one another 9 cm apart, as shown in the figure. The current in wire 1 is oriented out of the page, and the current in wire 2 is oriented into the page. A point P is located 6 cm to the right of wire 2.

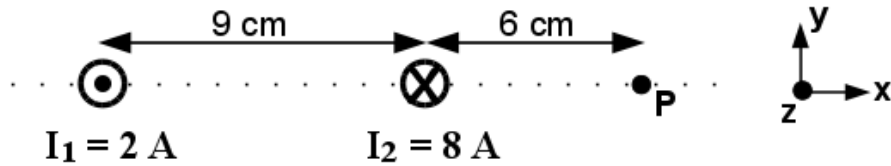

18. Calculate the net magnetic field in the y direction at the point P.

- a. $B_{\text{net}} = +1.04 \times 10^{-5}\text{ T}$
- b. $B_{\text{net}} = +3.99 \times 10^{-5}\text{ T}$
- c. $B_{\text{net}} = +6.72 \times 10^{-5}\text{ T}$
- d. $B_{\text{net}} = -5.34 \times 10^{-5}\text{ T}$
- e. $B_{\text{net}} = -2.40 \times 10^{-5}\text{ T}$

19. The net magnetic field due to the two wires equals zero at a point in the region between the two wires.

- a. True
- b. False

The next three questions pertain to the following situation:

A particle of mass 5×10^{-8} kg and speed $v_i = 3000$ m/s enters a region with magnetic field B_{bottom} , which is perpendicular to the plane of the paper. The magnitude of B_{bottom} is not known. The particle follows a quarter-circle trajectory and enters another region with a different magnetic field B_{top} , which is also perpendicular to the plane of the paper. It again follows a quarter-circle trajectory. The magnitude of B_{top} is also not known. The radius of curvature for the motion in the top region is larger than that in the bottom region ($r_{\text{top}} > r_{\text{bottom}}$).

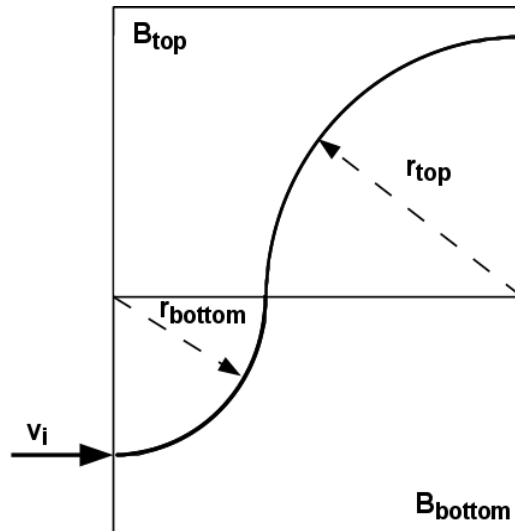

20. Given that the particle has charge $q = +6 \mu\text{C}$, in which direction does B_{top} point?

- into the page
- out of the page

21. Which is true regarding the relationship between B_{top} and B_{bottom} ?

- $B_{\text{top}} < B_{\text{bottom}}$
- $B_{\text{top}} = B_{\text{bottom}}$
- $B_{\text{top}} > B_{\text{bottom}}$

22. Calculate B_{top} if r_{top} is 1.35 meters.

- $B_{\text{top}} = 4.9$ T
- $B_{\text{top}} = 18.5$ T
- $B_{\text{top}} = 68.4$ T
- $B_{\text{top}} = 173$ T
- $B_{\text{top}} = 557$ T

The next two questions pertain to the following situation:

A square loop with sides of unknown length L is carrying a current $I = 3$ A. The loop is oriented in space at a 35° angle with respect to the horizontal. The current flows into the page at the top of the loop and out of the page at the bottom of the loop, as shown in the picture below. A magnetic field of magnitude $B = 2.8$ mT is applied in an unknown direction.

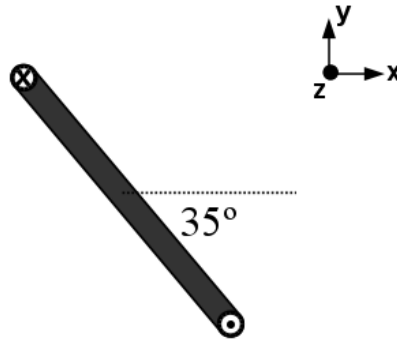

23. In which direction could the magnetic field be oriented for the torque due to the magnetic field to cause the loop to rotate in the counter-clockwise (CCW) direction as viewed in the picture above?

- a. +x
- b. +y
- c. +z

24. Presume the magnetic field is now directed downward, in the $-y$ direction. The torque on the loop is measured to be $\tau = 6.4 \times 10^{-6}$ N m. Calculate the length L of the sides of the square.

- a. $L = 0.381$ m
- b. $L = 0.192$ m
- c. $L = 0.633$ m
- d. $L = 0.085$ m
- e. $L = 0.037$ m

The next two questions pertain to the following situation:

A positively charged particle moving with speed $v = 250$ m/s enters a region of magnetic field of magnitude $B = 300$ T oriented out of the page, as shown in the figure. The magnetic force on the particle is measured to be 15×10^{-9} N.

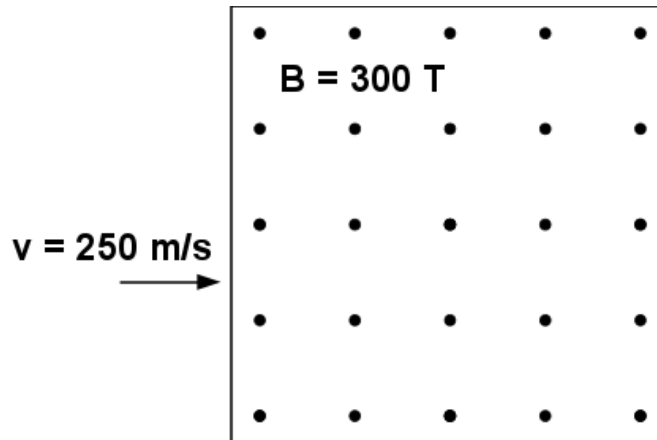

25. Calculate the charge Q of the particle.

- a. $Q = 1 \times 10^{-13}$ C
- b. $Q = 2 \times 10^{-13}$ C
- c. $Q = 3 \times 10^{-13}$ C
- d. $Q = 4 \times 10^{-13}$ C
- e. $Q = 5 \times 10^{-13}$ C

26. An electric field is now applied in the same region as the magnetic field. In which direction must the electric field be oriented so that the charge travels a straight-line trajectory through the region of the two fields?

- a. up
- b. down
- c. into the page
- d. out of the page
- e. right

**Check to make sure you bubbled in all your answers.
Did you bubble in your name, exam version and network-ID?**

KEY

Spring 2012 – Exam 2

1. c
2. e
3. a
4. c
5. a
6. b
7. a
8. b
9. c
10. c
11. e
12. a
13. d
14. c
15. a
16. c
17. e
18. e
19. b
20. b
21. a
22. b
23. a
24. e
25. b
26. a

8. A 10^{-5} m long carbon nanotube with a mass of 2×10^{-20} kg is used as a wire. As shown, the nanotube carries 10^{-9} A of current to the right. If the Earth's magnetic field is 5×10^{-5} T and points into the page, what is the acceleration of the nanotube?

- a. 9.8 m/s^2
- b. 25 m/s^2
- c. $5 \times 10^{-9} \text{ m/s}^2$
- d. 0.04 m/s^2
- e. $2.5 \times 10^{-19} \text{ m/s}^2$

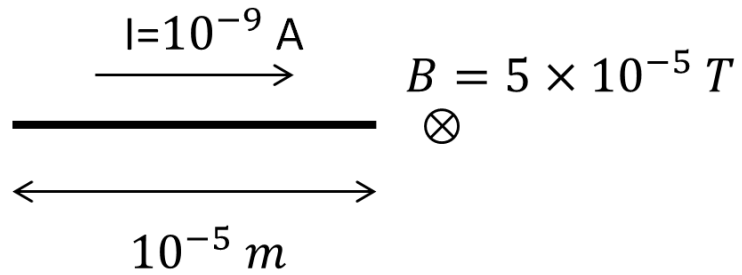

19. A long straight wire carries current, I_1 . It produces a magnetic field, B_1 , at a distance, d_1 , from the wire. Now, both the current and the distance are doubled. Compare the new magnetic field, B_2 , to the original field, B_1 .

- a. $B_2 < B_1$
- b. $B_2 = B_1$
- c. $B_2 > B_1$

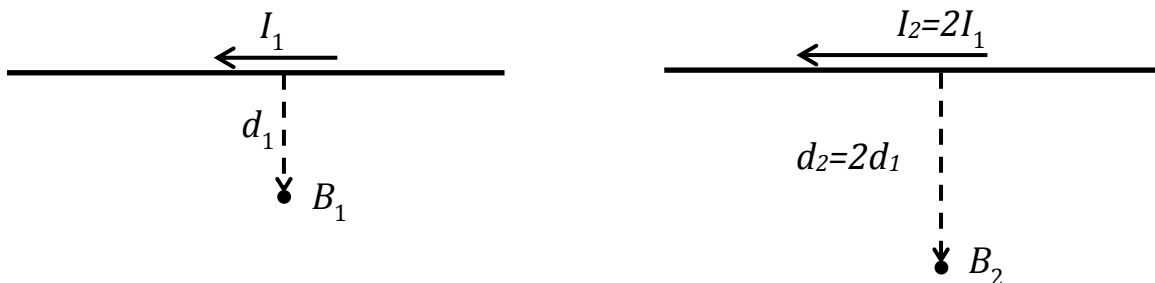

20. Two wires carry current perpendicular to the page. The magnitudes of the two currents are equal, but one is into and one is out of the page, as shown. Where on the line is the magnetic field zero?

- a. Somewhere in region A
- b. Somewhere in region B
- c. At point C
- d. Somewhere in region D
- e. The magnetic field is not zero anywhere on the line.

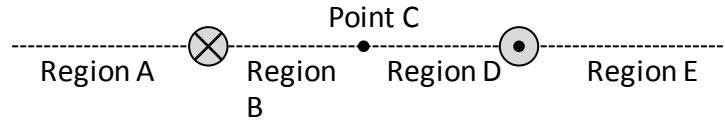

21. The coil of an MRI solenoid is 8 cm long and has a 0.025 m radius. There are 500 turns of wire. How much current is needed to produce a 3 T magnetic field inside the solenoid? (Note: This device images mice, not humans!)

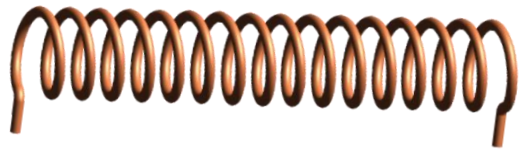

- a. $I = 6.0 \times 10^{-10}$ A
- b. $I = 382$ A
- c. $I = 4774$ A
- d. $I = 1.91 \times 10^5$ A
- e. $I = 1.49 \times 10^{10}$ A

The next two questions pertain to this situation:

A charged dust particle ($m = 3 \times 10^{-21}$ kg, $q = +1.6 \times 10^{-16}$ C) is accelerated from rest by an electric field through a 10^3 V potential difference. The magnetic field is zero in the electric field region. It then enters a region that contains a uniform 1.5 T magnetic field that points into the page. $E = 0$ in the magnetic field region.

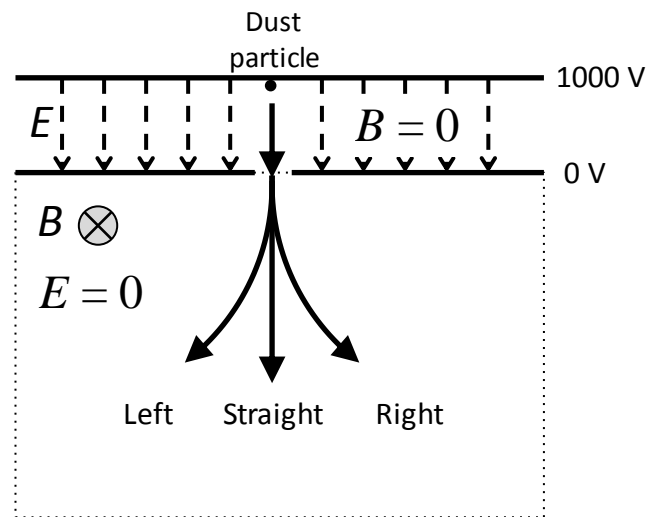

22. Which of the three paths shown in the figure does the dust particle follow?

- a. Left
- b. Straight
- c. Right

23. What is the radius of curvature of the particle's motion in the magnetic field region?

- a. $R = 0.022$ m
- b. $R = 0.129$ m
- c. $R = 1.53$ m
- d. $R = 15.3$ m
- e. $R = 1096$ m

24. A negatively charged particle, $-q$, is moving in the $+z$ direction in a region that contains a uniform magnetic field along the $-x$ direction. In what direction must an electric field point so that there is no net force on the particle?

- Along $+x$
- Along $-x$
- Along $+y$
- Along $-y$
- Along $-z$

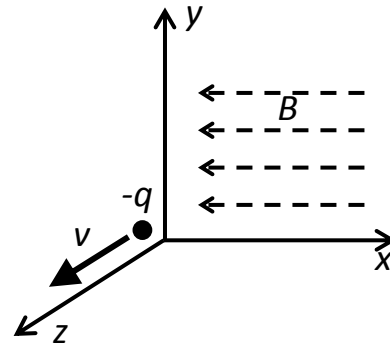

25. An electron (mass: $m = 9.11 \times 10^{-31}$ kg, and charge: $q = -1.60 \times 10^{-19}$ C) is initially at point P_1 with speed $v_1 = 3.1 \times 10^4$ m/s. It is moving in a uniform magnetic field of strength $B = 0.15$ T. How fast (v_2) is the electron moving when it reaches point P_2 , which is $d_1 = 2.5 \times 10^{-7}$ m along B and $d_2 = 1.5 \times 10^{-7}$ m perpendicular to B with respect to P_1 ?

- $v_2 = 1.1 \times 10^4$ m/s
- $v_2 = 3.1 \times 10^4$ m/s
- $v_2 = 5.1 \times 10^4$ m/s
- $v_2 = 6.7 \times 10^4$ m/s
- The electron does not have enough energy to reach point P_2 .

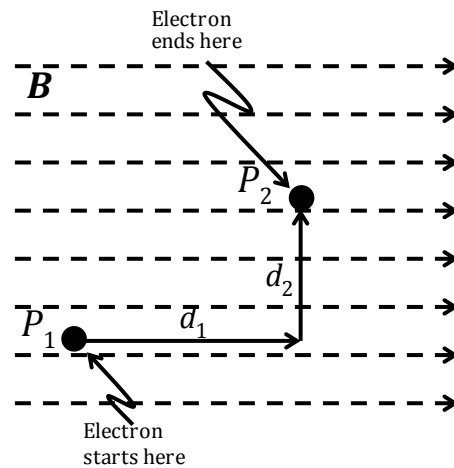

The next two questions pertain to this situation.

A square loop with sides, $L = 0.1$ m, lies in the x - z plane and carries electric current, $I = 3.7$ A, in the direction shown. The magnetic field, $B = 0.22$ T, lies in the x - y plane, rotated away from the $+y$ direction by an angle θ , as shown.

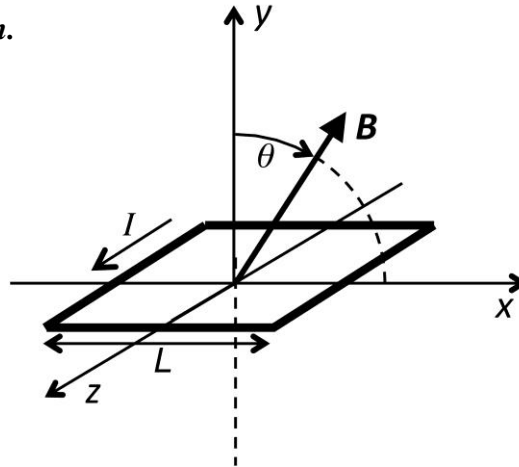

26. What value of θ would make the torque on the loop equal to zero?

- a. $\theta = 0^\circ$
- b. $\theta = 45^\circ$
- c. $\theta = 90^\circ$
- d. $\theta = -90^\circ$
- e. The torque is never equal to zero.

27. For $\theta = 37^\circ$, how much torque, τ , is exerted on the loop?

- a. $\tau = 4.90 \times 10^{-3}$ N·m
- b. $\tau = 6.50 \times 10^{-3}$ N·m
- c. $\tau = 8.14 \times 10^{-3}$ N·m
- d. $\tau = 2.23 \times 10^{-2}$ N·m
- e. $\tau = 8.14 \times 10^{-2}$ N·m

KEY

Exam 2 – Fall 2012

1. c
2. a
3. b
4. a
5. e
6. b
7. e
8. b
9. d
10. c
11. b
12. a
13. c
14. b
15. b
16. c
17. b
18. c
19. b
20. e
21. b
22. c
23. b
24. c
25. b
26. a
27. a

The next three questions pertain to the following situation:

A beam of particles is sent through a velocity selector in order to isolate charges of a particular speed to enter into a mass spectrometer (see below). In the region of the velocity selector, the electric field $E = 2500 \text{ N/C}$ upward and the magnetic field B_1 is of unknown magnitude out of the page. The speed of the selected charged particles is $v = 2.2 \times 10^8 \text{ m/s}$. Ignore any effects due to gravity.

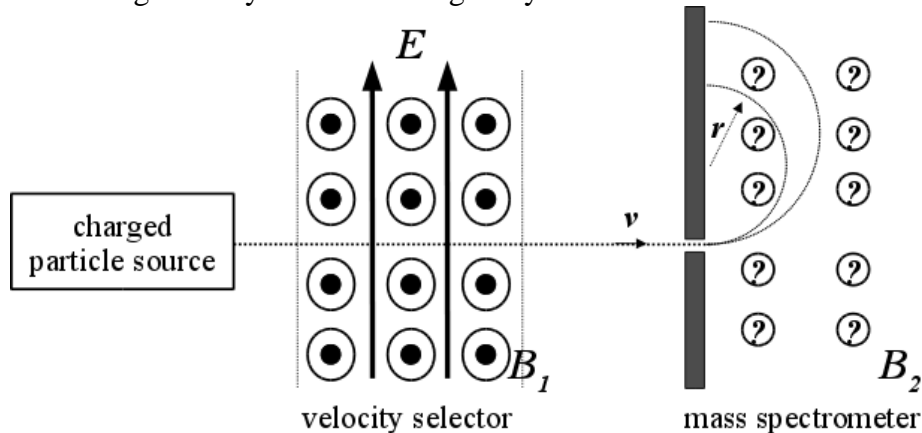

- The velocity selector is set up to select positive charges *only*.
 - T
 - F
- What is the magnitude of the magnetic field B_1 in the region of the velocity selector?
 - $B_1 = 0.13 \mu\text{T}$
 - $B_1 = 11 \mu\text{T}$
 - $B_1 = 56 \mu\text{T}$
 - $B_1 = 84 \mu\text{T}$
 - $B_1 = 166 \mu\text{T}$
- The selected charged particles are then sent into a mass spectrometer to identify the composition of the stream from the source. The magnetic field $B_2 = 5.5 \mu\text{T}$ in this region is oriented such that the charged particles deflect in semicircles as shown. For a certain particle in the beam, the mass is measured to be $m = 1.56 \times 10^{-24} \text{ kg}$ for following a path of radius $r = 7.5 \text{ mm}$. What is the charge q of the particle?
 - $q = 41.8 \text{ nC}$
 - $q = 96.2 \text{ nC}$
 - $q = 8.3 \text{ nC}$
 - $q = 0.368 \text{ nC}$
 - $q = 25.0 \text{ nC}$

7. A proton is moving toward a bar magnet. What is the direction of the magnetic force on the proton if it travels in the $+y$ direction at the point designated Q in the figure? (The point Q is directly below the center of the bar magnet.)

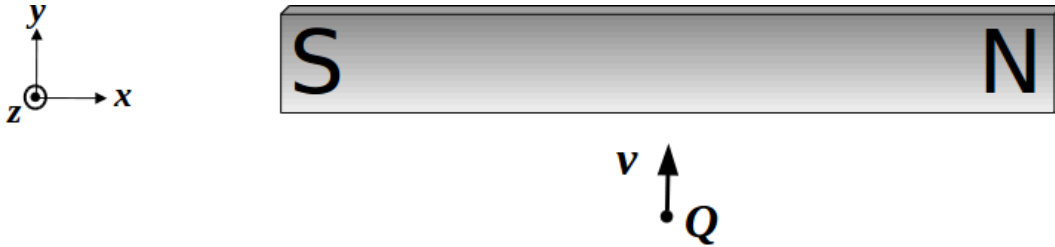



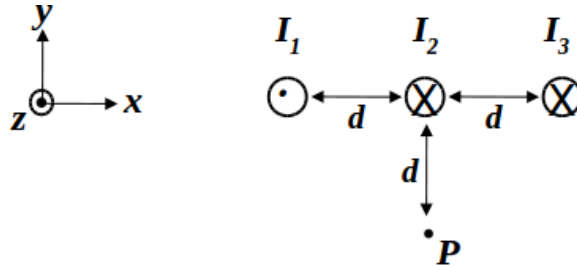

- left
- right
- into the page
- out of the page
- There is no magnetic force on the proton.

The next three questions pertain to the following situation:

Three infinitely long current-carrying wires are placed in a horizontal line, with a distance d between each. The magnitudes of the currents in each of the wires are $I_1 = I_2 = I_3 = I$. Point P is located a distance d directly under wire 2.



10. What is the general direction of the net magnetic field at point P due to the three wires?

- a.  b.  c.  d.  e. 

11. What is the y -component of the magnetic field at point P ?

- a. $B_y = +\frac{2\mu_0 I}{\pi d}$
 b. $B_y = 0$
 c. $B_y = +\frac{\mu_0 I}{2\pi d}$
 d. $B_y = -\frac{2\mu_0 I}{\pi d}$
 e. $B_y = +\frac{\mu_0 I}{\sqrt{2}\pi d}$

12. What is the magnitude of the net force on a length L of wire 2 due to the other two wires?

- a. $F_{2,net} = \frac{\mu_0 I^2 L}{\pi d}$
 b. $F_{2,net} = \frac{2\mu_0 I^3 L}{\pi d}$
 c. $F_{2,net} = \frac{3\mu_0 I^2 L}{2\pi d}$

The next two questions pertain to the following situation:

A single wire loop is placed in a uniform magnetic field as shown in the diagram. The loop has radius $R = 15\text{ cm}$. The current in the loop is measured to be $I = 3.33\text{ A}$ in the counterclockwise direction, as indicated in the figure. The net torque this loop experiences is measured to be $\tau = 5.25 \times 10^{-3}\text{ N}\cdot\text{m}$.

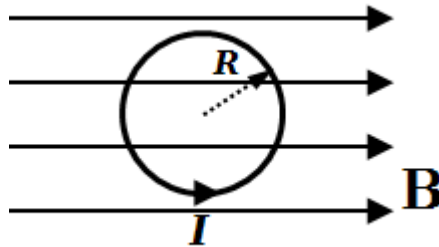

13. What is the magnitude of the magnetic field?

- a. $B = 66.7\text{ mT}$
- b. $B = 22.3\text{ mT}$
- c. $B = 97.2\text{ mT}$
- d. $B = 343\text{ mT}$
- e. $B = 5.6\text{ mT}$

14. Which picture below shows the direction of rotation at the moment the loop is allowed to rotate freely?

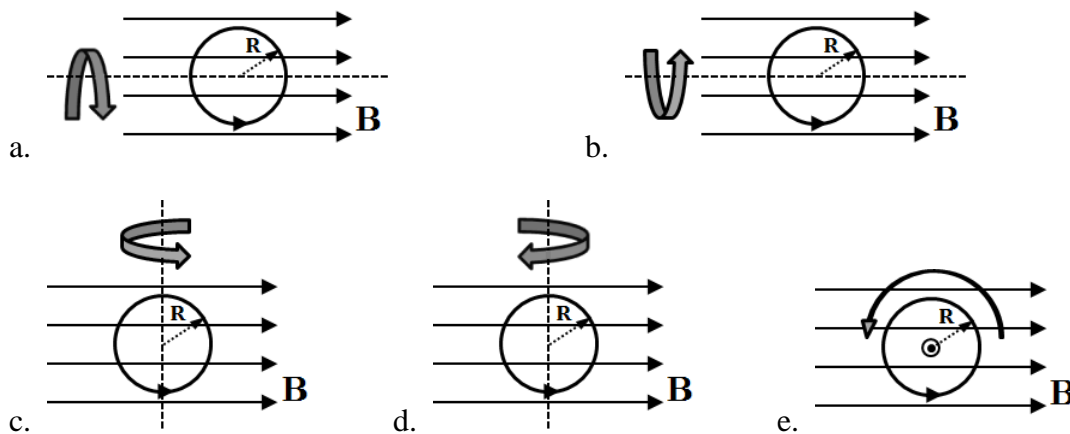

KEY

Exam 2 – Spring 2013

1. b
2. b
3. c
4. b
5. bc
6. a
7. d
8. b
9. b
10. a
11. c
12. a
13. b
14. c
15. a
16. c
17. c
18. a
19. b
20. b
21. b
22. c
23. c
24. b
25. a
26. a

The next three questions pertain to the situation described below.

A negatively-charged particle, moving at a speed $v = 165 \text{ m/s}$, enters a region of width $d = 0.87 \text{ m}$ that contains a uniform magnetic field of magnitude $B = 1.7 \text{ T}$ pointing out of the page, as shown in the figure. The mass and the magnitude of the charge of the particle are unknown.

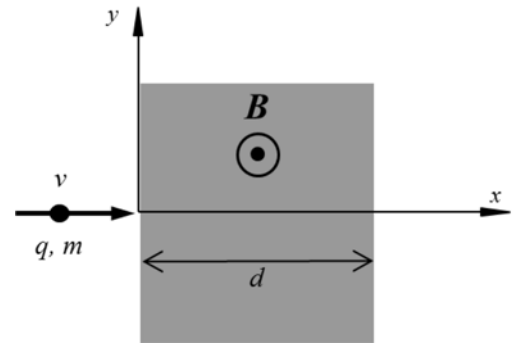

1) In which direction will the particle be deflected? Show how apply RHR (fingers point in ____ etc) 75%

- a. Up
- b. Down

Fingers in direction of v (right/positive x)
 Palm in direction of B (out of page $+z$)
 Thumb = direction of force on positive charge (down/ $-y$)
 Negative charge so force is opposite (up)

2) What is the minimum mass-to-charge ratio (m/q) such that the particle can traverse the whole shaded region and exit through the right? show work starting w/ $F=ma$, and solve

- a. $m/q = 0.0064 \text{ kg/C}$
- b. $m/q = 0.0112 \text{ kg/C}$
- c. $m/q = 0.00427 \text{ kg/C}$
- d. $m/q = 0.00345 \text{ kg/C}$
- e. $m/q = 0.00896 \text{ kg/C}$

$$\begin{aligned}
 F &= ma \\
 qvB \sin(90) &= mv^2 / r \\
 m/q &= B r / v \\
 &= (1.7) (0.87) / (165) \\
 &= 8.96e-3
 \end{aligned}$$

3) Now an electric field of magnitude $E = 78 \text{ N/C}$ is added to the shaded region. What should the speed of the particle be such that it travels in a straight line across the shaded region?

Show work starting w/ $F=ma$

- a. $v = 39.9 \text{ m/s}$
- b. $v = 1.22 \text{ m/s}$
- c. $v = 45.9 \text{ m/s}$
- d. $v = 76.6 \text{ m/s}$
- e. $v = 4.13 \text{ m/s}$

$$\begin{aligned}
 F &= ma \\
 qvB \sin(90) - qE &= 0 \\
 v &= E/B \\
 &= 78 / 1.7 \\
 &= 45.9
 \end{aligned}$$

The next two questions pertain to the situation described below.

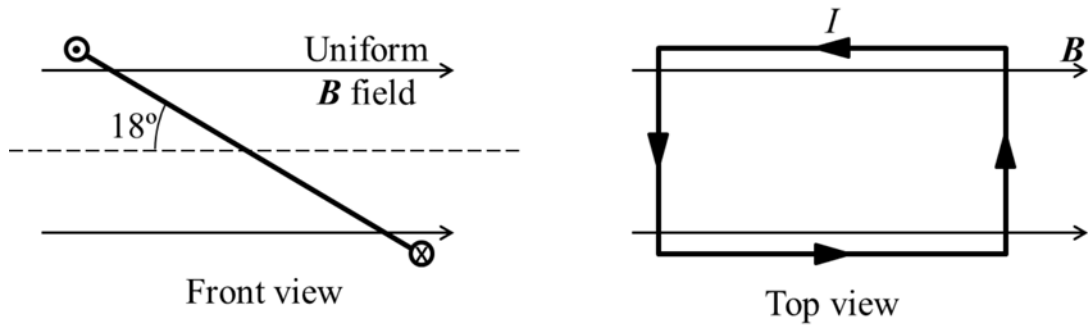

A rectangular loop of area $A = 0.0245 \text{ m}^2$ and carrying a current $I = 3.9 \text{ A}$ is exposed to a uniform magnetic field of magnitude $B = 4.6 \text{ T}$, as shown in the figure.

- 4) What is the magnitude of the torque exerted on the loop? Show work starting w/ expression for torque
- 0.136 Nm
 - 0.153 Nm
 - 0.418 Nm
- 5) As seen from the front, in which direction will the loop rotate? Either show forces on diagram (front view) or explain using dipole moment.
- Clockwise
 - Counterclockwise

The next two questions pertain to the situation described below.

Three long, straight wires, each carrying a current $I = 4.8$ A, are arranged as shown in the figure, with $d = 2$ m and $\theta = 30$ degrees.

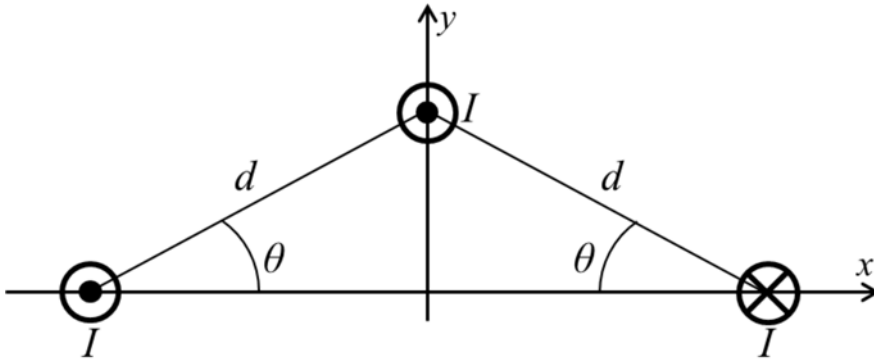

6) What is the magnitude of the total magnetic field at the origin, B_{total} , due to the three wires?

Draw B from each wire, then show calc of x and y components
be sure to show angle, and combine to get Btotal

- $B_{total} = 1.07 \times 10^{-6}$ T
- $B_{total} = 2.07 \times 10^{-6}$ T
- $B_{total} = 1.92 \times 10^{-6}$ T
- $B_{total} = 1.36 \times 10^{-6}$ T
- $B_{total} = 1.47 \times 10^{-6}$ T

7) What is the x component of the net force on one meter of the top wire due to the other two wires?

Draw forces from lower currents, then calculate magnitude using
expression for force between two wires, then calculate
x component. Be sure to label angles

- $F_x = -2.3 \times 10^{-6}$ N
- $F_x = 3.99 \times 10^{-6}$ N
- $F_x = -3.99 \times 10^{-6}$ N
- $F_x = 2.3 \times 10^{-6}$ N
- $F_x = 0$ N

Physics 102 Exam 2 --
Spring 2014

1. a
2. e
3. c
4. c
5. a
6. e
7. c
8. d
9. a
10. b
11. c
12. b
13. b
14. a
15. b
16. a
17. c
18. b
19. c
20. b
21. a
22. b
23. a
24. d
25. a

The next three questions pertain to the situation described below.

Mass spectrometers often contain a device called a velocity selector, which consists of a chamber with perpendicular \vec{E} and \vec{B} fields. The magnitudes of the fields are such that only particles with speed $v_b = 1 \times 10^5 \text{ m/s}$ travel along a straight line trajectory b through the opening at the far end of the chamber.

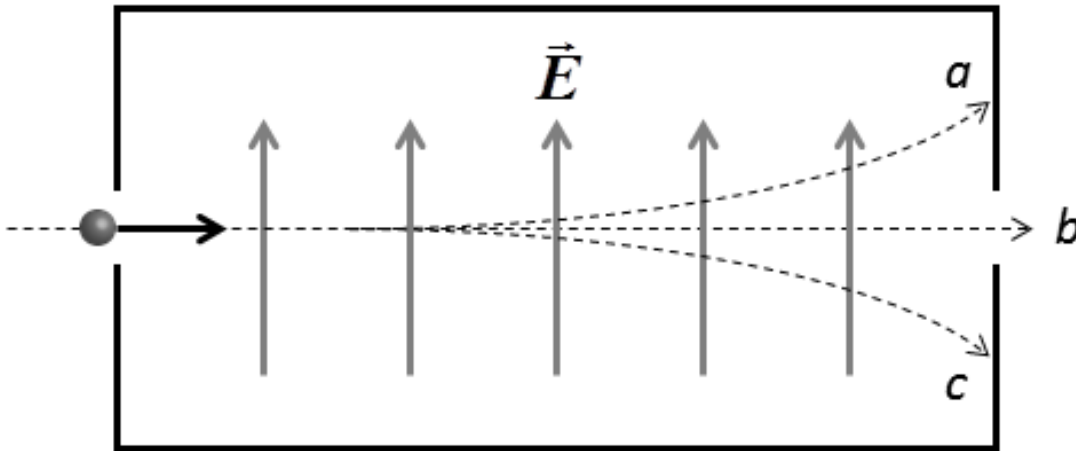

7) Given the \vec{E} field pointing up, which direction of the \vec{B} field would give the observed trajectory b ? You may assume that the particle charge Q is positive.

- a. out of the page
- b. to the right
- c. to the left
- d. into the page
- e. the B field is zero

8) Does your answer to the previous problem change if the charge Q is negative?

- a. No
- b. Yes

9) As shown in the figure, two other particles travel along the dotted trajectories a and c . Which of the following statements must be true? Again assume Q is positive.

- a. $v_a > v_b > v_c$
- b. $v_a = v_b = v_c$
- c. $v_a < v_b < v_c$

The next two questions pertain to the situation described below.

Consider a beam of identical particles with the same charge Q and mass m travelling along the dotted trajectories as they enter a region containing a uniform \vec{B} field pointing into the page.

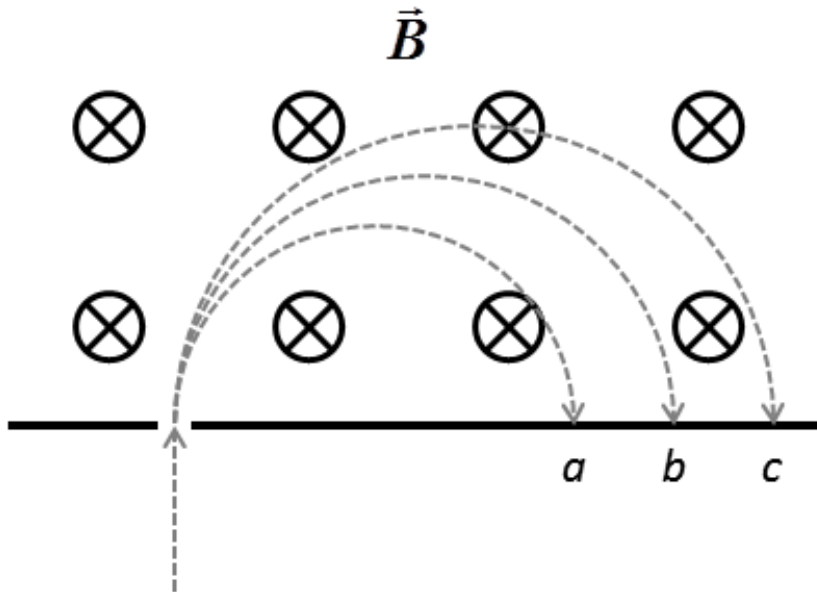

10) What is the sign of the charge of the particles?

- a. *negative*
- b. *the sign cannot be determined*
- c. *positive*

11) Particles moving along which trajectory have the largest speed?

- a. *trajectory c*
- b. *trajectory a*
- c. *trajectory b*

The next three questions pertain to the situation described below.

Consider the following circuit: $R_1 = 10 \Omega$, $R_2 = 8 \Omega$, $R_3 = 3 \Omega$, $\epsilon_1 = 17 \text{ V}$ and $\epsilon_2 = 8 \text{ V}$. Initially the switch is open.

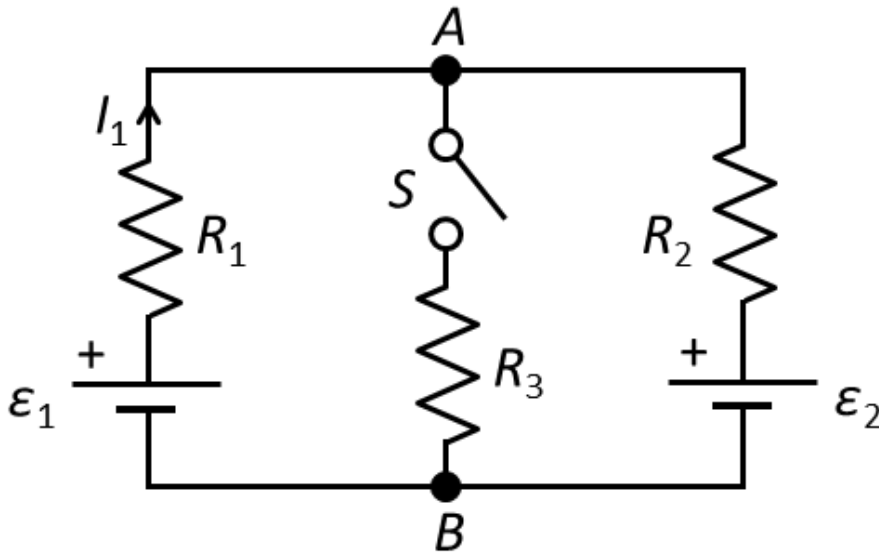

12) You connect a voltmeter at points A and B in the circuit. What is the electric potential difference, $\Delta V_{AB} = V_A - V_B$, measured between those points?

- a. $\Delta V_{AB} = 12 \text{ V}$
- b. $\Delta V_{AB} = 17 \text{ V}$
- c. $\Delta V_{AB} = 9 \text{ V}$

13) Now the switch is closed. Using the same voltmeter as above, you measure the electric potential difference $\Delta V_{AB} = V_A - V_B = 3.33 \text{ V}$. In which direction does the current flow through resistor R_3 ?

- a. *no current flows*
- b. *up*
- c. *down*

14) What is the current I_1 through resistor R_1 after the switch is closed?

- a. $I_1 = 0.8 \text{ A}$
- b. $I_1 = 1.7 \text{ A}$
- c. $I_1 = 1.4 \text{ A}$

The next three questions pertain to the situation described below.

Consider the following RC circuit: $R_1 = 3 \text{ k}\Omega$, $R_2 = 6 \text{ k}\Omega$, $C = 0.4 \text{ }\mu\text{F}$, and $\varepsilon = 9 \text{ V}$. Initially the capacitor is uncharged. At some time, the switch is closed.

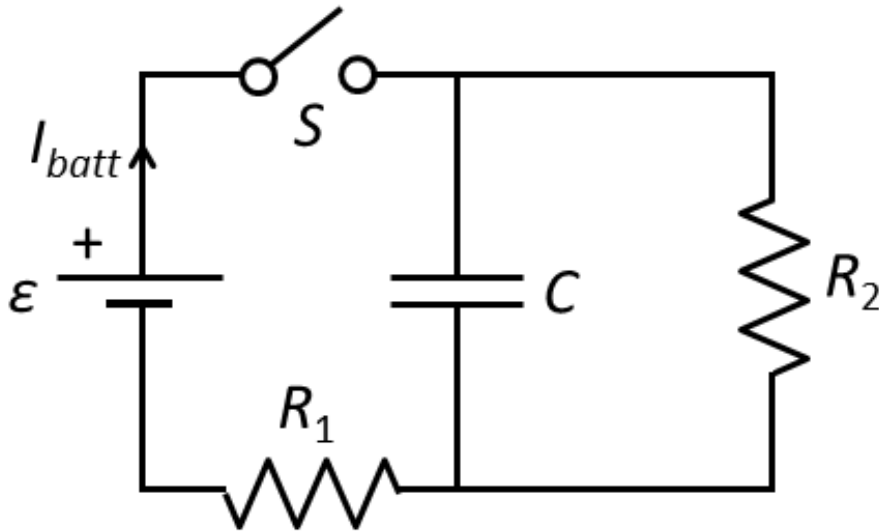

15) What is the current out of the battery, I_{batt} , immediately after the switch is closed?

- a. $I_{batt} = 1 \text{ mA}$
- b. $I_{batt} = 3 \text{ mA}$
- c. $I_{batt} = 1.5 \text{ mA}$
- d. $I_{batt} = 0 \text{ mA}$
- e. $I_{batt} = 22 \text{ mA}$

16) What is the current out of the battery, I_{batt} , a long time after the switch is closed?

- a. $I_{batt} = 1.5 \text{ mA}$
- b. $I_{batt} = 22 \text{ mA}$
- c. $I_{batt} = 0 \text{ mA}$
- d. $I_{batt} = 3 \text{ mA}$
- e. $I_{batt} = 1 \text{ mA}$

17) How much time does it take for the charge Q to decrease to 50% of its initial value after the switch is re-opened?

- a. $t_{50\%} = 1.7 \text{ ms}$
- b. $t_{50\%} = 0.83 \text{ ms}$
- c. $t_{50\%} = 2.5 \text{ ms}$

The next three questions pertain to the situation described below.

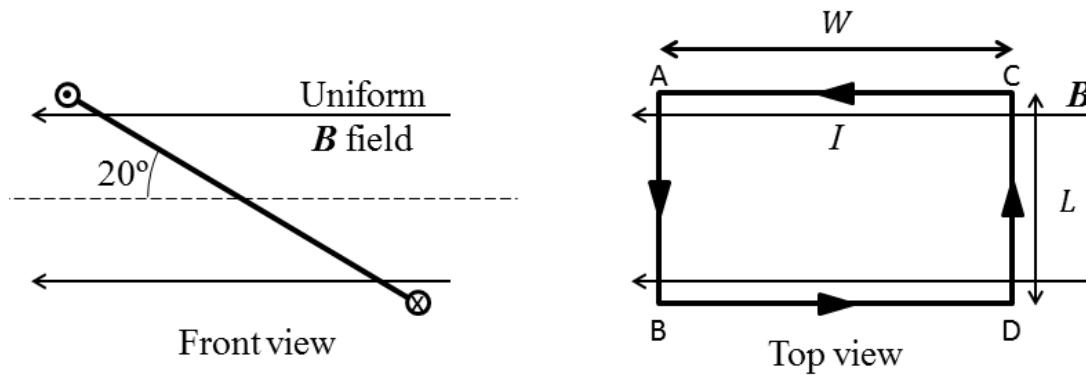

A rectangular loop of length $L = 0.445 \text{ m}$ and width $W = 0.285 \text{ m}$ carries a current $I = 3.9 \text{ A}$ is exposed to a uniform magnetic field of magnitude $B = 5.5 \text{ T}$, as shown in the figure.

18) What is the magnitude of the force experienced on wire segment **AB**?

- a. $F_{AB} = 2.09 \text{ N}$
- b. $F_{AB} = 3.26 \text{ N}$
- c. $F_{AB} = 9.55 \text{ N}$
- d. $F_{AB} = 8.97 \text{ N}$
- e. $F_{AB} = 5.74 \text{ N}$

19) What is the magnitude of the torque exerted on the loop?

- a. 2.56 Nm
- b. 1.06 Nm
- c. 0.93 Nm

20) As seen from the front, in which direction will the loop rotate?

- a. Counterclockwise
- b. Clockwise

The next three questions pertain to the situation described below.

Three long, straight wires, are arranged as shown in the figure:

$a = 3.5\text{ m}$, $b = 2\text{ m}$ and $\theta = 30^\circ$. Each wire carries a current $I = 8.8\text{ A}$

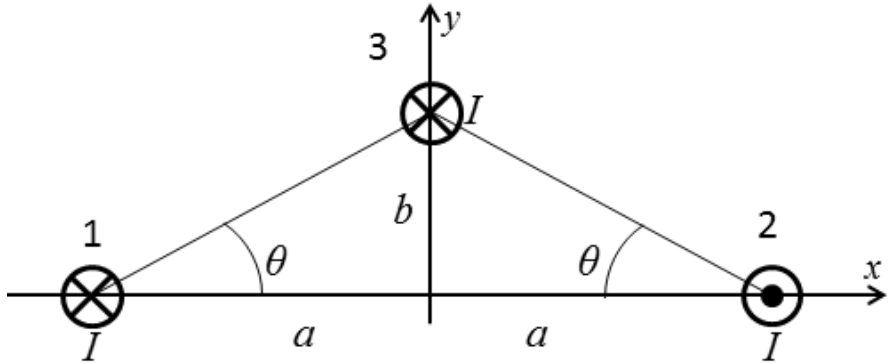

21) Which vector best represents the direction of the total magnetic field at the origin due to the three wires?



- a. *Figure B*
- b. *Figure C*
- c. *Figure D*
- d. *Figure E*
- e. *Figure A*

22) What is the magnitude of the total magnetic field at the origin, B_{total} , due to the three wires?

- a. $B_{total} = 9.76 \times 10^{-7}\text{ T}$
- b. $B_{total} = 1.24 \times 10^{-6}\text{ T}$
- c. $B_{total} = 1.34 \times 10^{-6}\text{ T}$
- d. $B_{total} = 1.75 \times 10^{-6}\text{ T}$
- e. $B_{total} = 1.89 \times 10^{-6}\text{ T}$

23) What is the direction of the net force on one meter of Wire 3 due to the other two wires?

- a. *+x-direction*
- b. *0*
- c. *+y-direction*
- d. *-y-direction*
- e. *-x-direction*

KEY

Exam 2 – Fall 2014

1. b
2. d
3. a
4. c
5. c
6. a
7. a
8. a
9. c
10. a
11. a
12. a
13. c
14. c
15. b
16. e
17. a
18. c
19. a
20. a
21. a
22. c
23. e
24. c
25. a

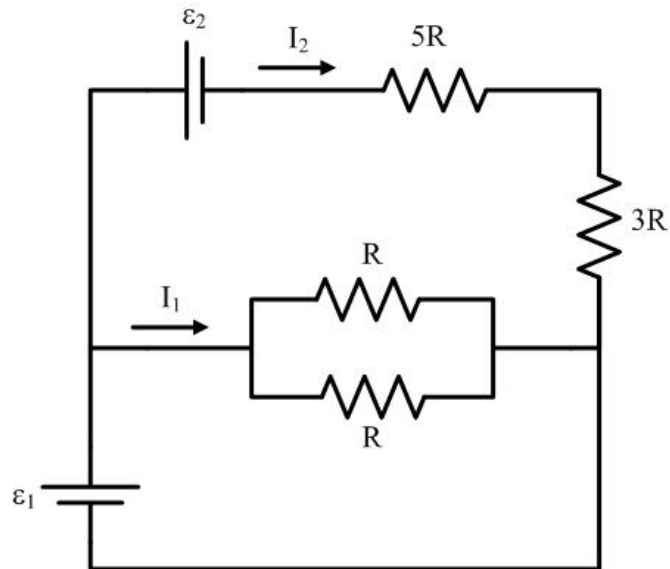

21. Which of the equations below correctly describe the circuit above?

I. $\epsilon_1 - 8I_2R - \epsilon_2 = 0$

II. $\epsilon_1 - \frac{1}{2}I_1R = 0$

III. $\epsilon_2 + 8I_2R - \frac{1}{2}I_1R = 0$

- a. I and II
- b. II and III
- c. I and III
- d. I, II and III
- e. None of the above.

The next three questions pertain to the following situation:

The switch in the circuit shown below has been open for a long time so that the capacitor is initially uncharged.

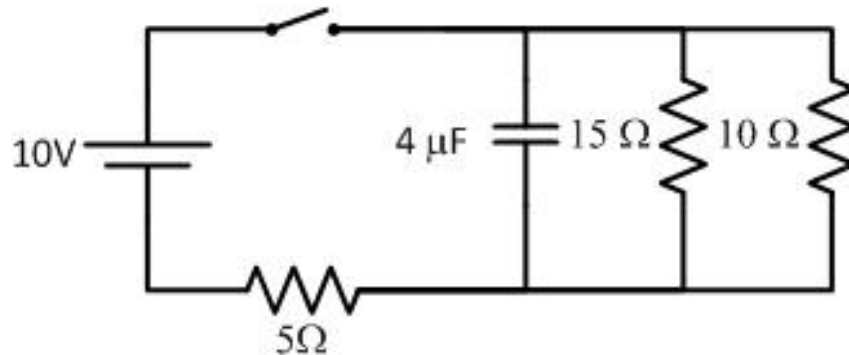

25. What is the current through the 5 Ω resistor immediately after the switch is closed?
- 2.0 A
 - 0.9 A
 - 0 A
26. What is the voltage across the capacitor after the switch has been closed for a long time?
- 4.55 V
 - 5.45 V
 - 7.5 V
 - 8.2 V
 - 10 V
27. The after the switch has been closed for a long time, it is then opened again. What is the current through the 15Ω after the switch has been open for 30μs?
- 0.260 A
 - 0.257 A
 - 0.220 A
 - 0.104 A
 - 0.156 A

**Check to make sure you bubbled in all your answers.
Did you bubble in your name, exam version and network-ID?**

KEY

Exam 1 – Fall 2011

1. c
2. b or c
3. d
4. b
5. a
6. b
7. d
8. d
9. d
10. c
11. a
12. d
13. b
14. c
15. b
16. b
17. d
18. a
19. c
20. e
21. d
22. a
23. d
24. a
25. a
26. b
27. d

The next three questions pertain to the situation described below.

Consider the circuit shown below.

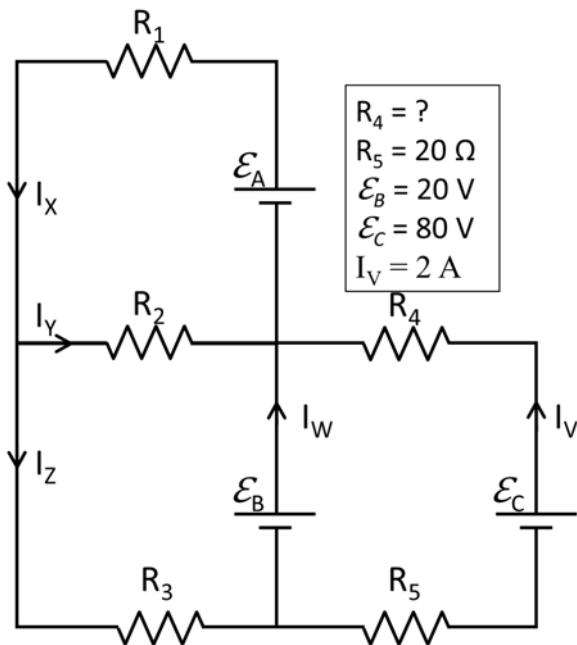

9) What is the resistance of resistor R_4 ?

- $R_4 = 5 \Omega$
- $R_4 = 10 \Omega$
- There is no value of R_4 for which $I_v = 2 \text{ A}$.
- $R_4 = 20 \Omega$
- $R_4 = 2 \Omega$

10) Which of the following equations is a valid application of Kirchhoff's current law?

- $I_x + I_y = I_z$
- $I_z = I_w - I_v$
- $I_y + I_w + I_v - I_x = 0$

11) Which of the following equations is **NOT** a valid application of Kirchhoff's voltage law?

- $\mathcal{E}_A + \mathcal{E}_B - I_x R_1 - I_z R_3 = 0$
- $\mathcal{E}_B - I_y R_2 - I_z R_3 = 0$
- $\mathcal{E}_A - I_x R_1 - I_y R_2 = 0$

The next four questions pertain to the situation described below.

Consider the circuit shown below. Initially, both switches are open and the capacitor has been charged to 10 Volts.

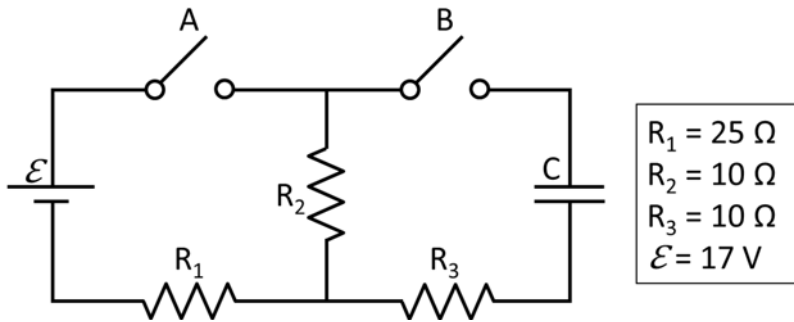

At time $t=0$ switch B is closed (switch A remains open).

12) What is the current through resistor R_3 just after the switch B is closed?

- a. $I_3 = 1.5 \text{ A}$.
- b. $I_3 = 0.5 \text{ A}$.
- c. $I_3 = 2.5 \text{ A}$.

13) Which of the following plots best represents the voltage V_2 across resistor 2 starting just after switch B is closed? (Be careful image is above answer choice)

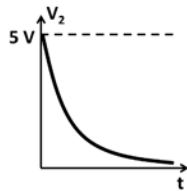

a.

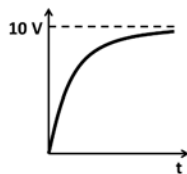

b.

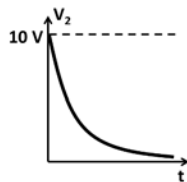

c.

14) **Figure repeated from previous page**

Consider the circuit shown below. Initially, both switches are open and the capacitor has been charged to 10 Volts. At time $t=0$ switch B is closed (switch A remains open).

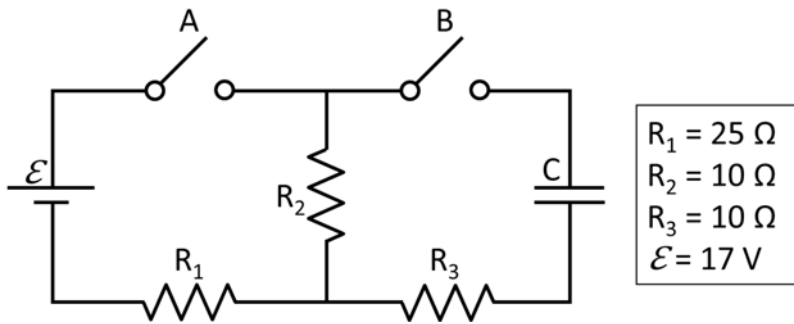

If it takes $12 \mu\text{s}$ for the charge on the capacitor to drop the 1/2 of its initial value, what is the capacitance of the capacitor C?

- a. $C = 1631 \text{ nF}$
 - b. $C = 493 \text{ nF}$
 - c. $C = 3370 \text{ nF}$
 - d. $C = 866 \text{ nF}$
 - e. $C = 215 \text{ nF}$
- 15) After a very long time, switch A is closed. Switch B remains closed. What is the magnitude of the current I_1 through resistor R_1 immediately after switch A is closed?

- a. $I_1 = 0.567 \text{ A}$
- b. $I_1 = 0.165 \text{ A}$
- c. $I_1 = 0.202 \text{ A}$
- d. $I_1 = 0.446 \text{ A}$
- e. $I_1 = 0.930 \text{ A}$

Physics 102 Exam 1 --
Spring 2014

1. d
2. a
3. c
4. c
5. e
6. c
7. b
8. c
9. b
10. c
11. b
12. b
13. a
14. d
15. a
16. cd
17. a
18. c
19. b
20. a
21. d
22. a
23. b
24. a

7. Consider the circuit below. Which of the following equations is *incorrect*?

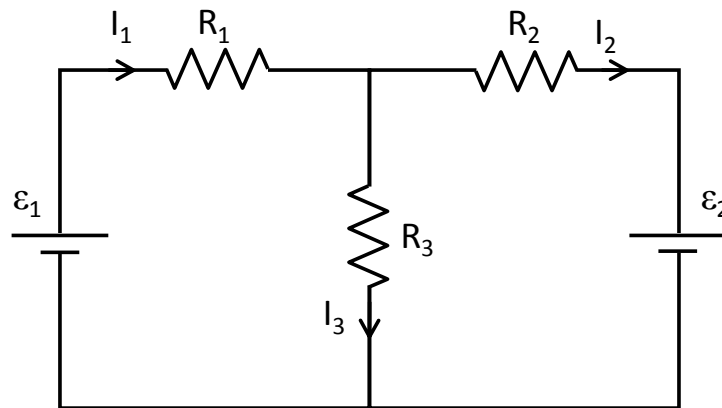

- a. $\mathcal{E}_1 - \mathcal{E}_2 - I_1 R_1 - I_2 R_2 = 0$
- b. $\mathcal{E}_1 - I_1 R_1 - I_3 R_3 = 0$
- c. $\mathcal{E}_2 - I_2 R_2 - I_3 R_3 = 0$

The next three questions pertain to the following situation:

Consider the circuit below. $\mathcal{E}_1 = 15 \text{ V}$, $\mathcal{E}_2 = 5 \text{ V}$, $R_1 = 1 \Omega$, $R_2 = 2 \Omega$.
Initially the switch S is *open*.

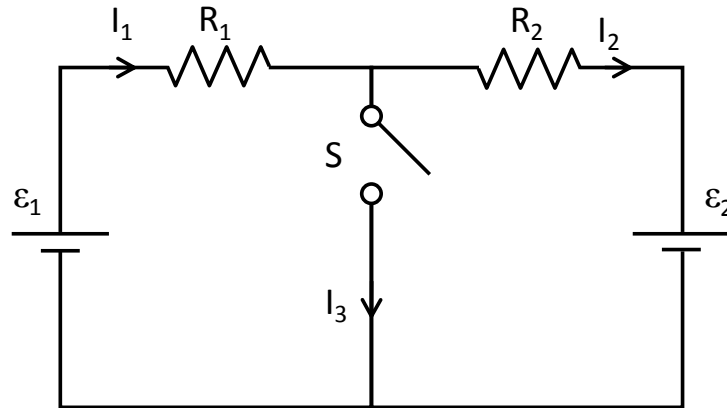

21. What is the current I_1 in resistor R_1 ?

- a. $I_1 = 0 \text{ A}$
- b. $I_1 = 6.25 \text{ A}$
- c. $I_1 = 3.33 \text{ A}$
- d. $I_1 = 1.50 \text{ A}$
- e. $I_1 = 17.5 \text{ A}$

22. Now the switch S is *closed*. What is the current I_3 ?

- a. $I_3 = 0 \text{ A}$
- b. $I_3 = 6.25 \text{ A}$
- c. $I_3 = 3.33 \text{ A}$
- d. $I_3 = 1.50 \text{ A}$
- e. $I_3 = 17.5 \text{ A}$

The next five questions pertain to the following situation:

Consider the circuit below. $\mathcal{E} = 5 \text{ V}$, $R_1 = 2 \Omega$, $R_2 = 1 \Omega$, and $C = 15 \mu\text{F}$. Initially the switch S is at position B and the capacitor C is fully discharged.

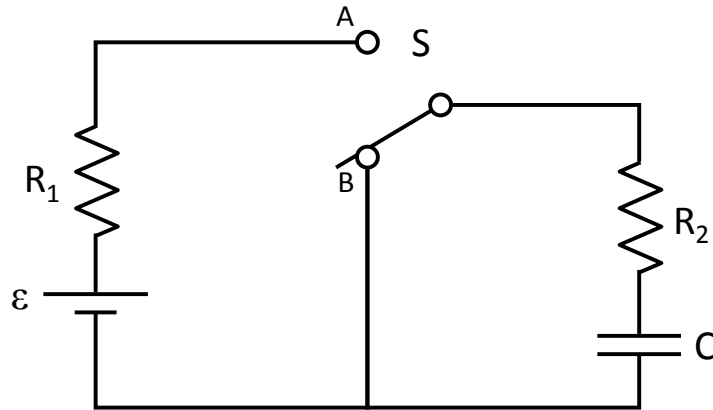

At $t = 0$, the switch S is flipped to position A.

23. What is the current I_2 in resistor R_2 *immediately* after setting the switch to A?

- a. $I_2 = 0 \text{ A}$
- b. $I_2 = 1.67 \text{ A}$
- c. $I_2 = 12.5 \text{ A}$
- d. $I_2 = 6.33 \text{ A}$
- e. $I_2 = 5.00 \text{ A}$

24. At some time $t > 0$ later, the current through R_2 is found to be $I_2 = 1.0 \text{ A}$. What is the charge Q on the capacitor C at that precise time?

- a. $Q = 30 \mu\text{C}$
- b. $Q = 250 \mu\text{C}$
- c. $Q = 75 \mu\text{C}$

The next three questions continue from the previous page:

After a long time, the switch S is reset to position B. The next three questions pertain to this situation.

25. What is the magnitude of the current I_2 in resistor R_2 *immediately* after resetting the switch to B?

- a. $I_2 = 0$ A
- b. $I_2 = 6.67$ A
- c. $I_2 = 5.00$ A
- d. $I_2 = 12.5$ A
- e. $I_2 = 1.33$ A

26. In what direction around the circuit does the current I flow immediately after resetting the switch?

- a. Clockwise
- b. Counterclockwise

27. Eventually, the current decays gradually to zero as shown in the figure below. Which formula best represents the time constant τ for this decay?

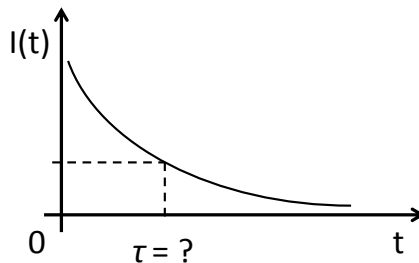

- a. $\tau = R_1C$
- b. $\tau = R_2C$
- c. $\tau = (R_1+R_2)C$

**Check to make sure you bubbled in all your answers.
Did you bubble in your name, exam version and network-ID?**

KEY

Exam 1 – Spring 2013

1. b
2. a
3. d
4. c
5. c
6. c
7. c
8. c
9. a
10. c
11. b
12. e
13. c
14. a
15. a
16. d
17. c
18. e
19. b
20. c
21. c
22. e
23. b
24. a
25. c
26. b
27. b

The following situation pertains to the next two questions:

As shown in the diagram below, a circuit is constructed consisting of two batteries with emf ϵ_1 and ϵ_2 and resistors with resistance R_1 , R_2 , and R_3 . Two currents I_1 and I_2 are labeled on the diagram.

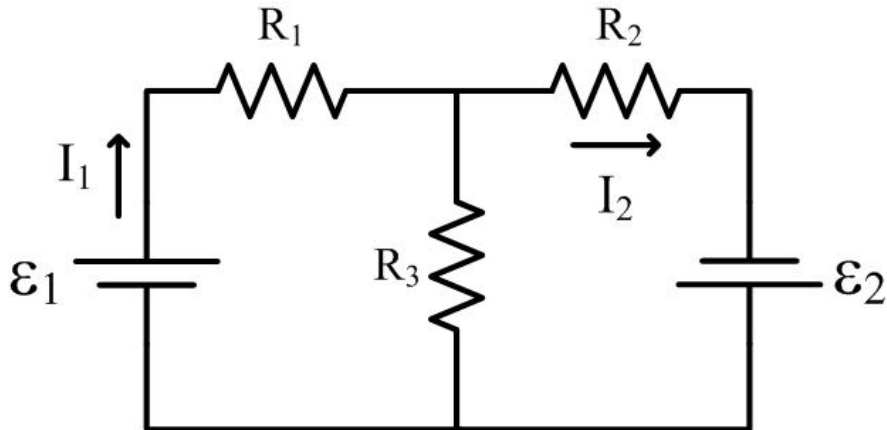

1. Which equation is a correct application of Kirchhoff's laws?

- a. $\epsilon_1 - I_1 R_1 - I_2 R_2 + \epsilon_2 = 0$
- b. $\epsilon_1 + I_1 R_1 + I_2 R_2 + \epsilon_2 = 0$
- c. $\epsilon_1 + I_1 R_1 - I_2 R_2 = 0$

2. Which equation is another correct application of Kirchhoff's laws?

- a. $\epsilon_2 - (I_1 - I_2) R_3 = 0$
- b. $\epsilon_1 - I_1 R_1 - (I_1 - I_2) R_3 = 0$
- c. $\epsilon_1 - I_1 R_1 - (I_1 + I_2) R_3 = 0$
- d. $\epsilon_2 + (I_1 - I_2) R_3 + I_2 R_2 = 0$
- e. $\epsilon_2 + (I_1 + I_2) R_3 + I_2 R_2 = 0$

The following situation pertains to the next four questions:

The circuit in the diagram below consists of a 5V battery, a $6\ \mu\text{F}$ capacitor, and a $5\ \Omega$, $20\ \Omega$, and $10\ \Omega$ resistor. The switches A and B are initially open, and the capacitor is initially uncharged.

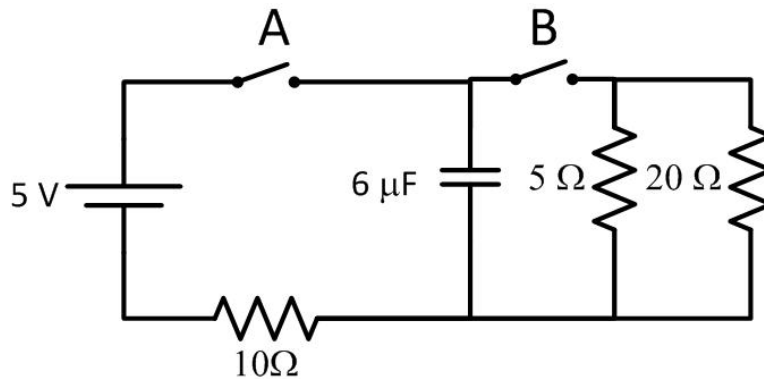

5. Switch A is closed at time $t=0$ and switch B is left open. Which graph shown below best represents how the voltage V_C across the capacitor changes with time t ?

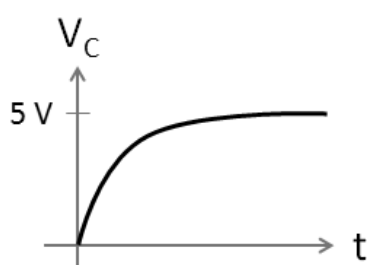

a

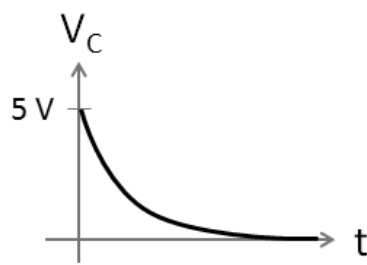

b

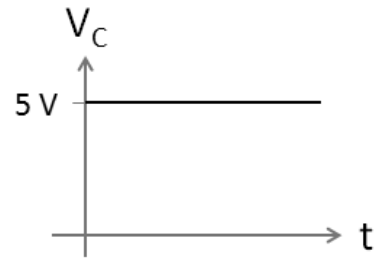

c

- a. a
- b. b
- c. c

6. After closing switch A and waiting a long time, what is the charge on the capacitor?

- a. $0\ \text{C}$
- b. $1.2\ \mu\text{C}$
- c. $30\ \mu\text{C}$

The next two questions refer to the diagram on the previous page:

7. After closing switch A and waiting a long time, what is the current through the $10\ \Omega$ resistor?

- a. $0.5\ \text{A}$
- b. $0\ \text{A}$
- c. $2\ \text{A}$

8. After switch A has been closed for a long time, switch A is opened and switch B is closed. Which graph best represents how the current I through the $5\ \Omega$ resistor changes with time after switch B is closed?

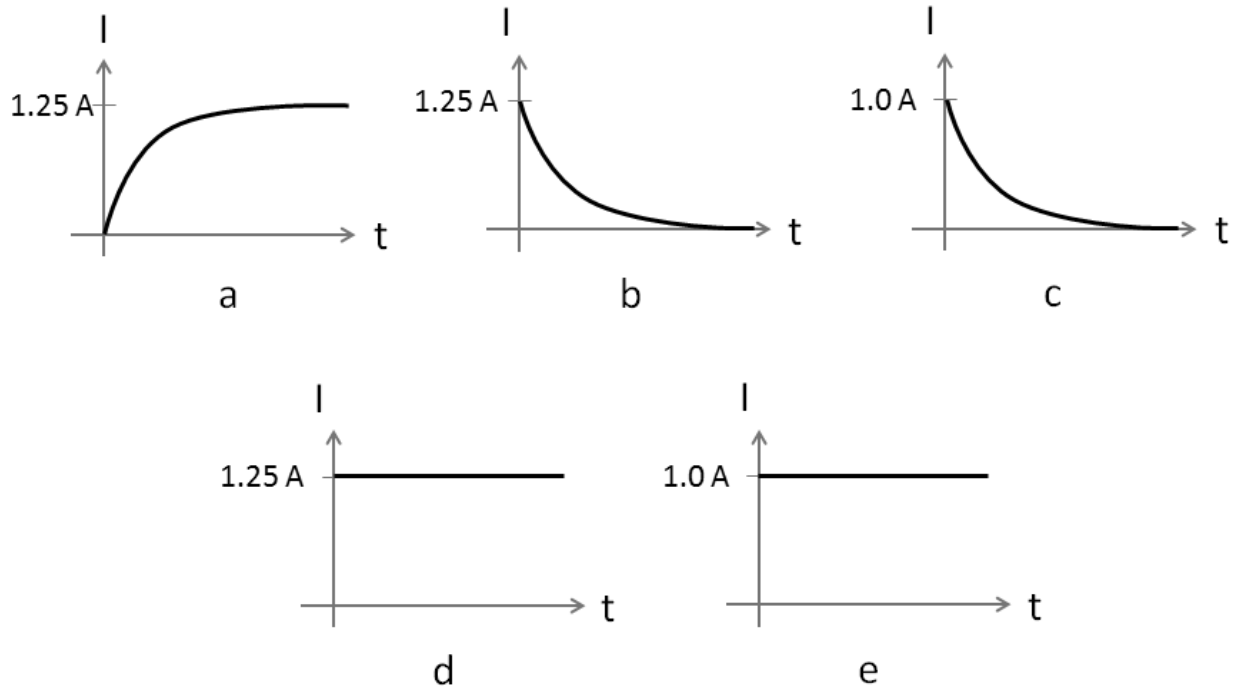

- a. a
- b. b
- c. c
- d. d
- e. e

KEY

Exam 1 – Fall 2012

1. a
2. b
3. c
4. e
5. a
6. c
7. b
8. c
9. e
10. a
11. a
12. a
13. a
14. d
15. c
16. b
17. b
18. c
19. c
20. b
21. b
22. c
23. b
24. d
25. d
26. c
27. c

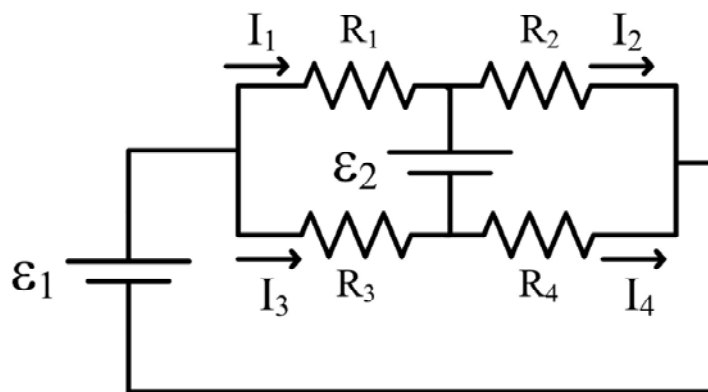

14. What is a valid Kirchhoff loop rule for the circuit shown above?

- a. $\mathcal{E}_1 + I_1 R_1 - I_2 R_2 = 0$
- b. $I_4 R_4 + I_3 R_3 - I_1 R_1 - I_2 R_2 = 0$
- c. $-\mathcal{E}_2 - I_2 R_2 + I_4 R_4 = 0$

The next two questions pertain to the circuit shown below:

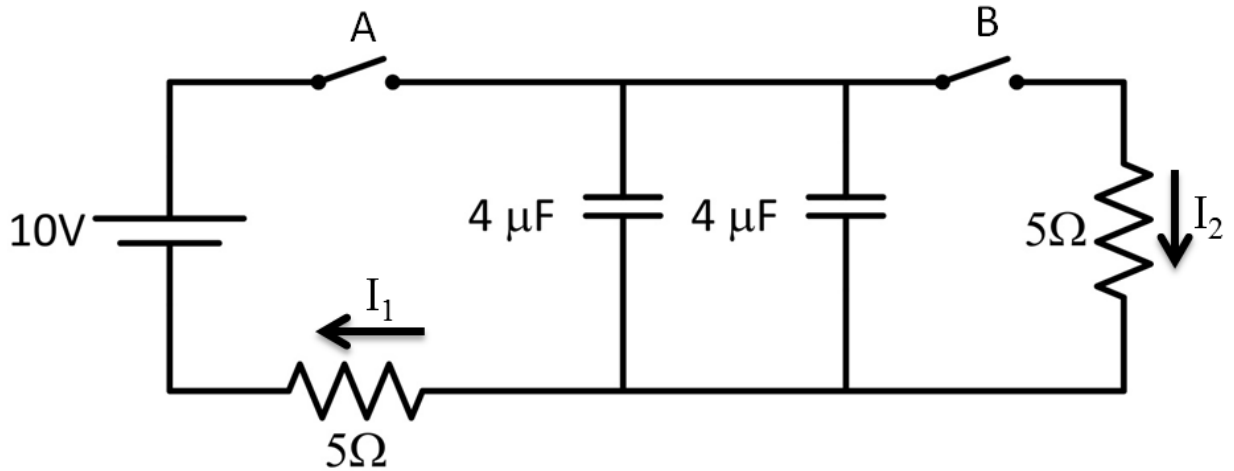

15. Switch B is opened. What is the current I_1 if switch A is left closed for a long time?

- a. 2 A
- b. 0.5 A
- c. 0 A

16. Switch B is opened and switch A is left closed for a long time. Then switch A is opened and switch B is closed. What is the current I_2 immediately after switch B is closed?

- a. 2 A
- b. 0.5 A
- c. 0 A

KEY

Exam 1 – Spring 2012

1. c
2. a
3. b
4. c
5. a
6. c
7. c
8. c
9. a
10. ae
11. d
12. a
13. b
14. b
15. c
16. a
17. b
18. abcde
19. d
20. c
21. b
22. a
23. d
24. b
25. d
26. b