

Water Flow

Or: The Modern Prometheus

Group 8

Motivation

- Curiosity
- When's the best time to get a drink?

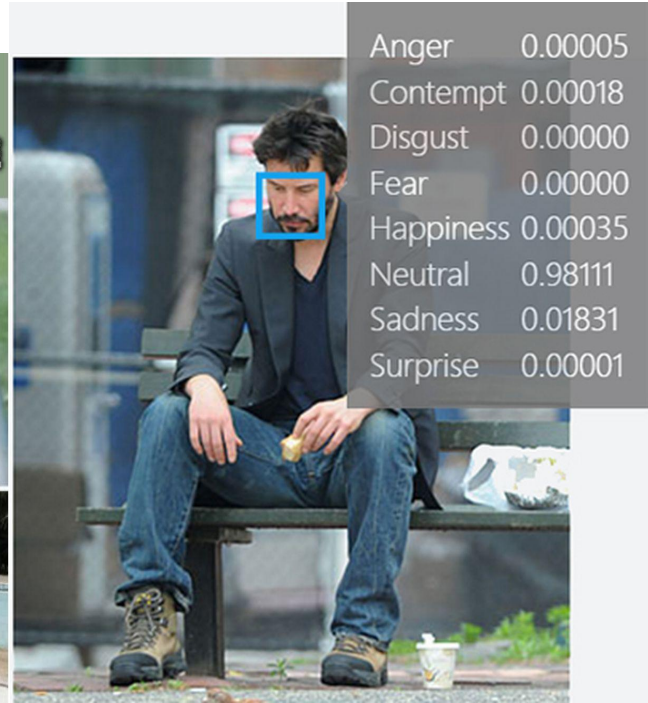

General Board Layout

BME and flow/pressure data is saved to an SD Card

Both time interval and manually triggered data acquisition

LCD for debugging and life readout

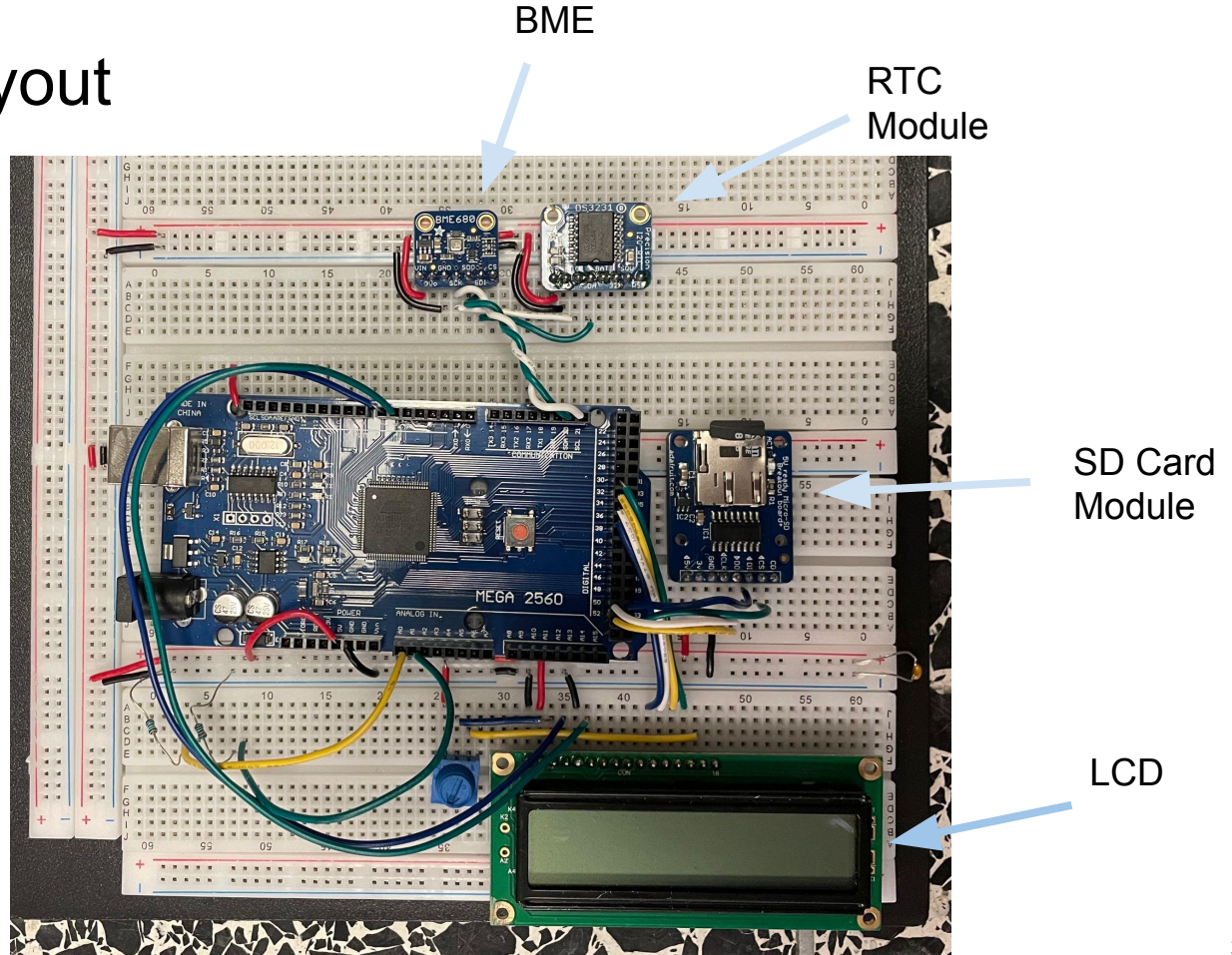

Future Layout (Tentative)

PCB Stacked on top of the mega to save space

Re-using our board across different experiments (JST pins)

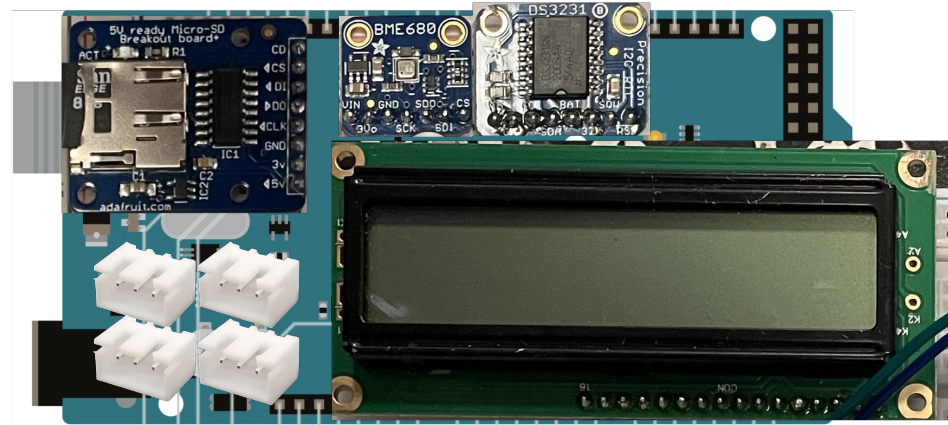

JST Pins for sensors

Flow Sensor

What is the first thing you think of when you think of measuring water flow?

Turbine Flow Sensors

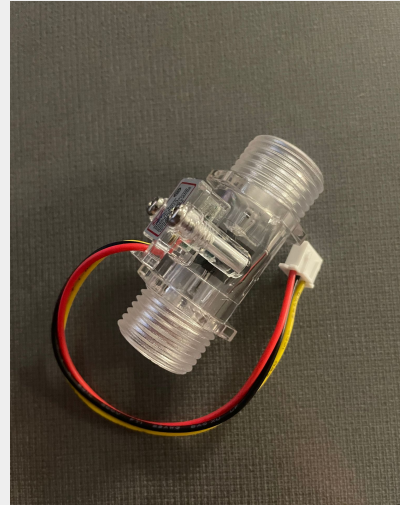

Stream Size Problem

- However these flow sensors are made so they can be installed in pipes i.e they expect the diameter of water flow to be the size of the sensor
- The stream coming from the water fountains is very inconsistent
- So it would not measure the flow rate correctly
- How do we tackle this problem

Funnel Solution

- We tried to use a funnel to solve this problem as that has a constant size
- We thought that as the funnel fills up the pressure increases and so the rate at which the water exited the funnel would become equal to the rate at which it enters which was the flow rate so the pressure would reach an equilibrium
- It did not work
- So we had a better solution



Mega Funnel

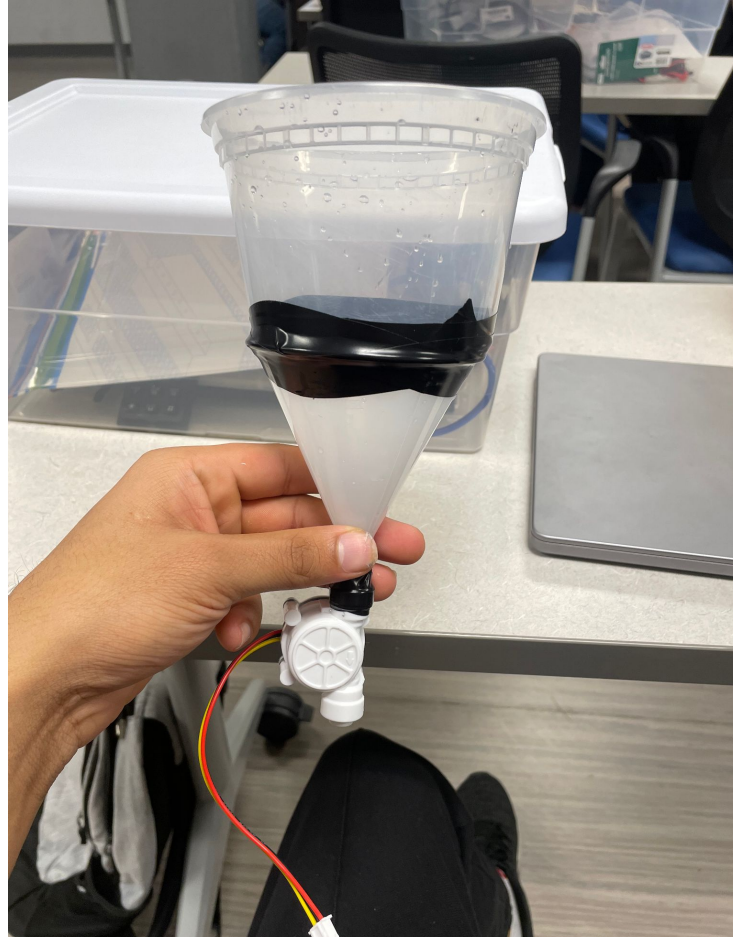

Closed Pipe Approach

- We use a vinyl pipe to connect the water flow sensor to the exit outlet of the water fountain. We use a connector to connect the exit outlet of the water fountain to the pipe
- This way all the water is forced to go in the flow sensor

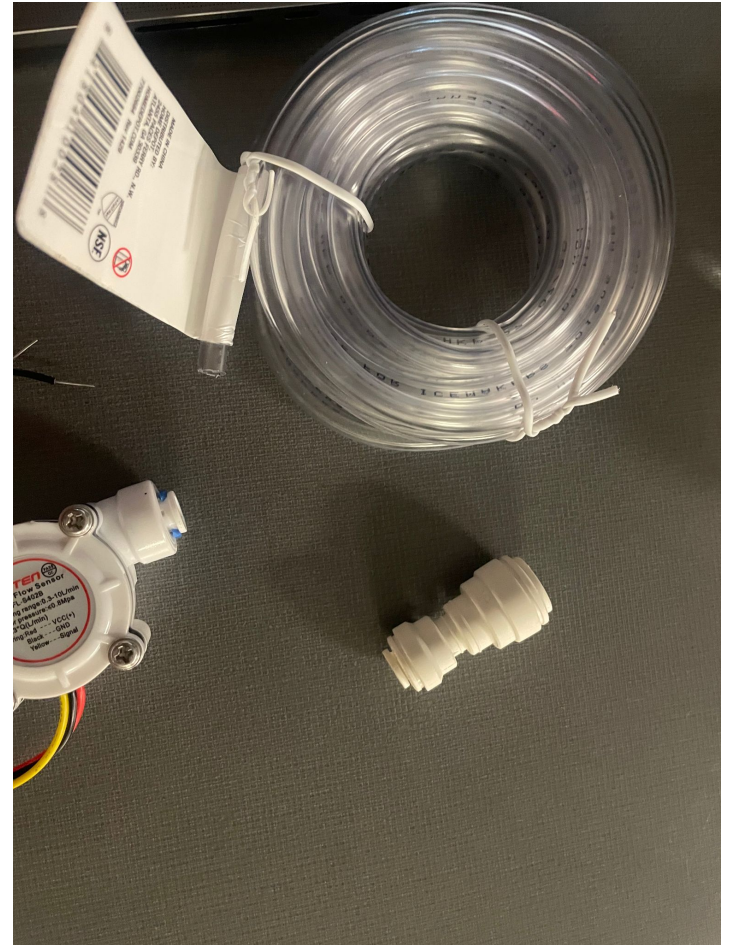

Water Flow Sensor

Red - Vcc

Black - GND

Yellow - Signal

Working Range - 0.3-10L/min

Water Pressure <800,000Pa

Diameter - 0.25 inches



```

20 */
21 */
22 #include "Adafruit_LiquidCrystal.h"
23
24 Adafruit_LiquidCrystal lcd(7, 6, 36, 34, 32, 30);
25 byte statusLed = 13;
26
27 byte sensorInterrupt = 0; // 0 = digital pin 2
28 byte sensorPin = 3;
29
30 // float volume_per_pulse = 0.00225; // This is for the 1/2"
31 float volume_per_pulse = 5.0 / 10488.0; // This is for the 1/4"
32 volatile byte pulseCount;
33 float totalVolume = 0.0;
34
35 float flowRate;
36 unsigned int flowMilliLitres;
37 unsigned long totalMilliLitres;
38
39 unsigned long oldTime;
40
41 void setup() {
42   Serial.begin(9600);
43   lcd.begin(16,2);
44   // Set up the status LED line as an output
45   pinMode(statusLed, OUTPUT);
46   digitalWrite(statusLed, HIGH); // We have an active-low LED attached
47
48   pinMode(sensorPin, INPUT);
49   digitalWrite(sensorPin, HIGH);
50
51   pulseCount = 0;
52   flowRate = 0.0;
53   flowMilliLitres = 0;
54   totalMilliLitres = 0;
55   oldTime = 0;
56
57   attachInterrupt(digitalPinToInterrupt(sensorPin), pulseCounter, FALLING);\
58 }
59
60 /**

```

```

63 void loop() {
64
65   if((millis() - oldTime) > 1000)    // Only process counters once per second
66   {
67     unsigned long currentTime = millis();
68     detachInterrupt(sensorInterrupt);
69
70     float volume = pulseCount * volume_per_pulse;
71     flowRate = 60 * 1000.0 * volume / (currentTime - oldTime);
72     totalVolume += volume;
73
74     unsigned int frac;
75
76     // Print the flow rate for this second in litres / minute
77     Serial.print("Flow rate: ");
78     Serial.print(flowRate);    // Print the integer part of the variable
79     Serial.print("L/min");
80     Serial.print("\t");        // Print tab space
81
82     // Print the cumulative total of litres flowed since starting
83     Serial.print("Output Liquid Quantity: ");
84     Serial.print(totalVolume);
85     Serial.print("L\n");
86
87     lcd.clear();
88     lcd.setCursor(0,0);
89     lcd.print(flowRate);
90     lcd.setCursor(0,1);
91     lcd.print(totalVolume);
92
93     // Reset the pulse counter so we can start incrementing again
94     pulseCount = 0;
95     oldTime = currentTime;
96     // Enable the interrupt again now that we've finished sending output
97     attachInterrupt(sensorInterrupt, pulseCounter, FALLING);
98   }
99 }
100
101 void pulseCounter() {
102   pulseCount++;
103 }

```

Volume Sensor

What is the second thing you think of when you think of measuring water flow?

Volume and time measurement

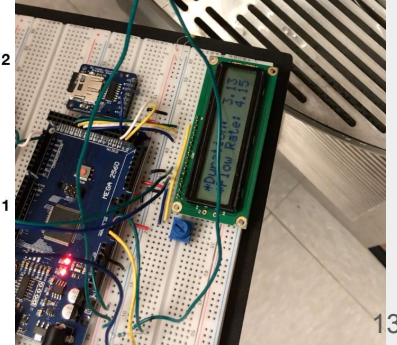
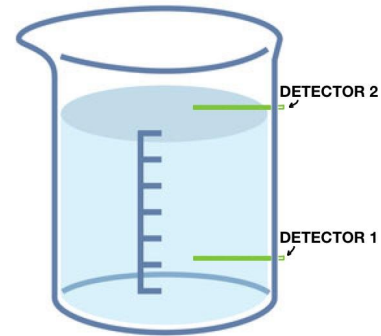
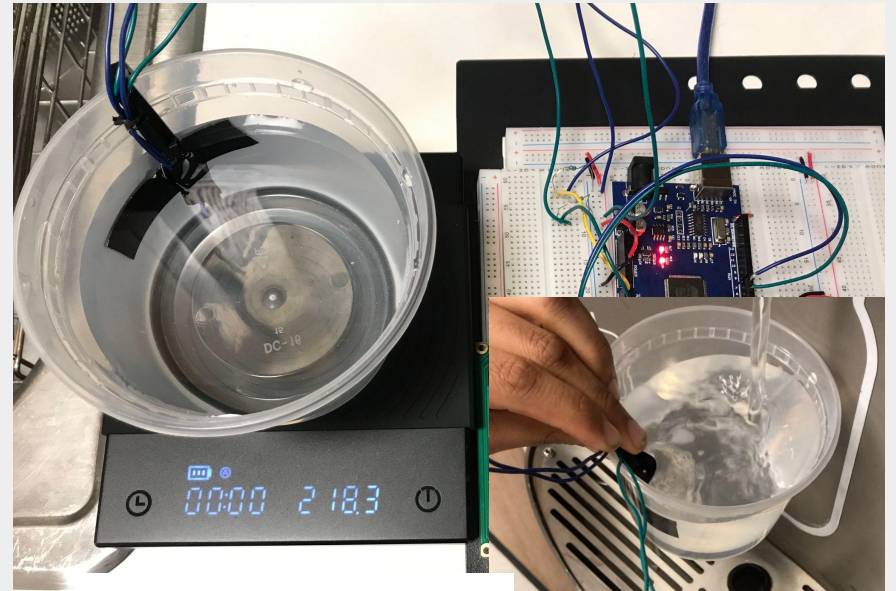

Volume Sensor

Record the time it takes for the water to travel from detector 1 to detector 2

$$\text{flow rate} = \frac{\Delta V}{\Delta t}$$

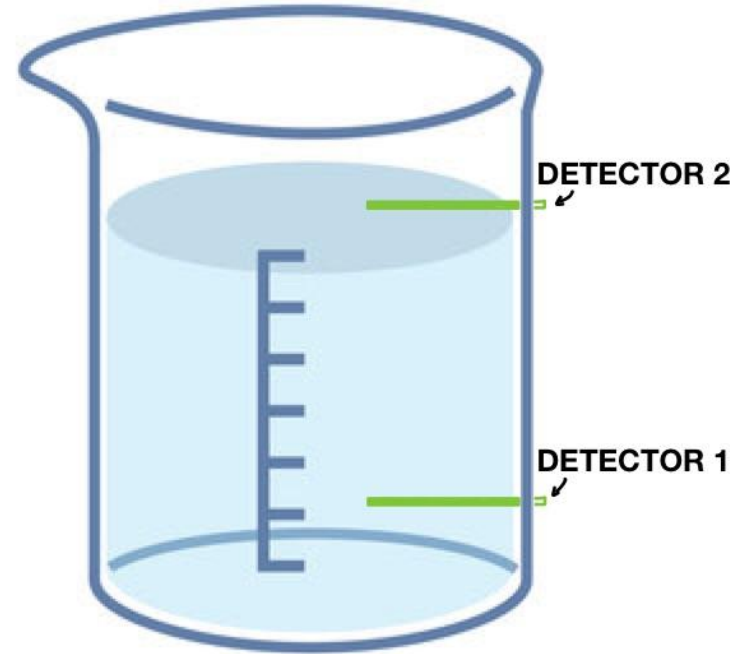

Water Sensor

When both ends of the probe are in the water, there is a resistance between them

This is read with analog in

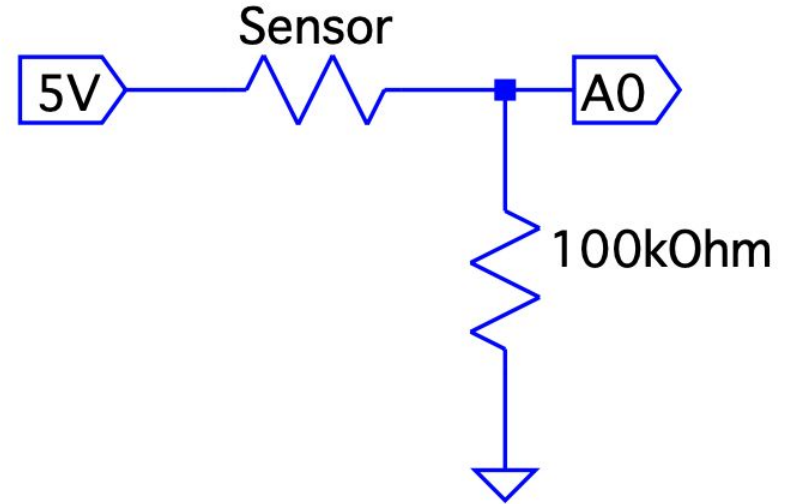

Problems

Solution:

A Pipe



Data / Code

Data is recorded every time we use it

Its small, just one number

The code registers when the first sensor is touched and then measures the time until the second one is touched and then divides the two

Pressure Sensor

What is the fifth thing you think of when you think of measuring water flow?

Pressure measurement

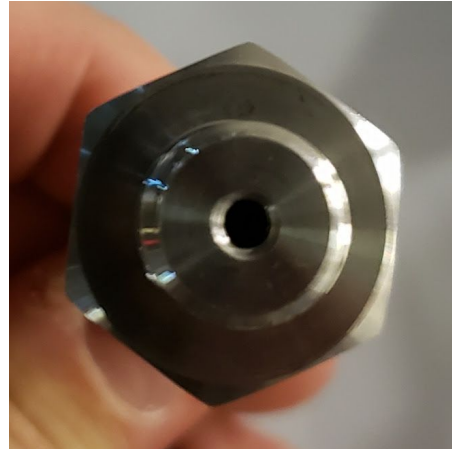

Board 2 layout

- Water pressure sensor (5V, GND, A0)
- (not pictured) SD Card
- (not pictured) RTC

- Water pressure data
- Data from the sensor are logged with timestamps on the SD card

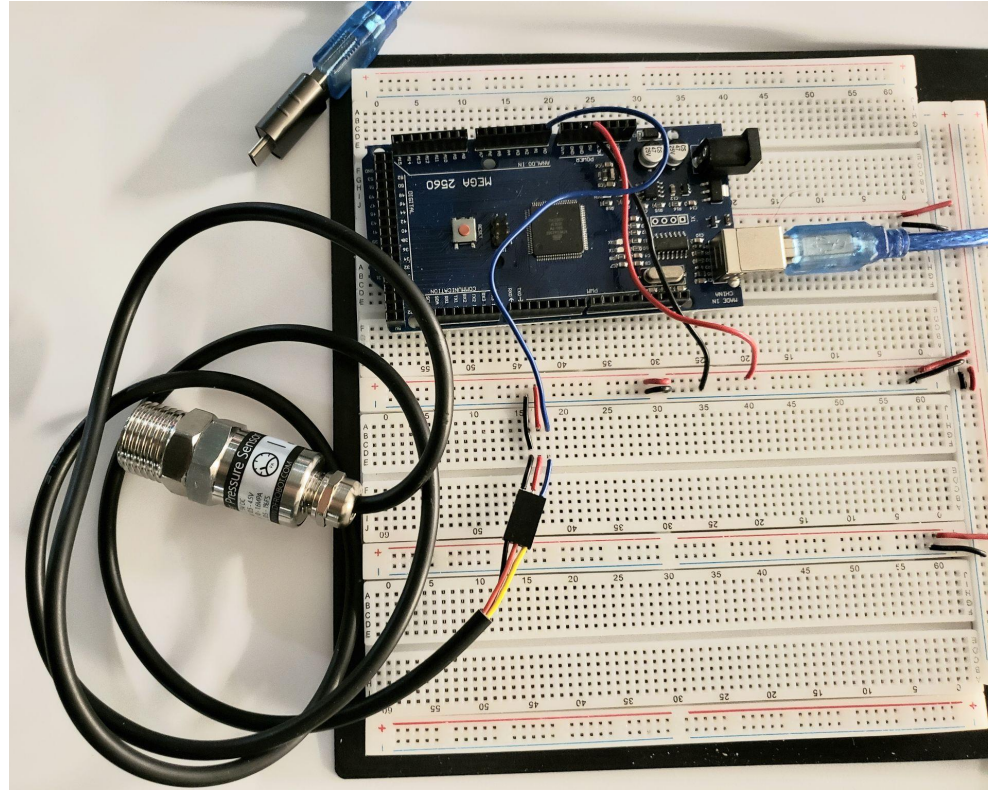

Sensor Placement

- The sensor is attached to the input hose for the water fountain
- Once installed, can be left there indefinitely
- The water fountains all have nearby outlets, so power is no concern
- Yes, we talked to the relevant authorities

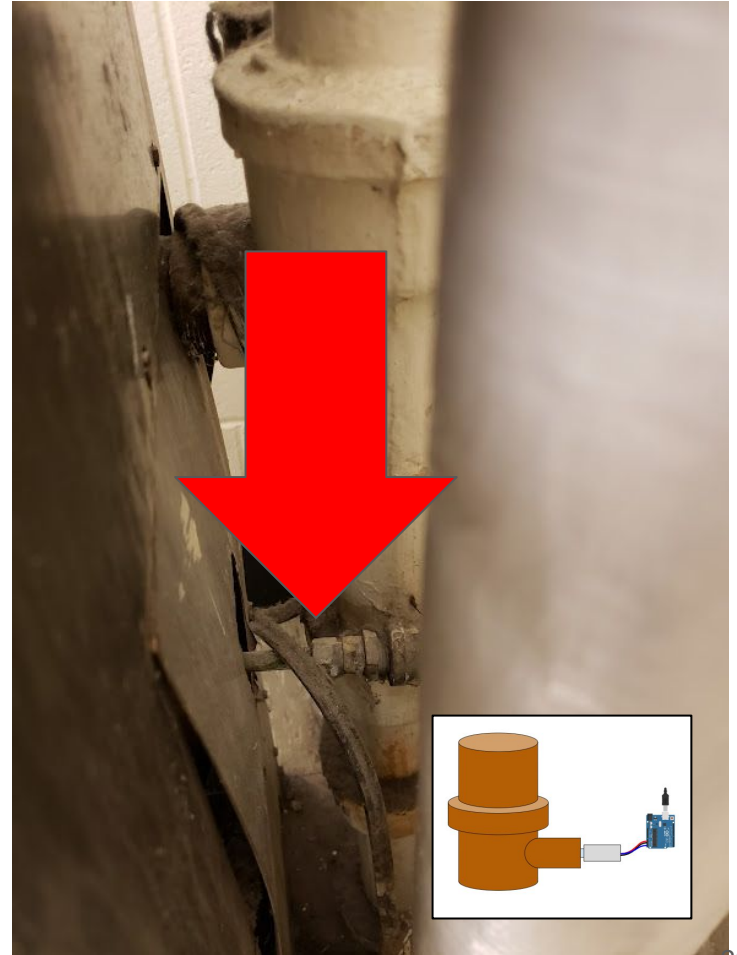

Data

- Rise and fall in water pressure throughout the day
 - Number of times the fountain is used
 - Effect of high-traffic vs. low-traffic times of day
 - Effect from the water tower
 - Can be correlated with flow sensor data
-
- Loomis does not have a pump system, so we should see a predictable decrease between floors

Data Analysis

Water Flow

Sensor gives us pulses whenever the turbine made one rotation

What we find out is the flow rate in L/min

Volume

Sensor gives us pulses when the water reaches that level

What we find out is the time taken and hence the flow rate in L/min

Pressure

Sensor tells us the water pressure

What we find out using the size of the exit outlet is the flow rate in L/min

Next Steps

- Measure the flow rate using all 3 approaches in every water fountain in Loomis
- Hopefully get consistent data
- We expect the flow rate to be consistent in the same floor and decrease in higher floors as pressure decreases