

UNIVERSITY OF ILLINOIS  
AT URBANA-CHAMPAIGN

# Basic Error Analysis

Physics 403

Eugene V Colla

D. Hertzog

A. Bezryadin



[illinois.edu](http://illinois.edu)

# Outline of the lecture

- **Errors and uncertainties**
- **The reading error**
- **Accuracy and precession**
- **Systematic and statistical errors**
- **Fitting errors**
- **Presentation of the results**



# Introduction

- Uncertainties exist in all experiments
- The final goal of any experiment is to obtain *reproducible* results. Knowing errors and uncertainties is an essential part for ensuring reproducibility.
- To know the uncertainties we use two approaches:
  - (1) Repeat each measurement many times and determine how well the result reproduces itself. If the results are different then there are **statistical errors**.
  - (2) Measure the quantity of interest using a different method. The results, if correct, are independent of the measurement technique. If the results are different then there are **systematic errors** in one of the methods or in both.
  - (3) **Presenting the result of your experiment: Use the right number of significant digits, in agreement with the estimated uncertainty.**



# Errors (uncertainties)

Result of measurement

Systematic error

$$X_{\text{meas}} = X_{\text{true}} + e_s + e_r$$

Correct value

Random error

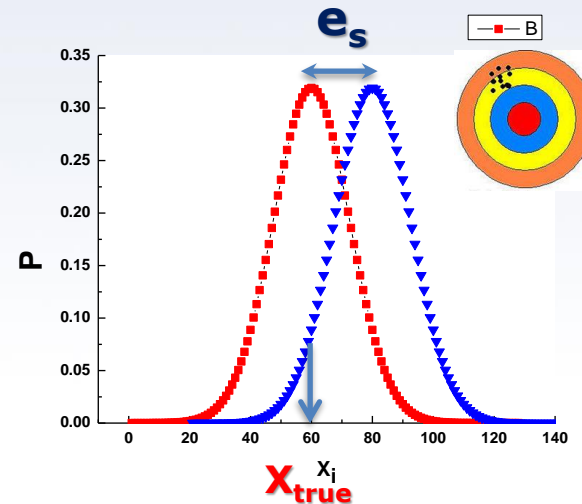
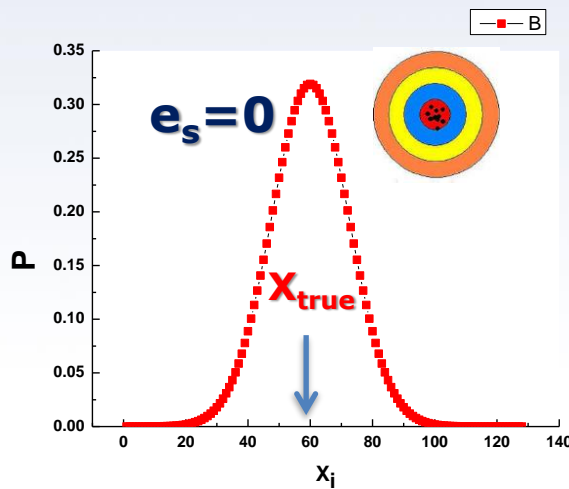

Probability distribution of the measured value



# Systematic vs. Statistical Uncertainties

- Systematic uncertainty
  - Uncertainties associated with imperfect knowledge of measurement **apparatus**, other physical **quantities** needed for the measurement, or the physical **model** used to interpret the data.
  - Generally correlated between measurements. Cannot be reduced by multiple measurements.
  - Better calibration, or measurements employing different techniques or methods can reduce the uncertainty.
- Statistical Uncertainty
  - Uncertainties due to stochastic fluctuations of molecules and photons and vibrations etc.
  - Generally there is no correlation between successive measurements.
  - Multiple measurements can be used to reduce this uncertainty.



## Example of Systematic Error

- For example, if your measuring tape has been stretched out, your results will always be lower than the true value. Similarly, if you're using scales that haven't been set to zero beforehand, there will be a systematic error resulting from the mistake in the calibration. **Such errors cannot be reduced simply by repeating the measurement and averaging the results. Such errors can be reduced by analyzing the instrument(s) used for the measurement and by using different instruments.**



# Example: Systematic errors in electrical measurements

**Sources of systematic errors: poor calibration of the equipment, changes of environmental conditions, imperfect method of observation, drift and some offset in readings etc.**

## Example #1: measuring of the DC voltage

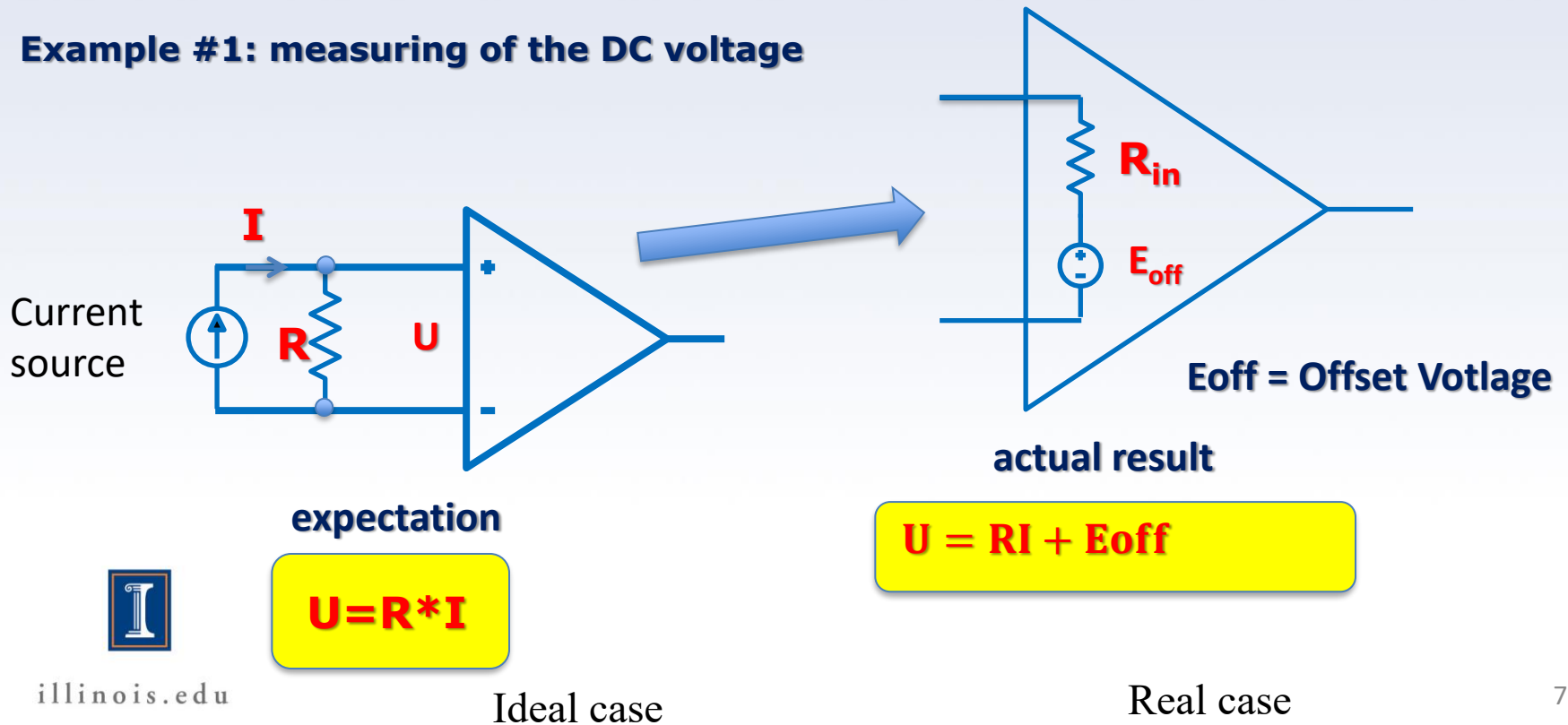

# Example: Systematic errors in temperature measurements

## Example #3: poor calibration

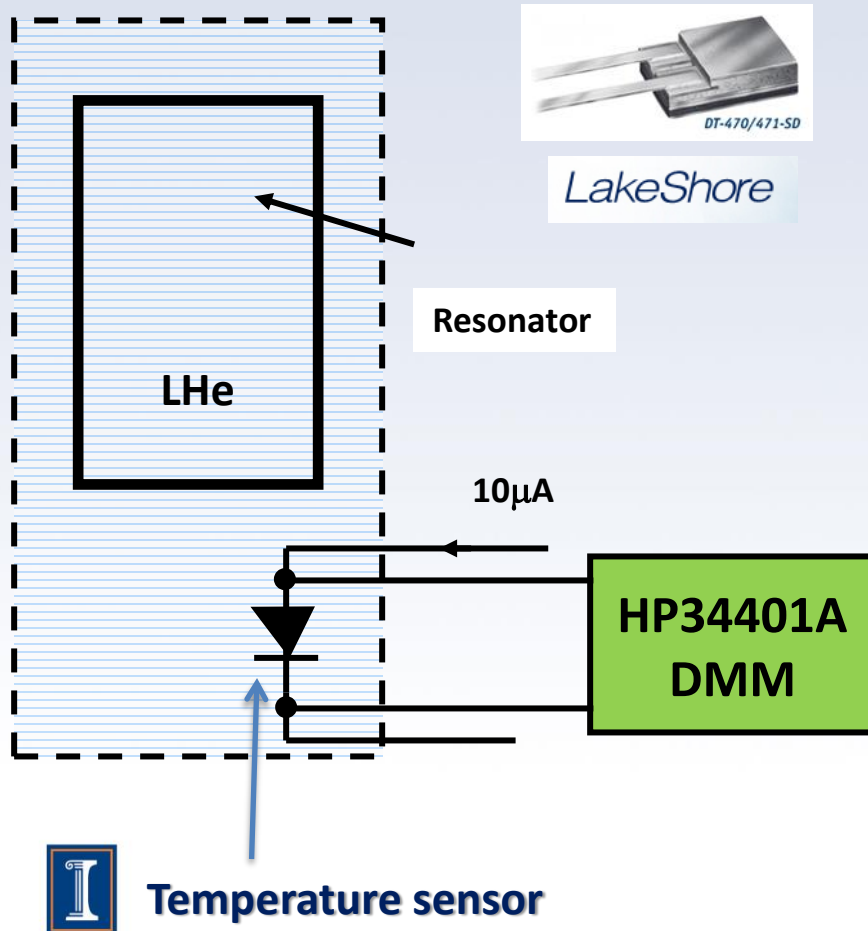

## Measuring of the speed of the second sound in superfluid He4

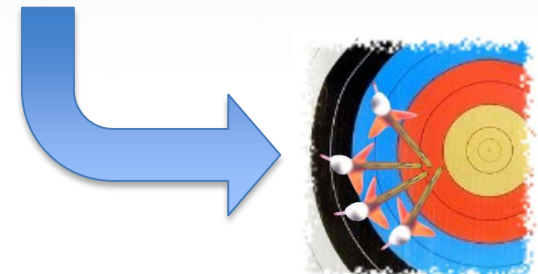
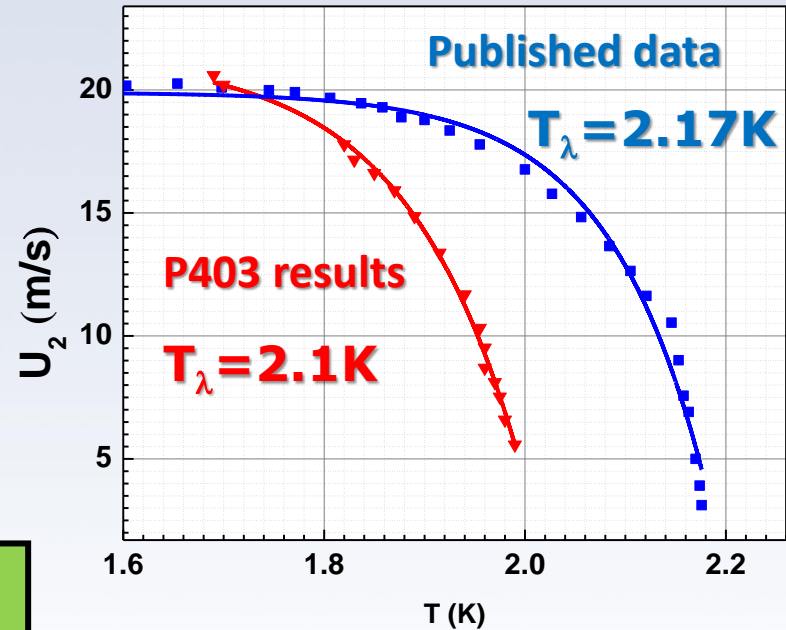



# Definitions (NIST)

The standard uncertainty  $\sigma$  of a measurement result  $x$  is the estimated standard deviation of  $x$ .

The relative standard uncertainty  $\sigma_r$  of a measurement result  $x$  is defined by  $\sigma_r = \sigma / |x|$ , where  $x$  is not equal to 0.

In statistics, the standard deviation (**SD, also represented by the Greek letter sigma  $\sigma$** ) is a measure that is used to quantify the amount of variation or dispersion of a set of data values. *A low standard deviation indicates that the data points tend to be close to the mean value of the set ( $\mu = \langle x_i \rangle$ ), while a high standard deviation indicates that the data points are spread out over a wider range of values.*

$$\sigma = \sqrt{\frac{1}{N} \sum_{i=1}^N (x_i - \mu)^2}, \quad \text{where } \mu = \frac{1}{N} \sum_{i=1}^N x_i$$



# Meaning

Meaning of uncertainty:

Assume the distribution of the measurement results is normal (Gaussian).

If the result of a measurement is  $\mathbf{x}$ , and the standard deviation is  $\sigma$ , then the interval  $\mathbf{x} - \sigma$  to  $\mathbf{x} + \sigma$  is expected to encompass approximately 68 % of the measurement results (if the measurement is repeated again and again).

Let us  $\mathbf{X}$  is the true value (never known exactly) and  $\mathbf{x}$  is the measured value. The probability that the true value  $\mathbf{X}$  is greater than  $\mathbf{x} - \sigma$ , and is less than  $\mathbf{x} + \sigma$  is estimated as 68%.

This statement is commonly written as  $\mathbf{X} = \mathbf{x} \pm \sigma$ .



# Normal (Gaussian) distribution

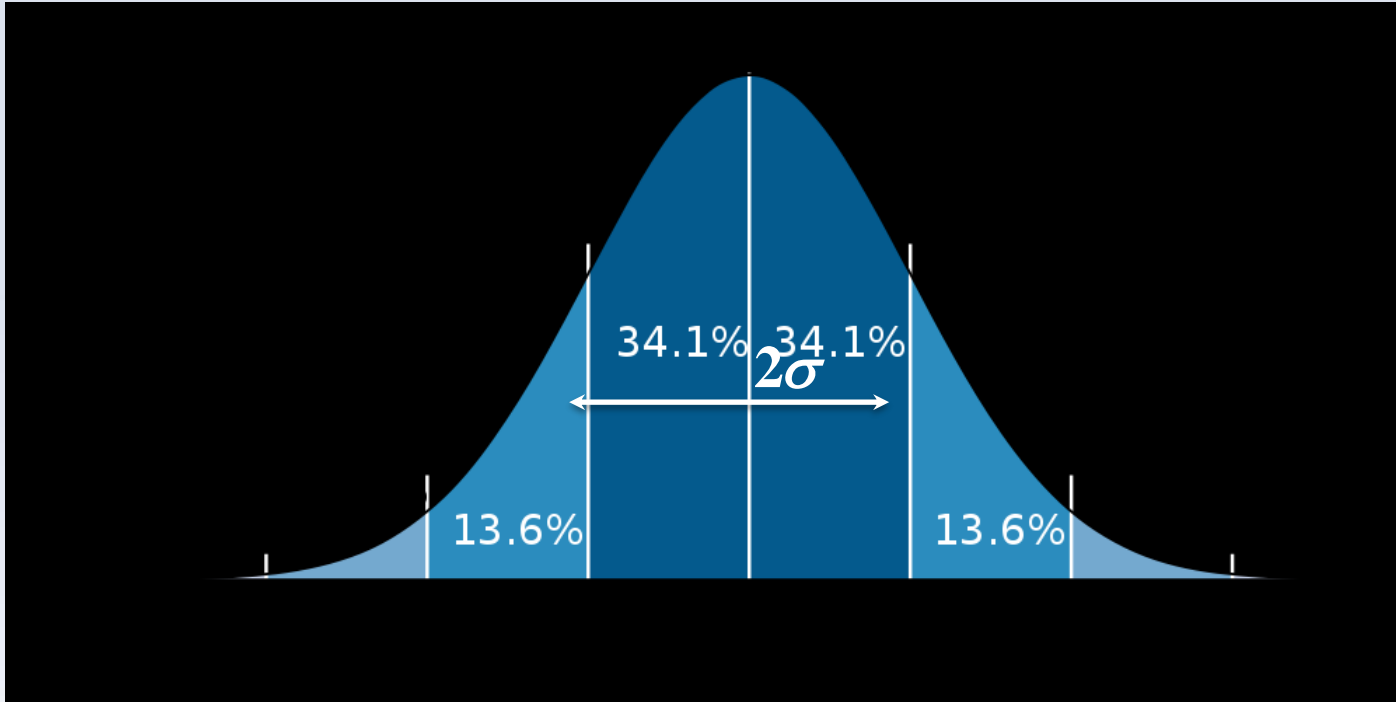

$$P_n(x) = \frac{1}{\sigma\sqrt{2\pi}} e^{-\frac{(x-\bar{x})^2}{2\sigma^2}}$$

The interval representing two standard deviations contains 95.4% of all possible true values.

Confidence interval  $\langle x \rangle \pm 3\sigma$  contains 99.7% of possible outcomes.



# Notations

Use of concise notation:

If, for example,  $v = 1\,234.567\,89\text{ m/s}$  and  $\Delta v = 0.000\,11\text{ m/s}$ , where  $\text{m/s}$  is the unit of  $v$ , then  $v = (1\,234.567\,89 \pm 0.000\,11)\text{ m/s}$ .

A more concise form of this expression, and one that is used sometimes, is  $v = 1\,234.567\,89(11)\text{ m/s}$ , where it is understood that the number in parentheses is the numerical value of the standard uncertainty referred to the corresponding last digits of the quoted result.

Examples of results which do not make sense (too many digits):

$$v = (1234.5678934534940945 \pm 0.011)\text{ m/s}$$

$$\text{or } v = (1234.56 \pm 0.01)\text{ m/s}$$



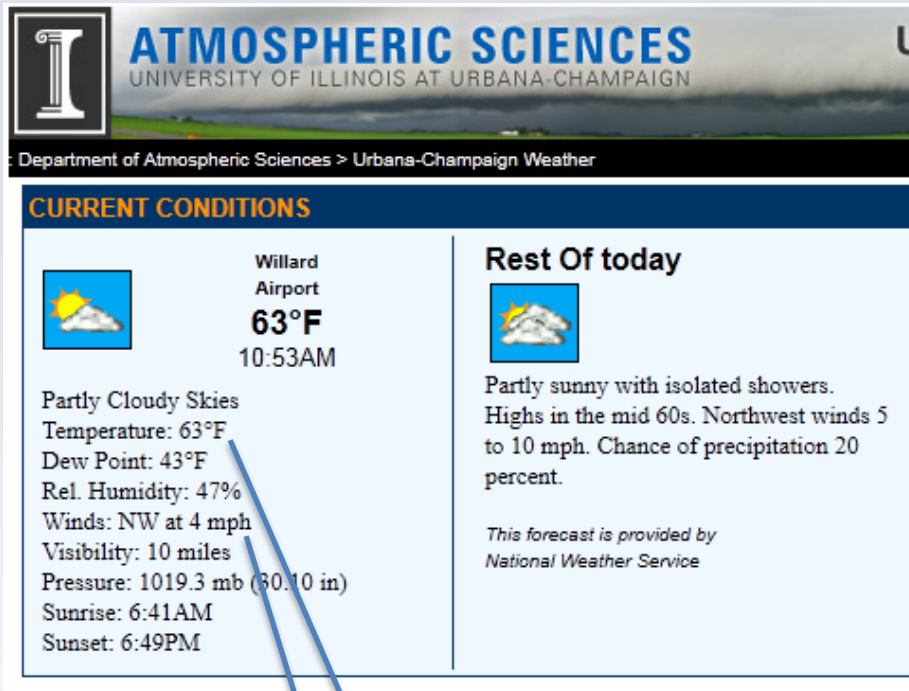

# Significant digits



**ATMOSPHERIC SCIENCES**  
UNIVERSITY OF ILLINOIS AT URBANA-CHAMPAIGN

Department of Atmospheric Sciences > Urbana-Champaign Weather

### CURRENT CONDITIONS

 Willard Airport <b>63°F</b> 10:53AM Partly Cloudy Skies Temperature: 63°F Dew Point: 43°F Rel. Humidity: 47% Winds: NW at 4 mph Visibility: 10 miles Pressure: 1019.3 mb (30.10 in) Sunrise: 6:41AM Sunset: 6:49PM	<b>Rest Of today</b>  Partly sunny with isolated showers. Highs in the mid 60s. Northwest winds 5 to 10 mph. Chance of precipitation 20 percent.  <i>This forecast is provided by National Weather Service</i>
---	--



$T = 63^{\circ}\text{F} \pm ?$   $\longrightarrow$  Best guess  $\Delta T \sim 0.5^{\circ}\text{F}$

Wind speed  $4\text{mph} \pm ?$   $\longrightarrow$  Best guess  $\pm 0.5\text{mph}$

If they say  $T=63.32456\text{ F}$ , that would be wrong since it is not possible to predict or even measure the temperature at our campus with such high precision.



# It is important to know uncertainties in science

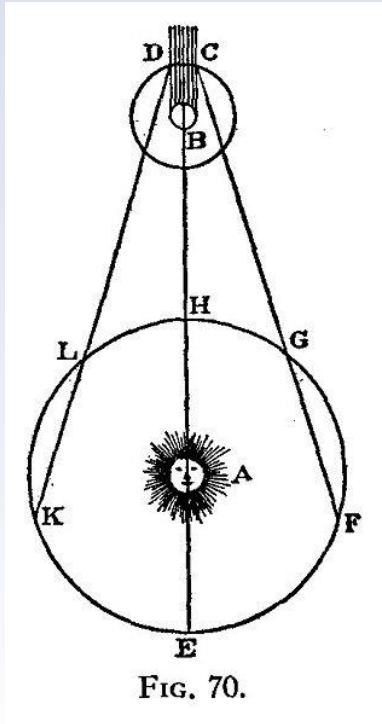

Measurement of the speed of the light

1675 Ole Roemer: 220,000 km/s



Ole Christensen Rømer  
1644-1710

Does it make sense?  
What is missing?

Maxwell's theory prediction:

The speed of light does not depend on the light wavelength, frequency or color. It is a universal constant.



NIST Bolder Colorado  $c = 299,792,456.2 \pm 1.1$  m/s.

# Reading error

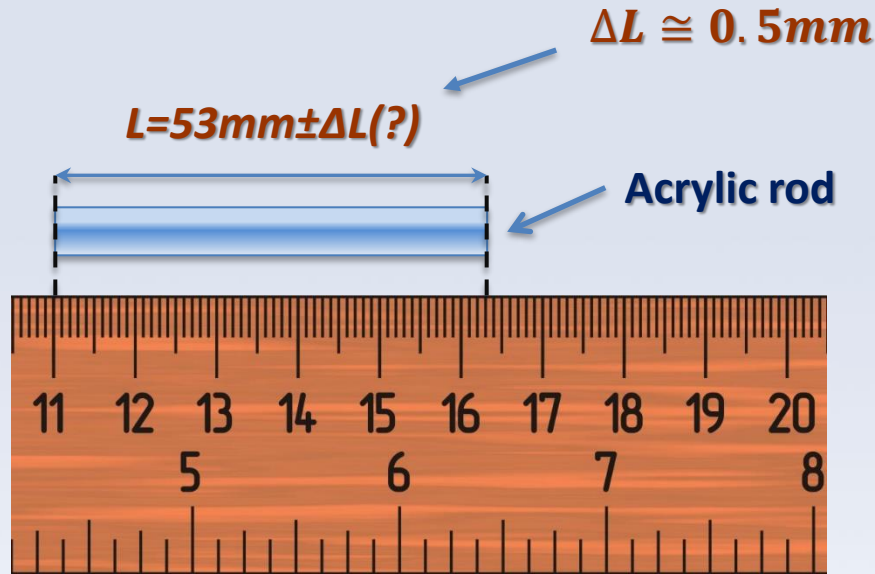

How far we have to go in reducing the reading error?

Use a simple ruler if you do not care about accuracy better than 1mm

Otherwise you need to use digital calipers

Probably the natural limit of accuracy can be due to length uncertainty because of temperature expansion. For 53mm  $\Delta L \cong 0.012\text{mm}/K$



Reading Error =  $\pm \frac{1}{2}$  (least count or minimum gradation).

# Reading error. Digital meters.



Fluke 8845A multimeter

Example Vdc (reading)=0.85V

$\Delta V$

$$= 0.85 \times (1.8 \times 10^{-5}) + 1 \times (6 \times 10^{-6}) \sim 20 \mu\text{V}$$

## 8846A Accuracy

Accuracy is given as  $\pm$  (% measurement + % of range)

Range	24 Hour (23 $\pm$ 1 $^{\circ}$ C)	90 Days (23 $\pm$ 5 $^{\circ}$ C)	1 Year (23 $\pm$ 5 $^{\circ}$ C)	Temperature Coefficient/ $^{\circ}$ C Outside 18 to 28 $^{\circ}$ C
100 mV	0.0025 + 0.003	0.0025 + 0.0035	0.0037 + 0.0035	0.0005 + 0.0005
1 V	0.0018 + 0.0006	0.0018 + 0.0007	0.0025 + 0.0007	0.0005 + 0.0001
10 V	0.0013 + 0.0004	0.0018 + 0.0005	0.0024 + 0.0005	0.0005 + 0.0001
100 V	0.0018 + 0.0006	0.0027 + 0.0006	0.0038 + 0.0006	0.0005 + 0.0001
1000 V	0.0018 + 0.0006	0.0031 + 0.001	0.0041 + 0.001	0.0005 + 0.0001





# Accuracy and precision



**The accuracy of an experiment is a measure of how close the result of the experiment comes to the true value**



**Precision refers to how closely individual measurements agree with each other**



# Accuracy and precision

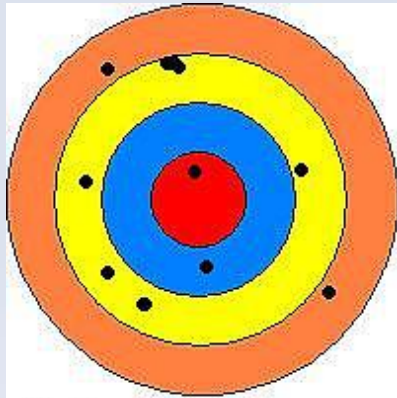

Not Precise, Not Accurate

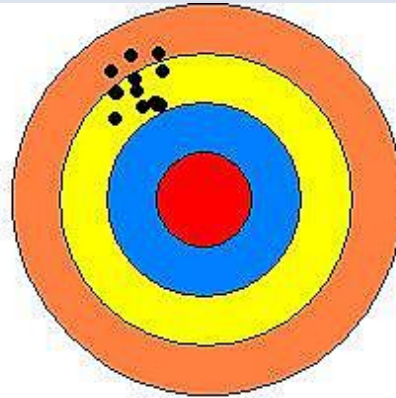

Precise, Not Accurate

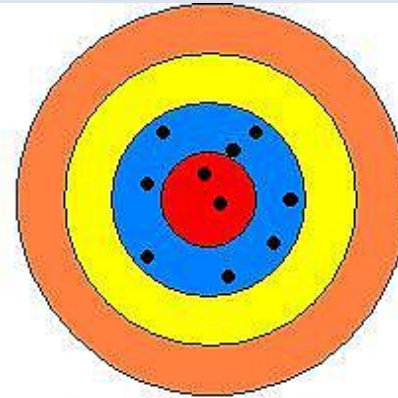

Accurate, Not Precise

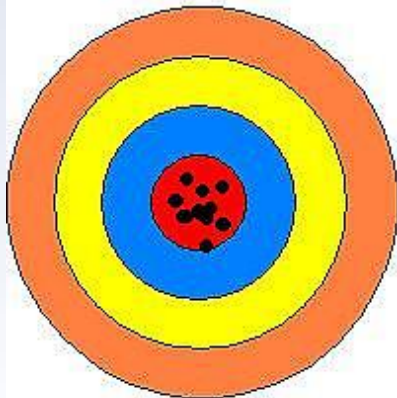

Accurate, Precise

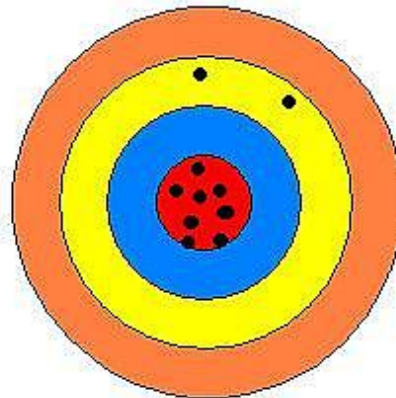

Errors



# Random errors. Poisson distribution



Siméon Denis Poisson  
(1781-1840)

$$P_n(t) = \frac{(rt)^n}{n!} e^{-rt} \quad n = 0, 1, 2, \dots$$

$r$ : decay rate [counts/s]  $t$ : time interval [s]

→  $P_n(rt)$  : Probability to have  $n$  decays in time interval  $t$

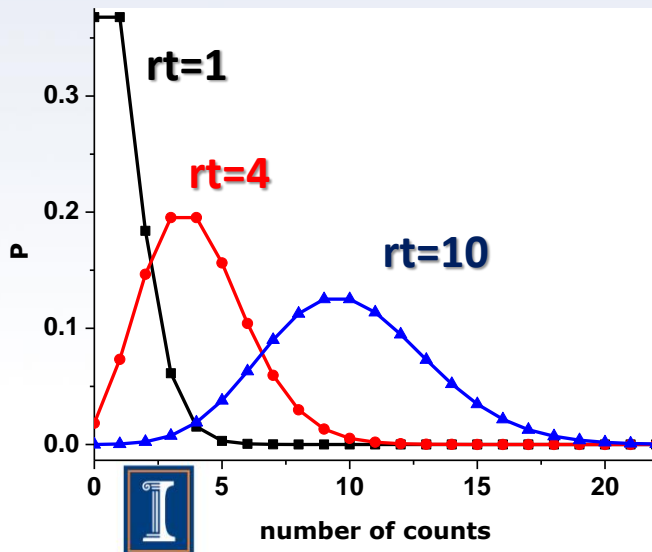

**A statistical process is described through a Poisson Distribution if:**

- **random process** → for a given nucleus probability for a decay to occur is the same in each time interval.
- **universal probability** → the probability to decay in a given time interval is same for all nuclei.
- **no correlation between two instances** (the decay of one nucleus does not change the probability for a second nucleus to decay.)

# Poisson distribution

$$P_n(t) = \frac{(rt)^n}{n!} e^{-rt} \quad n = 0, 1, 2, \dots$$

**r**: decay rate [counts/s] **t**: time interval [s]  
 →  $P_n(rt)$ : Probability to have n decays in time interval **t**

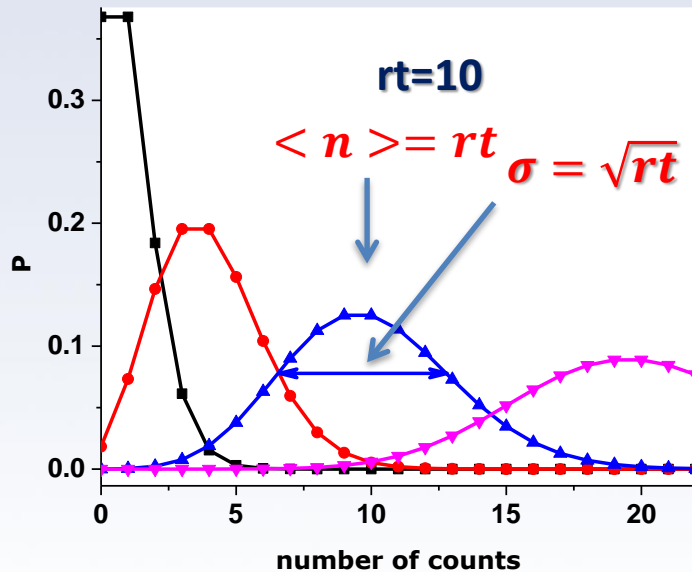

## Properties of the Poisson distribution:

$$\sum_{n=0}^{\infty} P_n(rt) = 1, \text{ probabilities sum to 1}$$

$$\langle n \rangle = \sum_{n=0}^{\infty} n \cdot P_n(rt) = rt, \text{ the mean}$$

$$\sigma = \sqrt{\sum_{n=0}^{\infty} (n - \langle n \rangle)^2 P_n(rt)} = \sqrt{rt} = \sqrt{n}, \text{ standard deviation}$$



# Poisson distribution at large $rt$

$$P_n(t) = \frac{(rt)^n}{n!} e^{-rt} \quad n = 0, 1, 2, \dots$$



**Carl Friedrich Gauss  
(1777–1855)**

## Poisson and Gaussian distributions

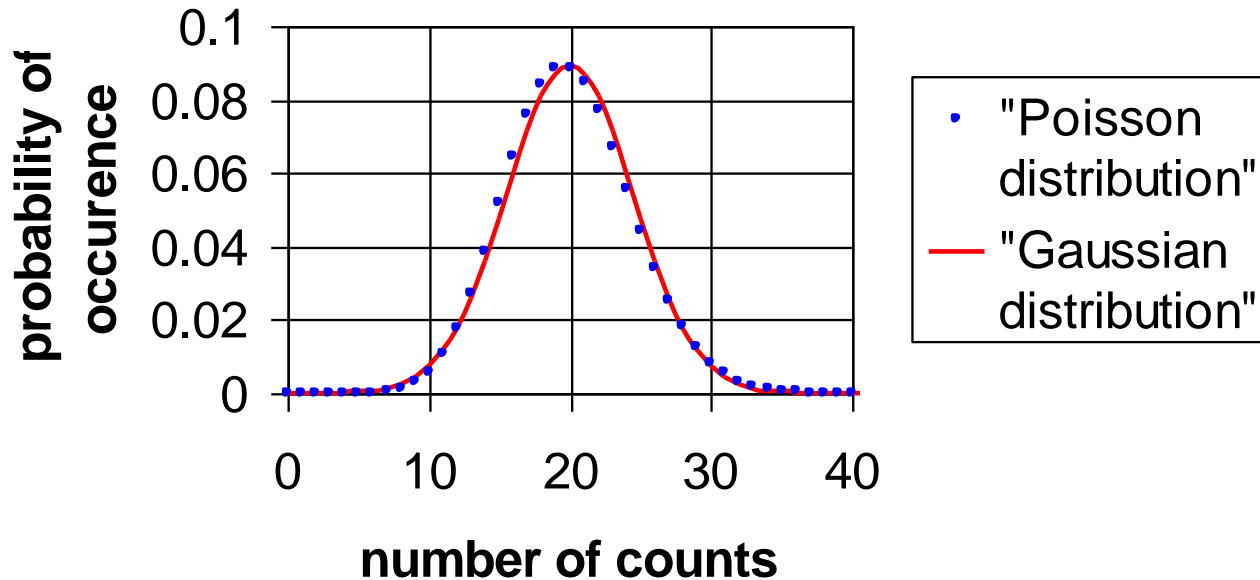

$$P_n(x) = \frac{1}{\sigma\sqrt{2\pi}} e^{-\frac{(x-\bar{x})^2}{2\sigma^2}}$$

**Gaussian distribution:  
continuous**

# Measurement in presence of noise: perform averaging to reduce the standard error

Source of noisy signal

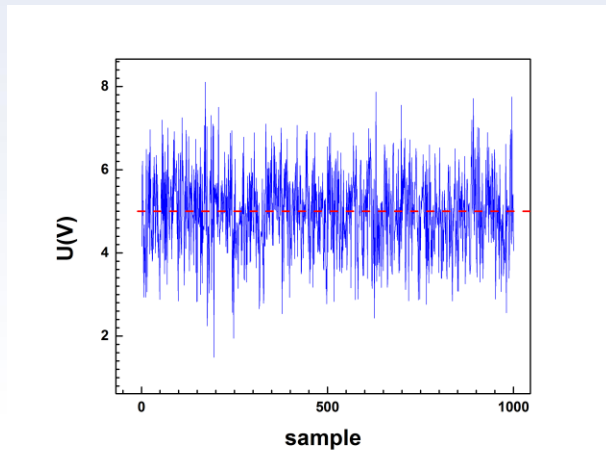
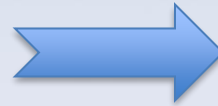

4.89855  
5.25111  
2.93382  
4.31753  
4.67903  
3.52626  
4.12001  
2.93411

**Expected value 5V**



**Actual measured values**



# Measurement in presence of noise

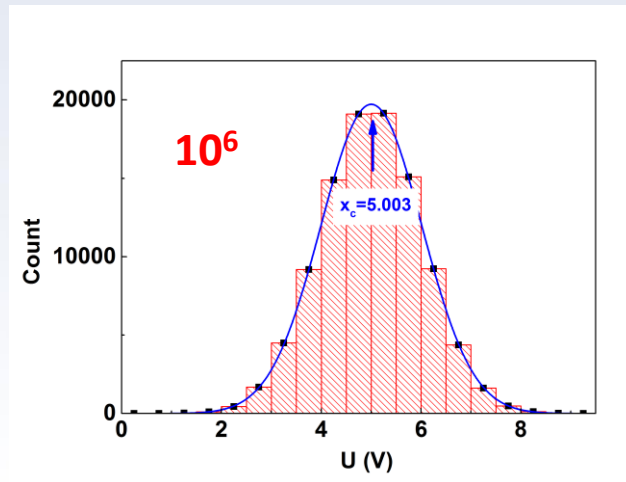
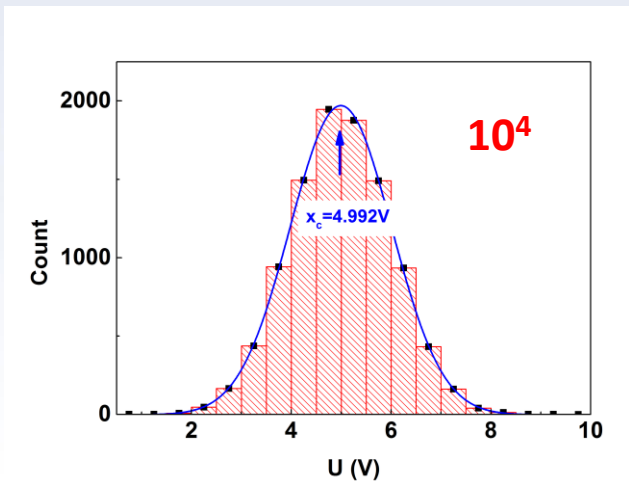
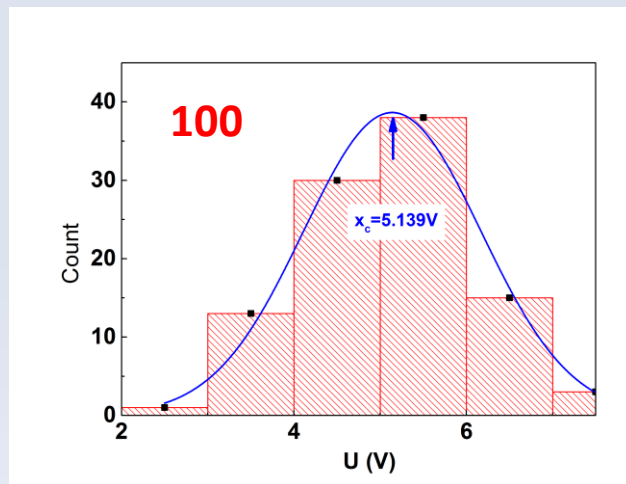
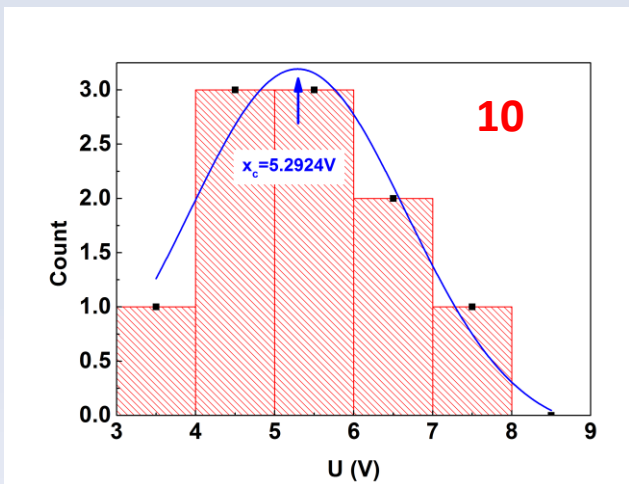

Error in the mean is given as  $\frac{\sigma_0}{\sqrt{N}}$  (This is called standard quantum limit or the shot noise limit or “standard error”)



# Measurement in presence of noise

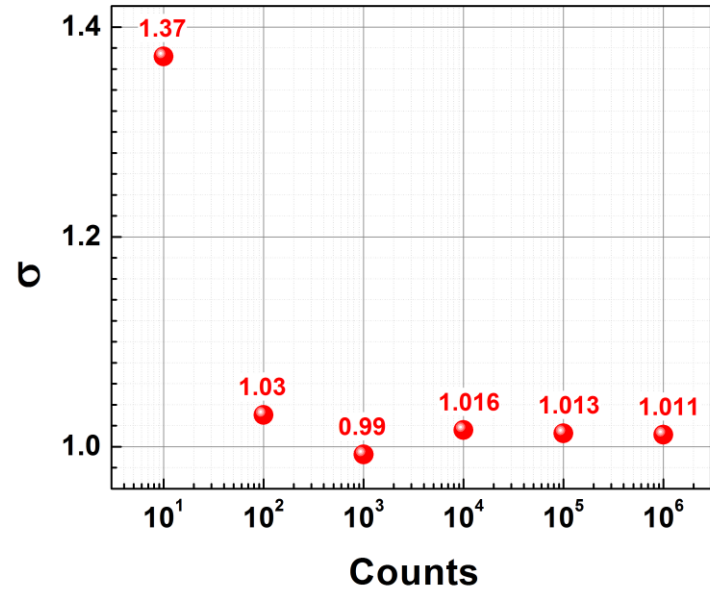
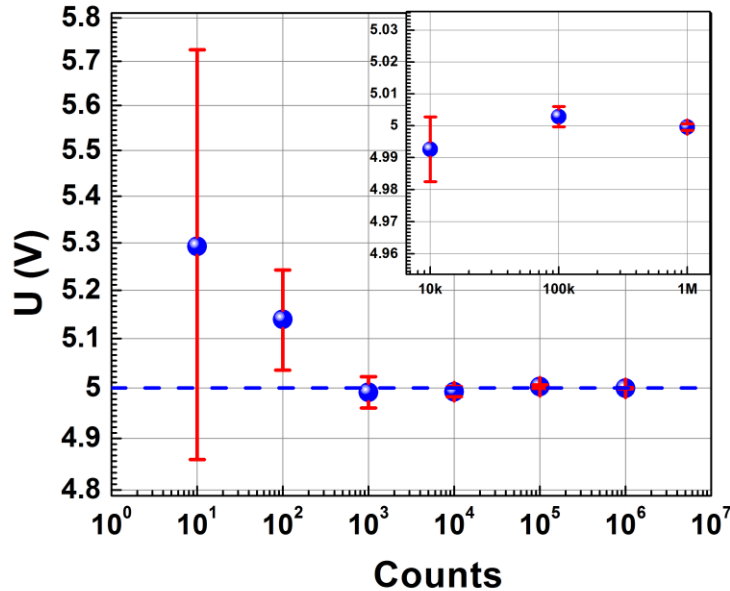

**Result**



$$U = x_c \pm \frac{\sigma_0}{\sqrt{N}}$$

$\sigma_0$ - standard deviation  
N – number of samples

**For N=10<sup>6</sup> U=4.999±0.001**

**0.02% accuracy**





# Heisenberg limit measurements

According to Heisenberg uncertainty,

the ultimate precision of the energy measurement is  $\Delta E \sim \frac{\hbar}{t}$

If  $N$  is the number of measurements performed then  $t = N \cdot t_1$ , where  $t_1$  is the time needed to perform one measurement.

Thus the precision can be as good as  $\Delta E \sim \frac{\hbar}{t_1} \frac{1}{N}$

To achieve this high precision, one has to use a quantum system, such as a **qubit**.



# Fitting errors

## Ag $\beta$ decay

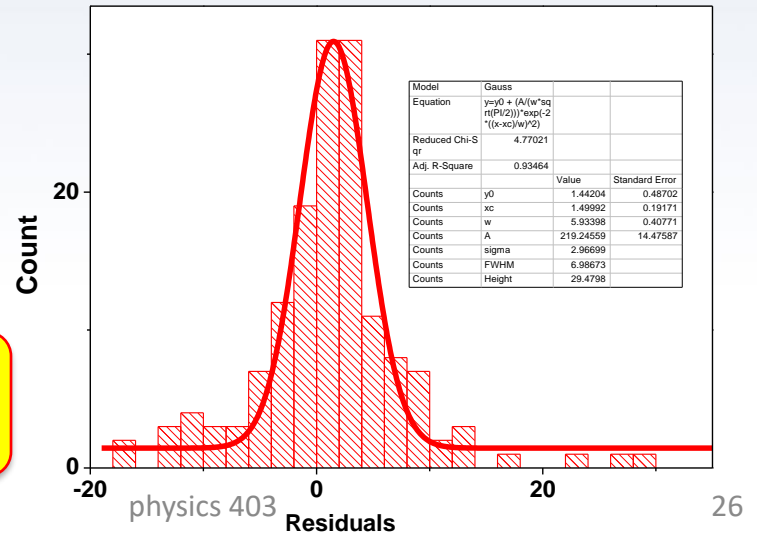
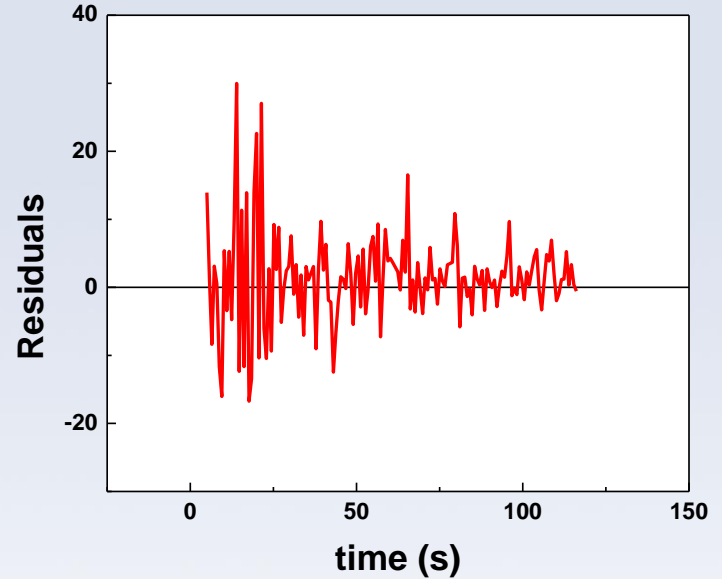
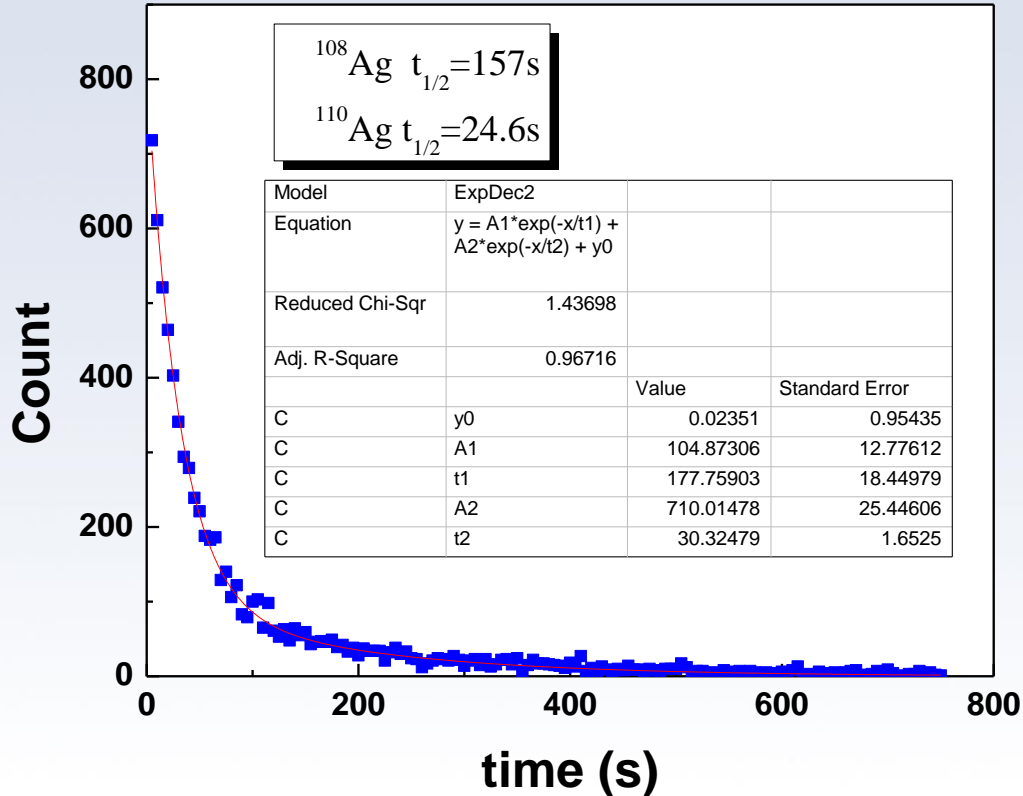

$$y = A1 \cdot \exp\left(\frac{-t}{t_1}\right) + A2 \cdot \exp\left(\frac{-t}{t_2}\right) + y_0$$



# Fitting. Analysis of the deviations

## Ag $\beta$ decay

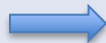
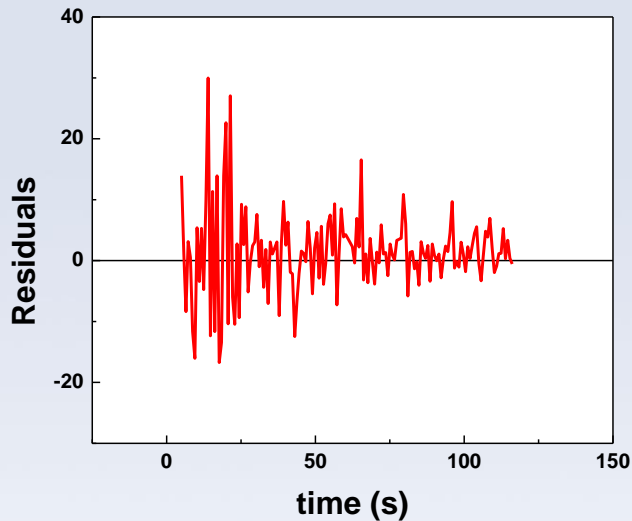

### Test 1. Fourier analysis

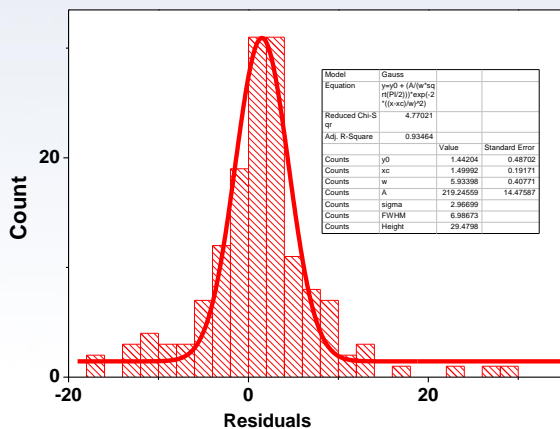
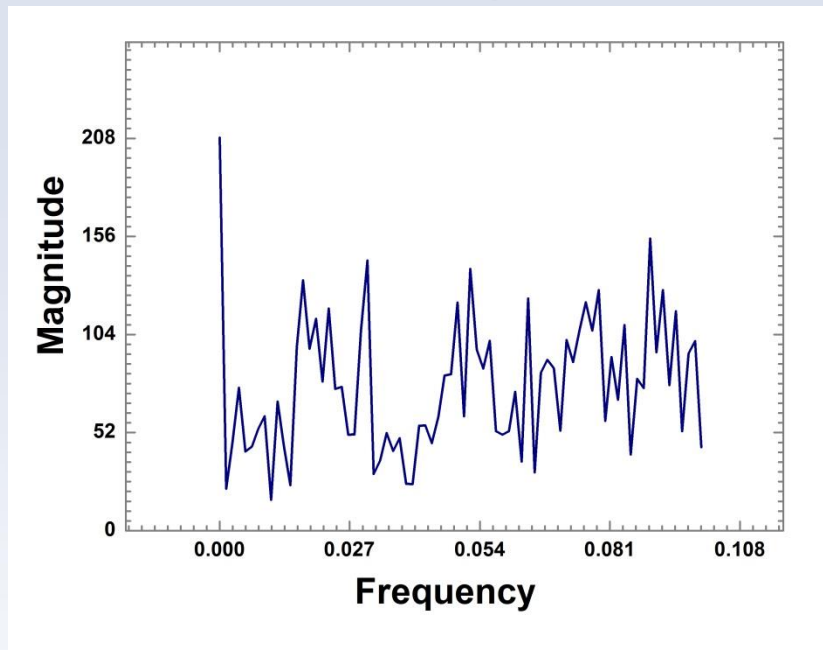

No pronounced frequencies found



# Fitting. Analysis of the residuals

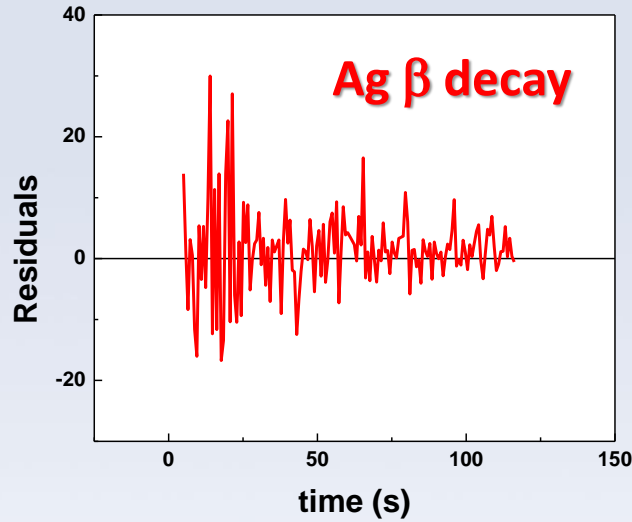

## Test 1. Autocorrelation function

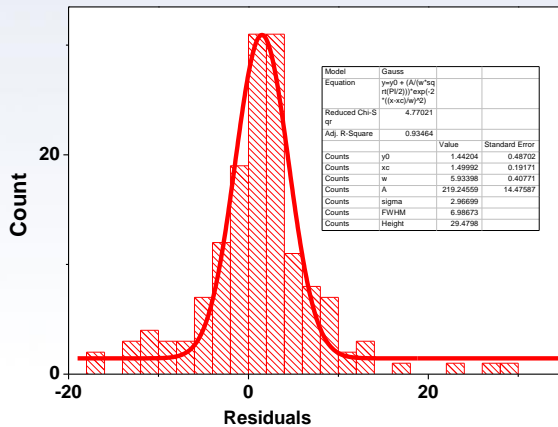
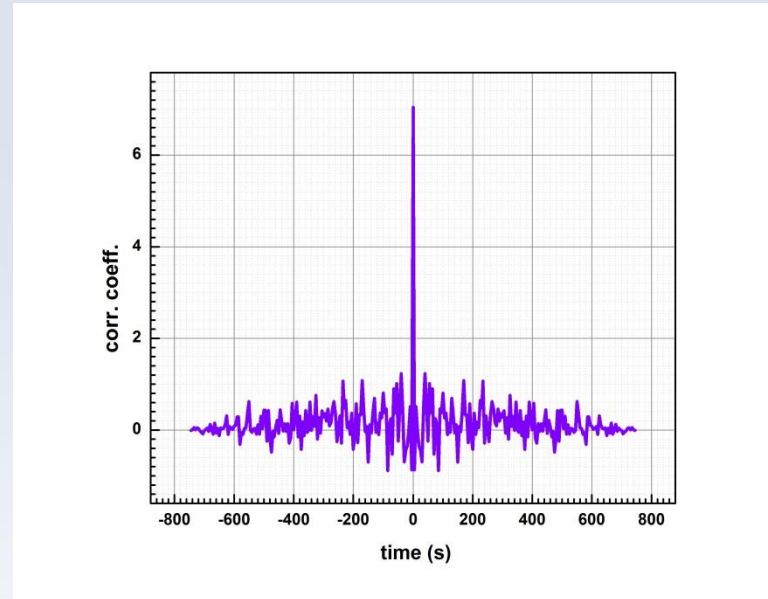

Correlation function

$$y(m) = \sum_{n=0} f(n)g(n-m)$$

autocorrelation function

$$y(m) = \sum_{n=0}^{M-1} f(n)f(n-m)$$



# Fitting. Analysis of the residuals. Non "ideal" case

## Ag $\beta$ decay

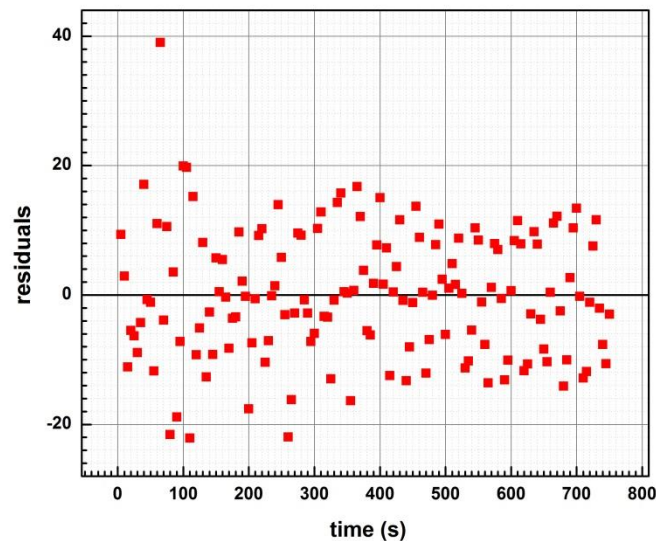
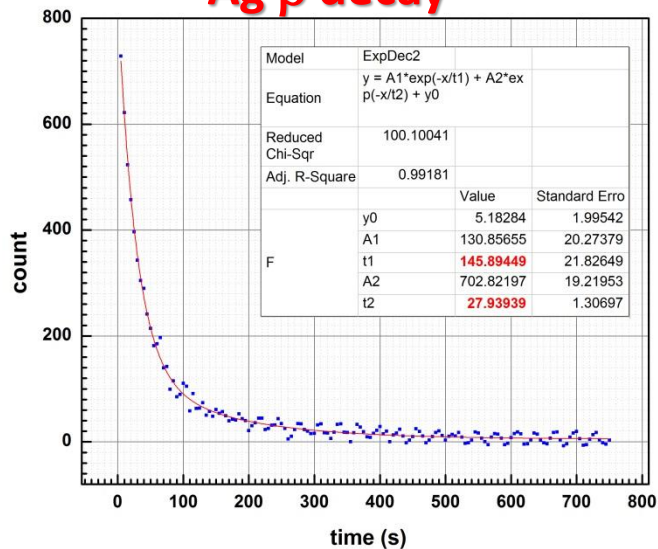

	Clear experiment	Data + "noise"
$t_1(s)$	<b>177.76</b>	<b>145.89</b>
$t_2(s)$	<b>30.32</b>	<b>27.94</b>



# Note: deleting data is not allowed of course

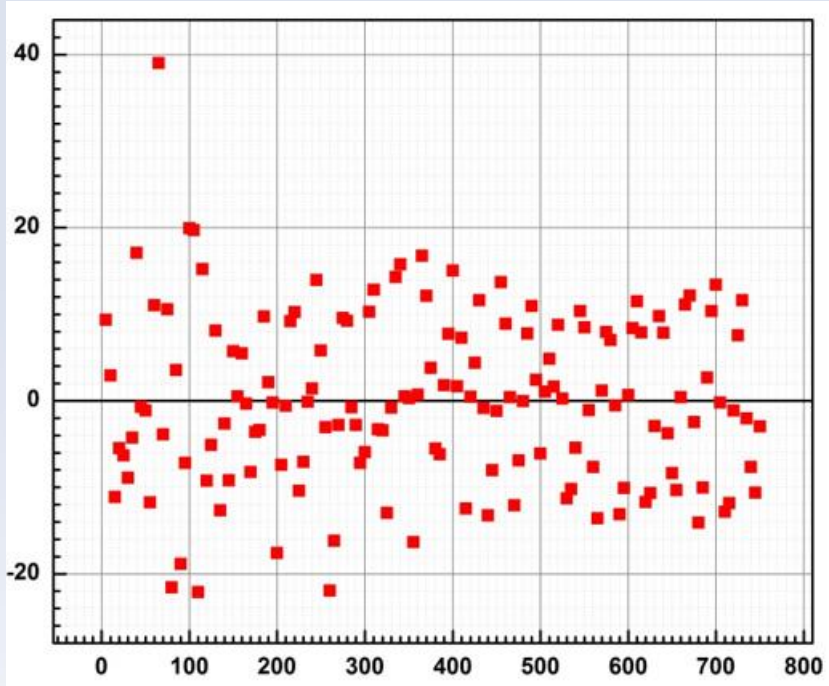

Deleting data point might confirm any model, but such data manipulation is strictly forbidden in science.

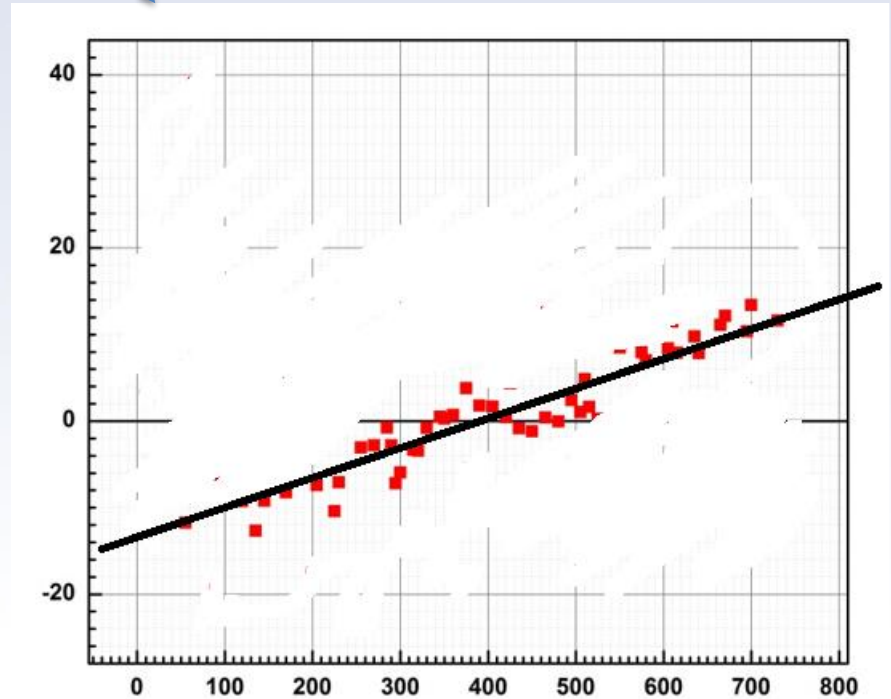

# Fitting. Analysis of the residuals. Non "ideal" case

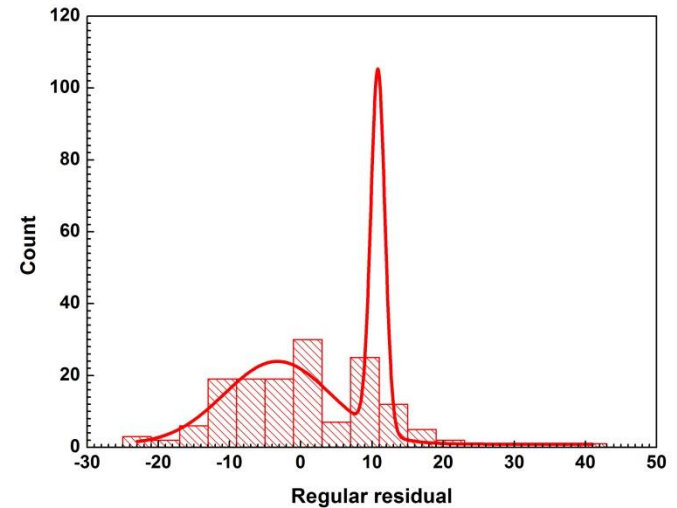
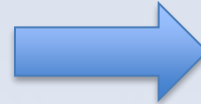
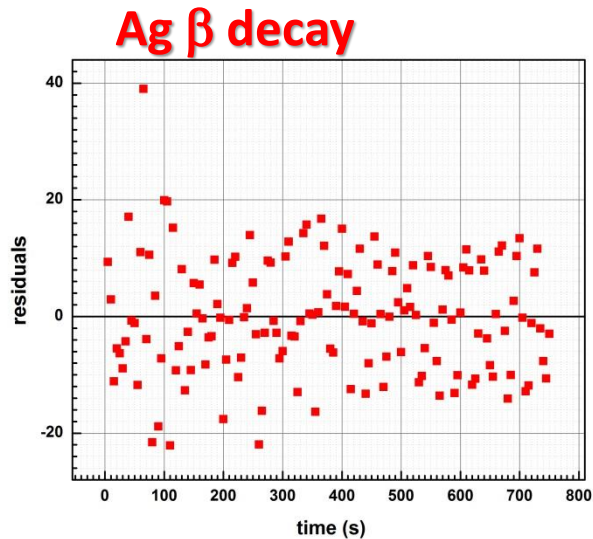

**Histogram does not follow the normal distribution and there is frequency of 0.333 is present in spectrum**

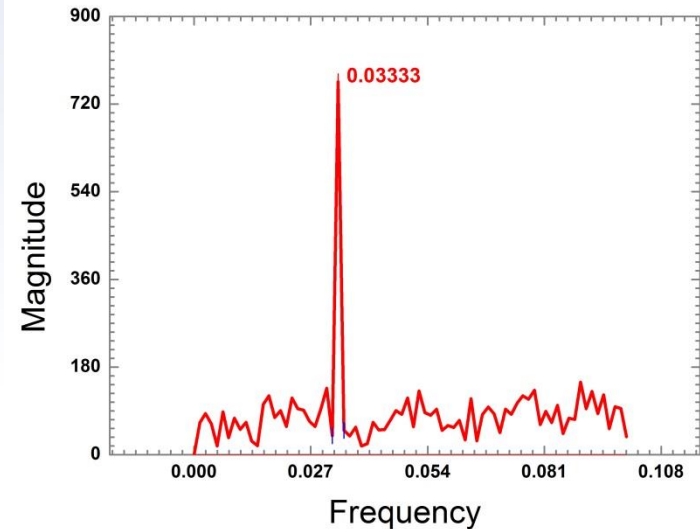

# Fitting. Analysis of the residuals. Non "ideal" case

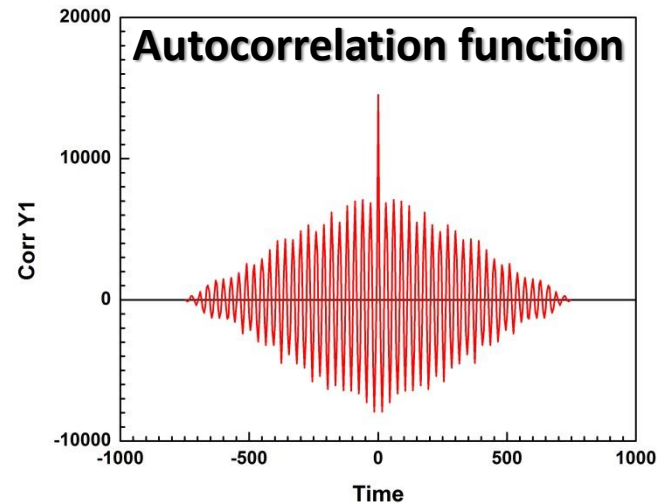
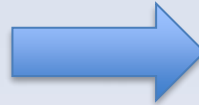
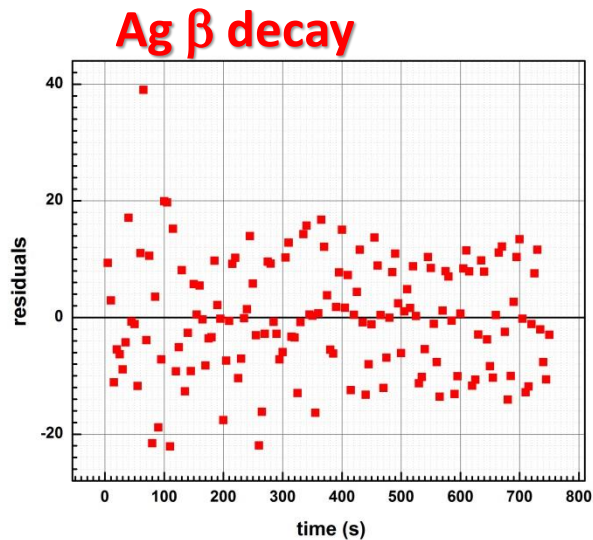

**Conclusion: fitting function should be modified by adding an additional term:**

$$y(t) = y_0 + A_1 \exp\left(\frac{-t}{t_1}\right) + A_2 \exp\left(\frac{-t}{t_2}\right) + A_3 \sin(\omega t + \theta)$$





# Fitting. Analysis of the residuals. Non "ideal" case

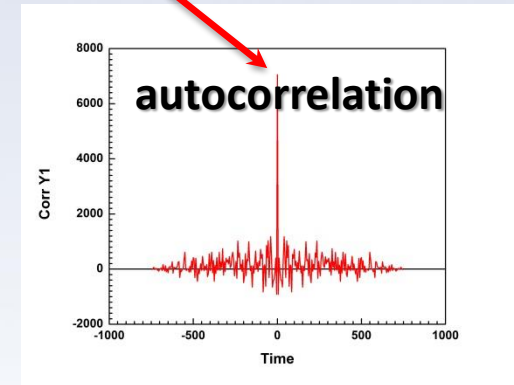
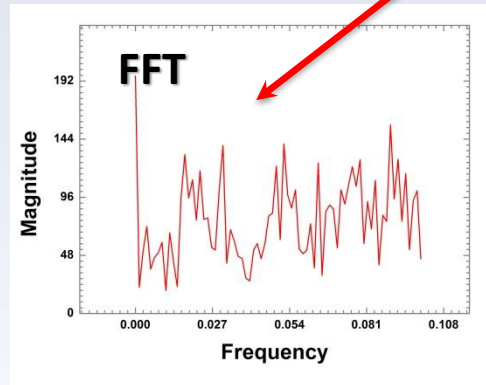
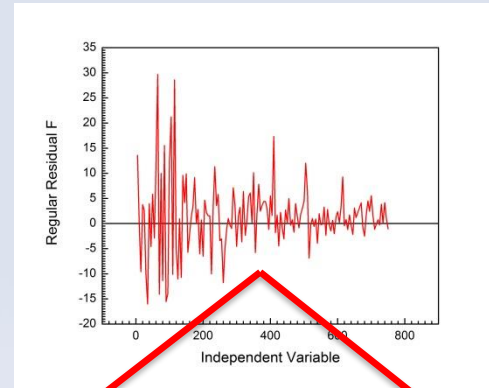
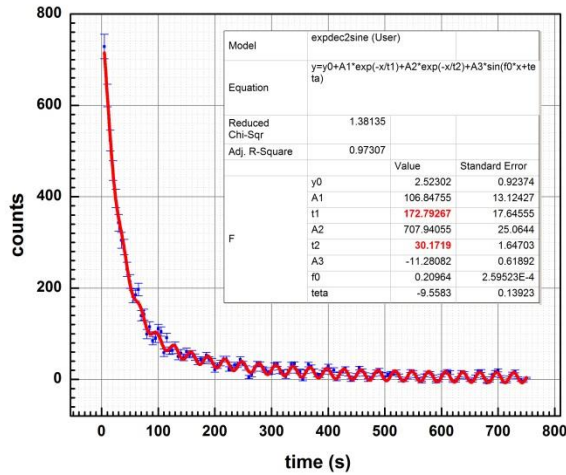

	Clear experiment	Data + noise	Modified fitting
$t_1(s)$	<b>177.76</b>	<b>145.89</b>	<b>172.79</b>
$t_2(s)$	<b>30.32</b>	<b>27.94</b>	<b>30.17</b>



# Error propagation

$$y = f(x_1, x_2 \dots x_n)$$

$$\Delta f(x_i, \Delta x_i) = \sqrt{\sum_{i=1}^n \left[ \frac{\partial f}{\partial x_i} \right]^2 \cdot \Delta x_i^2}$$

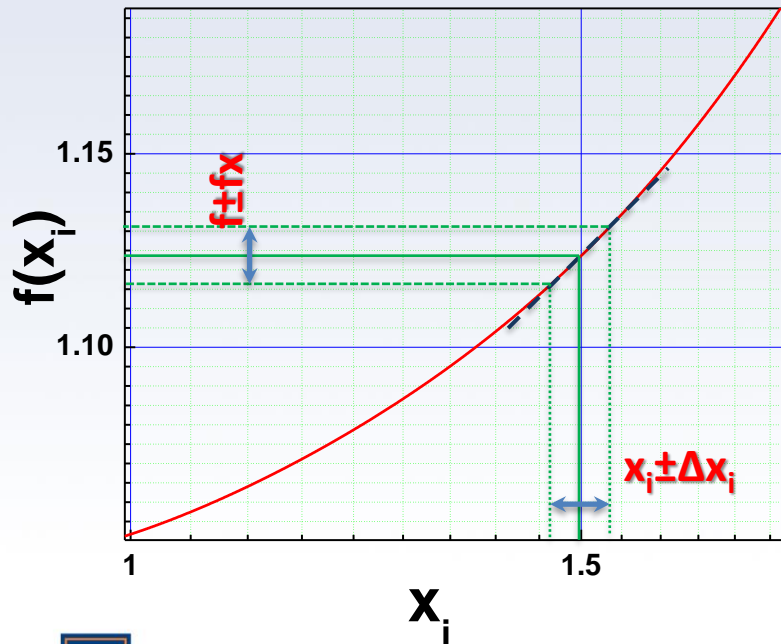

# Error propagation. Example.

Derive resonance frequency  $f$   
from measured inductance  
 $L \pm \Delta L$  and capacitance  $C \pm \Delta C$

$$f(L, C) = \frac{1}{2\pi} \sqrt{\frac{1}{LC}}$$

$$L_1 = 10 \pm 1 \text{mH}, \quad C_1 = 10 \pm 2 \mu\text{F}$$

$$\Delta f(L, C, \Delta L, \Delta C) = \sqrt{\left[\frac{\partial f}{\partial L}\right]^2 \cdot \Delta L^2 + \left[\frac{\partial f}{\partial C}\right]^2 \Delta C^2}$$

$$\frac{\partial f}{\partial L} = \frac{-1}{4\pi} C^{-\frac{1}{2}} L^{-\frac{3}{2}};$$

$$\frac{\partial f}{\partial C} = \frac{-1}{4\pi} L^{-\frac{1}{2}} C^{-\frac{3}{2}}$$

**Results:**

$$f(L_1, C_1) = 503.29212104487 \text{Hz}$$

$$\Delta f = 56.26977 \text{Hz}$$

$$f(L_1, C_1) = 503 \pm 56 \text{Hz}$$



# Presentation of the results. Reports/publications. Condensed Matter Physics.

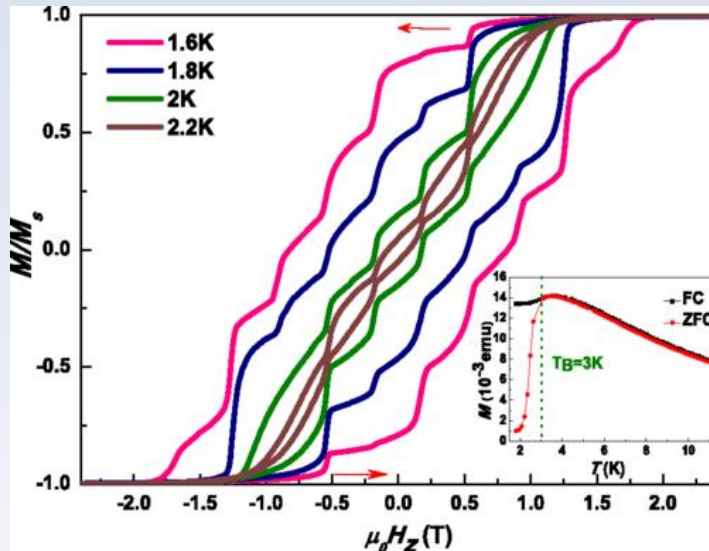

Figure 3. Magnetization ( $M/M_s$ ) of Mn3 single crystal versus applied magnetic field with the sweeping rate of 0.003 T/s at different temperatures. The inset shows ZFC and FC curves.

Phys. Rev. B 89, 184401

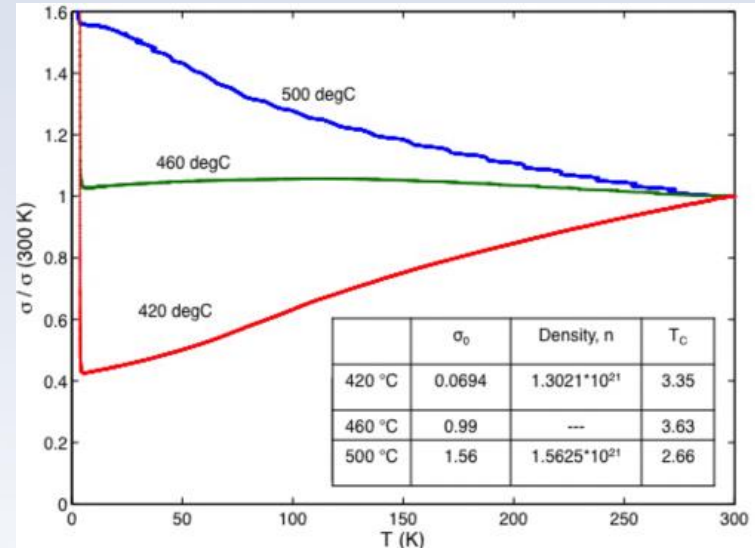
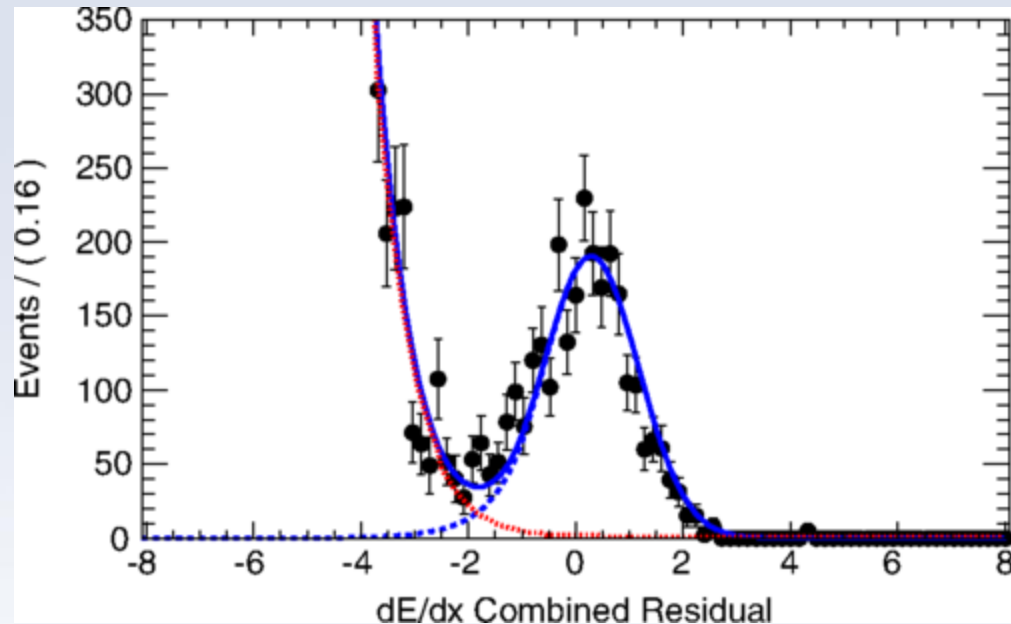

Figure 2. Normalized conductivity vs temperature for three 250-nm-thick  $K_{0.33}WO_{3-y}$  films on YSZ substrates. The films are annealed in vacuum at different temperatures, with properties shown in the inset table. The units of  $T_{anneal}$  are degrees Celcius,  $\sigma_0$  is given in  $1/m\Omega cm$ ,  $n$  in  $/cm^3$ , and  $T_c$  in degrees Kelvin.

Phys. Rev. B 89, 184501

# Presentation of the results. Reports/publications. Particle Physics.

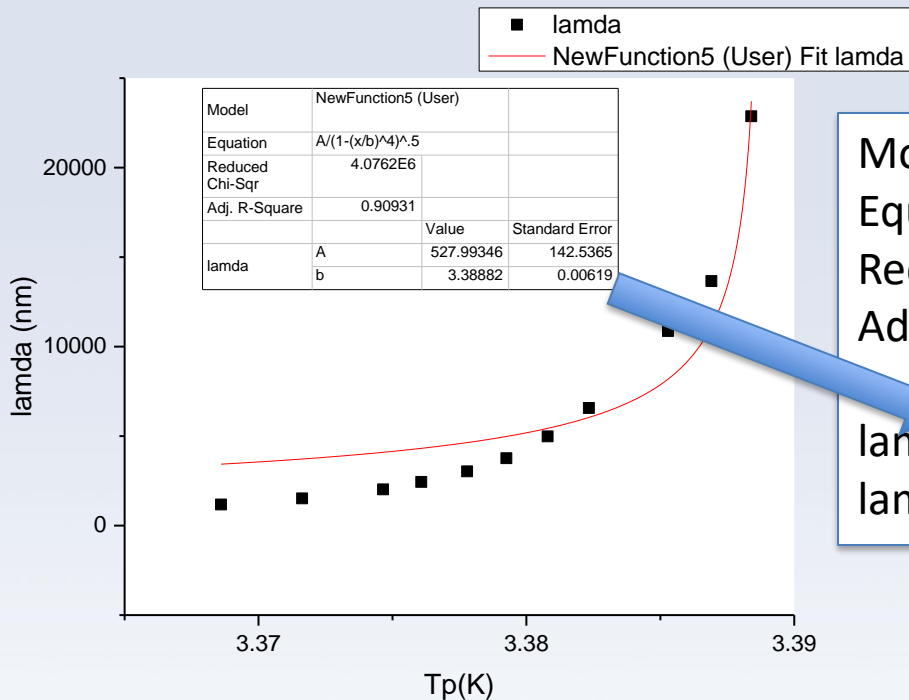

**Figure 1.** Normalized residuals of the combined  $dE/dx$  for antideuteron candidates in the Onpeak  $\Upsilon(2S)$  data sample, with fit PDFs superimposed. Entries have been weighted, as detailed in the text. The solid (blue) line is the total fit, the dashed (blue) line is the  $d^-$  signal peak, and the dotted (red) line is the background.

Phys. Rev. D 89, 111102(R)



# Presentation of the results. Student Reports.



Model	NewFunction5 (User)		
Equation	A/(1-(x/b)^4)^.5		
Reduced Chi-Sqr	4.0762E6		
Adj. R-Square	0.90931		
		Value	Standard Error
lamda	A	527.99346	142.5365
lamda	b	3.38882	0.00619

**Figure 10(ii):** lambda versus T for indium film with thickness 300 nm. Input voltage is 0.2v. Critical temperature(b) and penetration depth(A) at temperature 0 K is determined

1. Units must be written
2. Number of digits must be reasonable

Formula for the fitting curve must be provided



# THE END

