

CS 225

Data Structures

November 16 – Graph Traversal

Wade Fagen-Ulmschneider

Graph ADT

Data:

- Vertices
- Edges
- Some data structure maintaining the structure between vertices and edges.

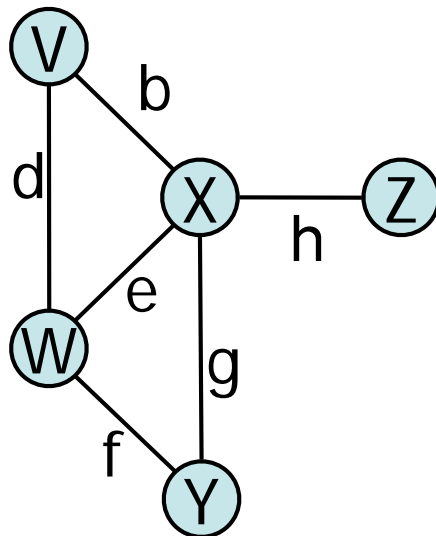

Functions:

- insertVertex(K key);
- insertEdge(Vertex v1, Vertex v2, K key);
- removeVertex(Vertex v);
- removeEdge(Vertex v1, Vertex v2);
- incidentEdges(Vertex v);
- areAdjacent(Vertex v1, Vertex v2);
- origin(Edge e);
- destination(Edge e);

Edge List

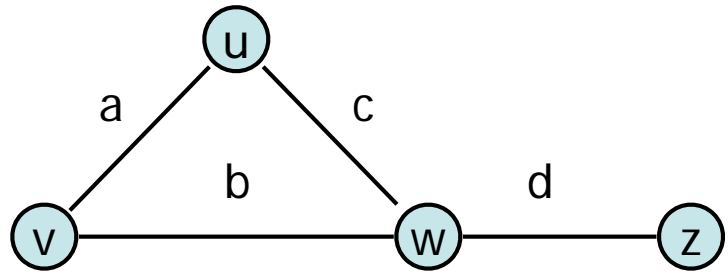

Key Ideas:

- Given a vertex, $O(1)$ lookup in vertex list
 - Implement w/ a hash table, etc
- All basic ADT operations runs in $O(m)$ time

Vertex List

u
v
w
z

Edge List

u	v	a
v	w	b
u	w	c
w	z	d

Adjacency Matrix

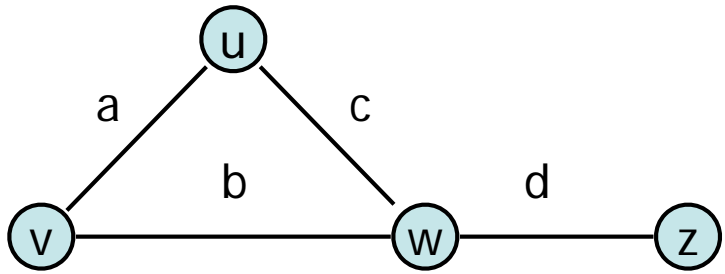

Key Ideas:

- Given a vertex, $O(1)$ lookup in vertex list
- Given a pair of vertices (an edge), $O(1)$ lookup in the matrix
- Undirected graphs can use an upper triangular matrix

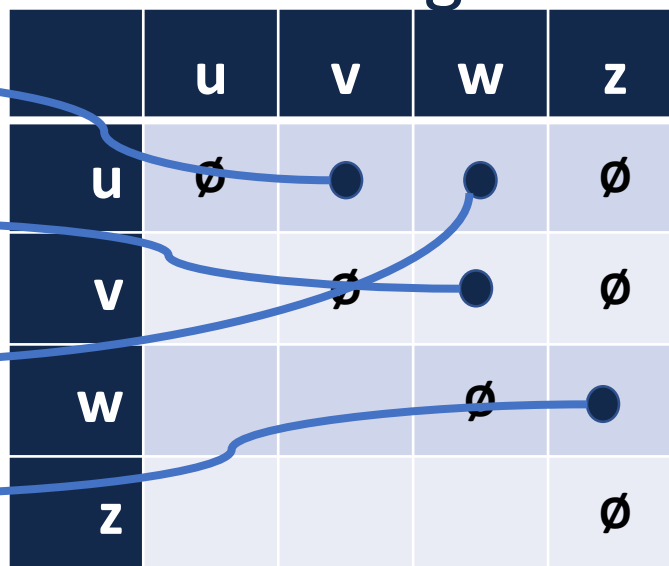
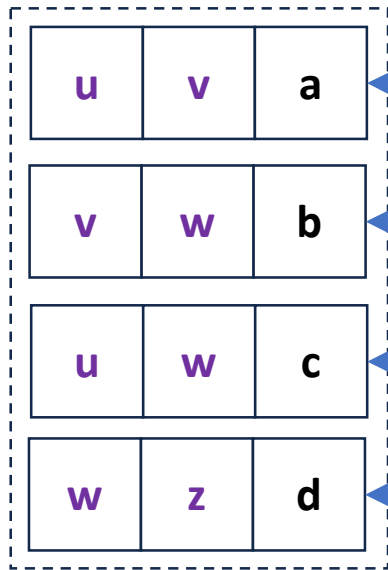
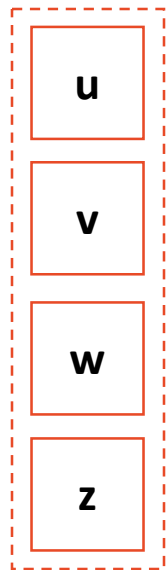

Graph Implementation: Edge List

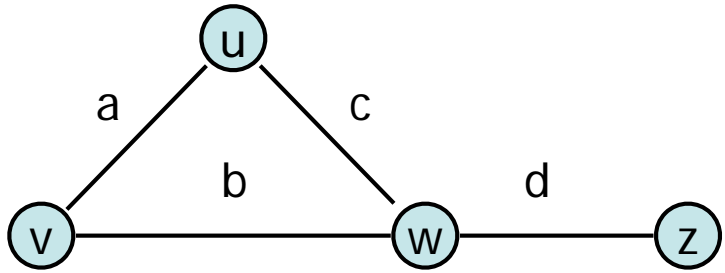

u
v
w
z

u	v	a
v	w	b
u	w	c
w	z	d

Adjacency List

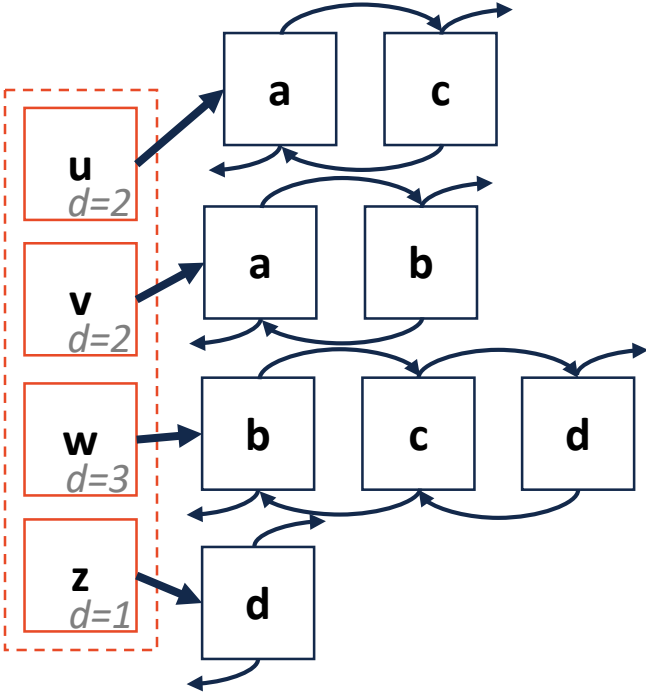
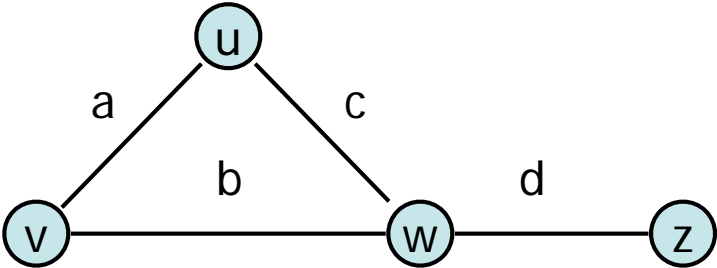

u	v	a
v	w	b
u	w	c
w	z	d

Adjacency List

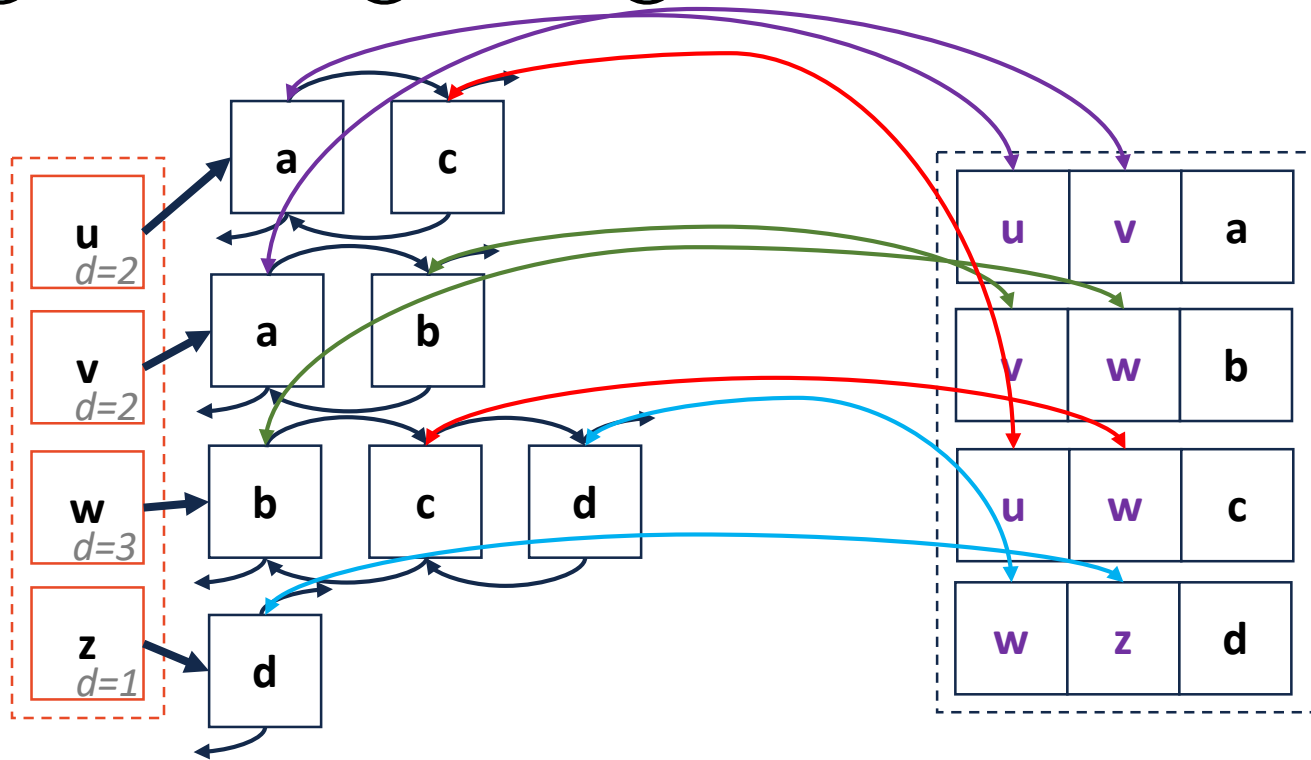
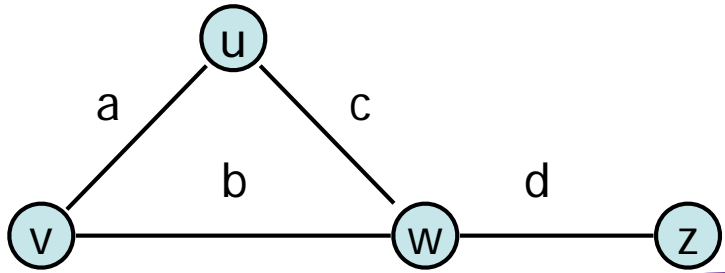

Adjacency List

insertVertex(K key):

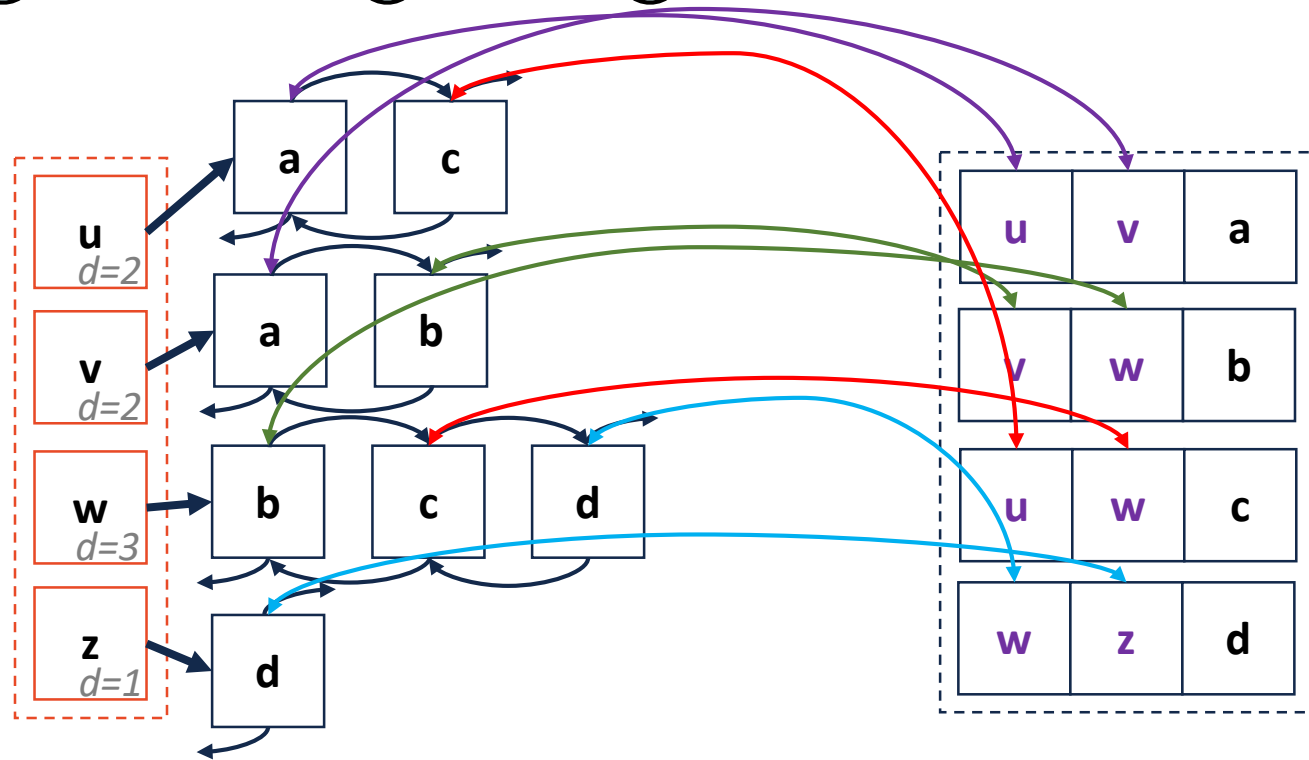
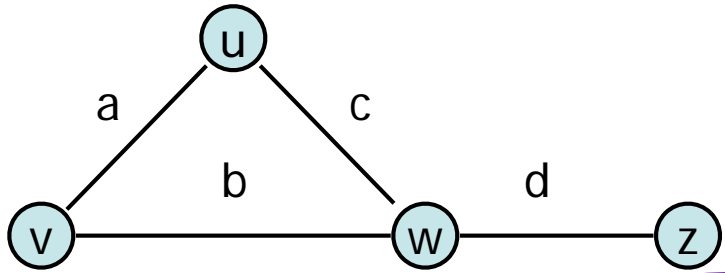

Adjacency List

removeVertex(Vertex v):

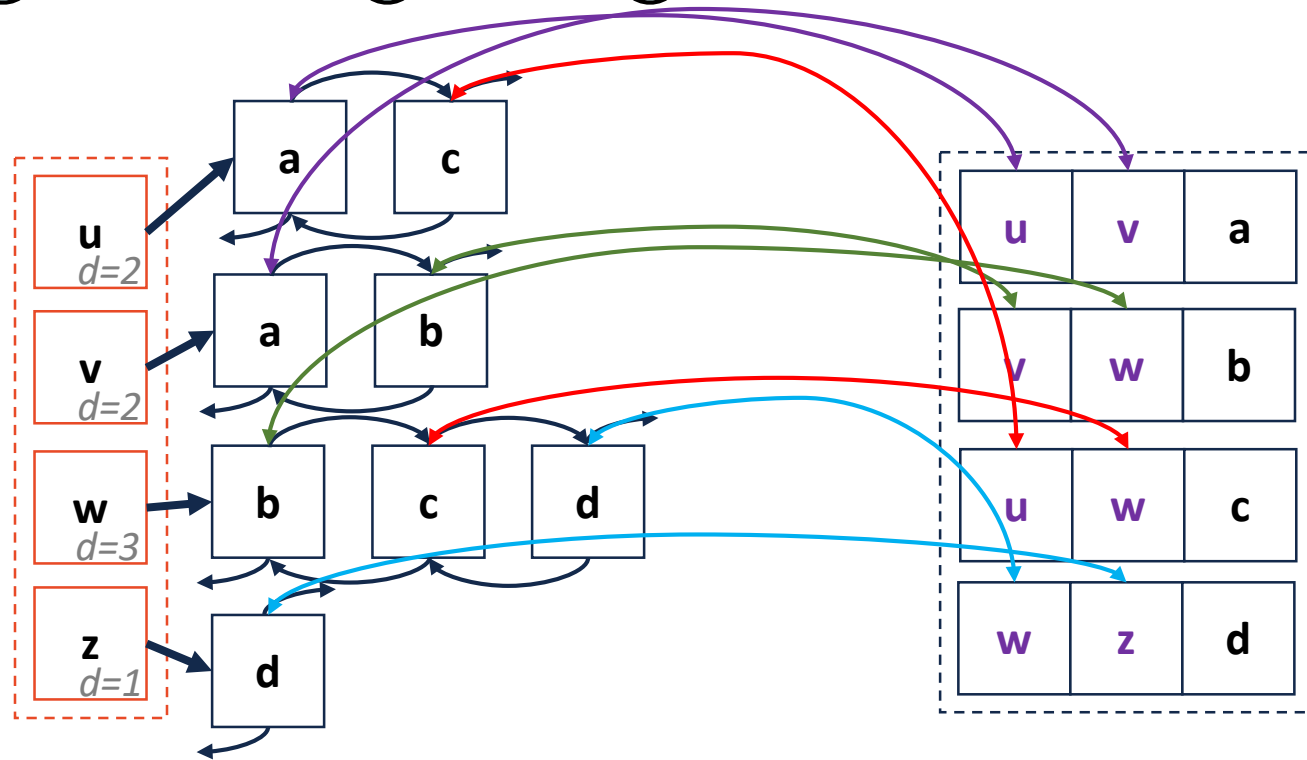
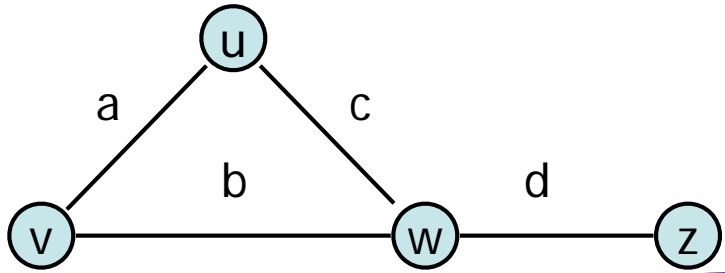

Adjacency List

incidentEdges(Vertex v):

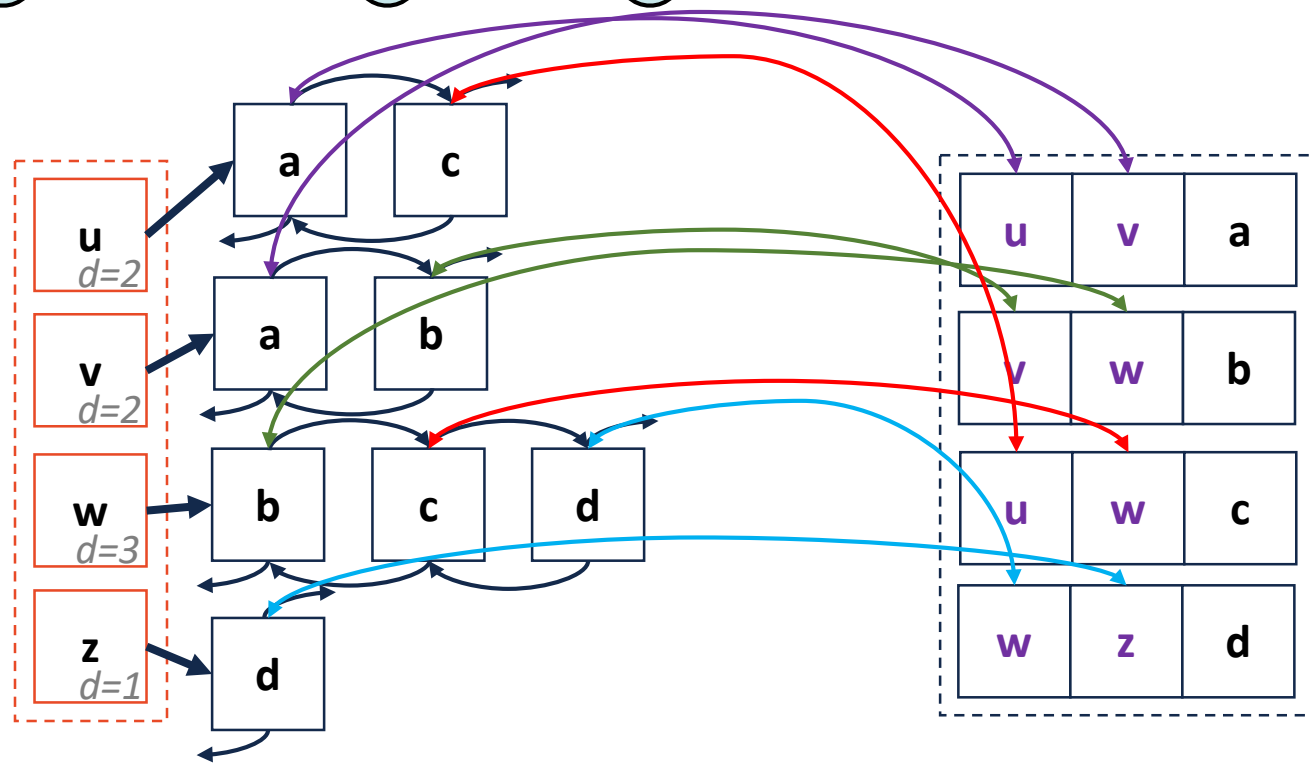
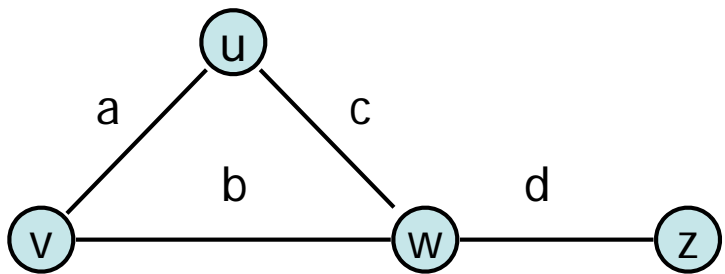

Adjacency List

areAdjacent(Vertex v1, Vertex v2):

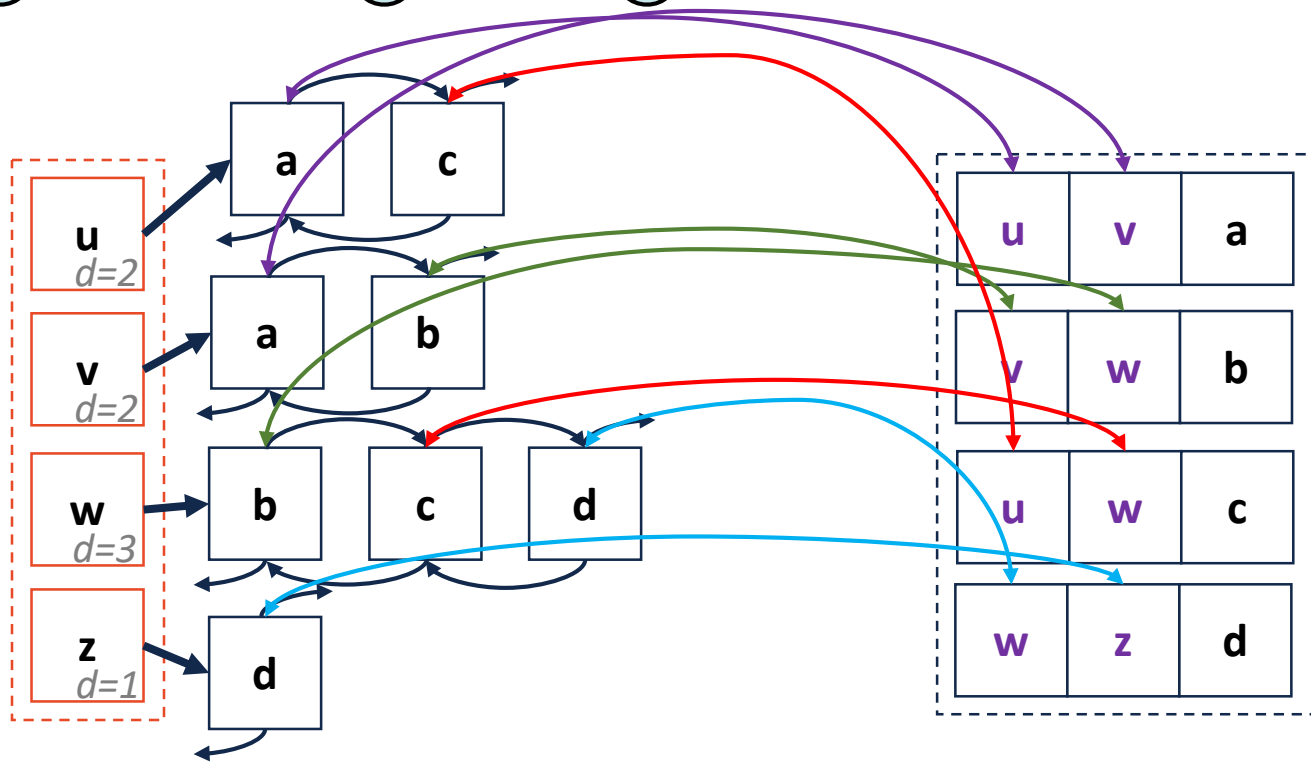
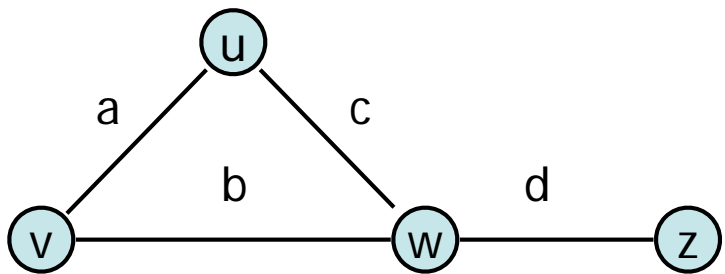

Adjacency List

insertEdge(Vertex v1, Vertex v2, K key):

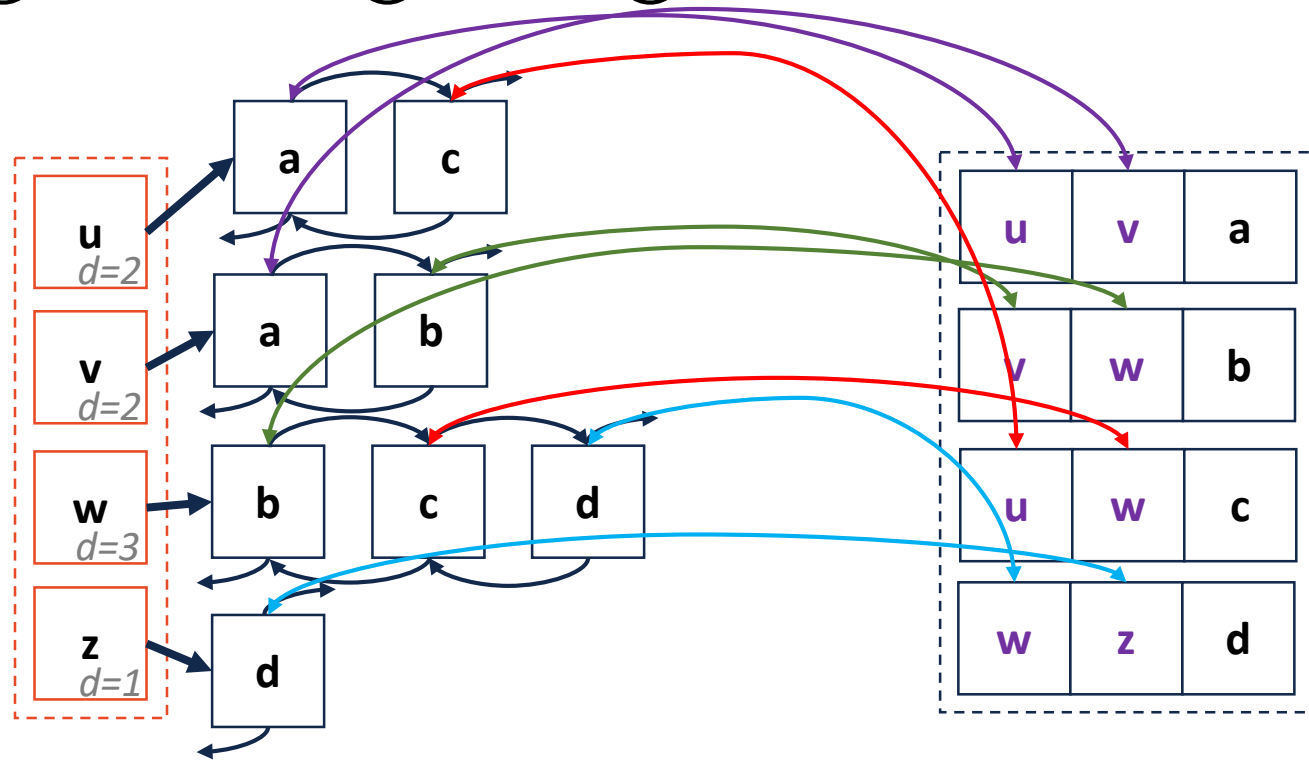
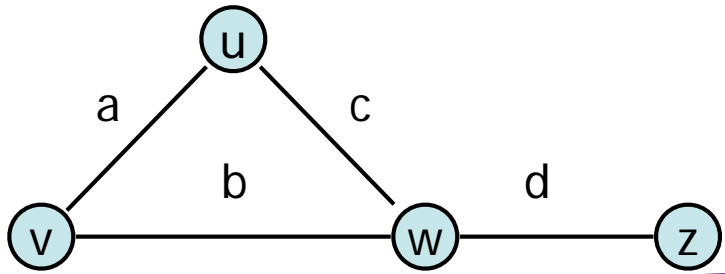

Expressed as O(f)	Edge List	Adjacency Matrix	Adjacency List
Space	$n+m$	n^2	$n+m$
insertVertex(v)	1	n	1
removeVertex(v)	m	n	deg(v)
insertEdge(v, w, k)	1	1	1
removeEdge(v, w)	1	1	1
incidentEdges(v)	m	n	deg(v)
areAdjacent(v, w)	m	1	min(deg(v), deg(w))

Traversal:

Objective: Visit every vertex and every edge in the graph.

Purpose: Search for interesting sub-structures in the graph.

We've seen traversal beforebut it's different:

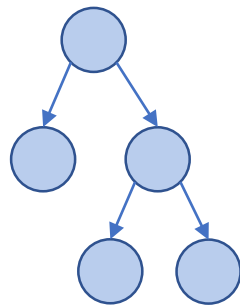

- Ordered
- Obvious Start
-

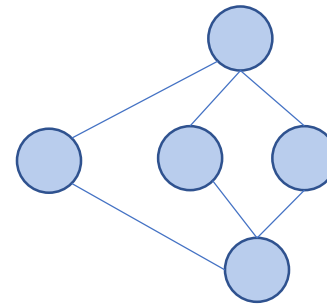

-
-
-

Traversal: BFS

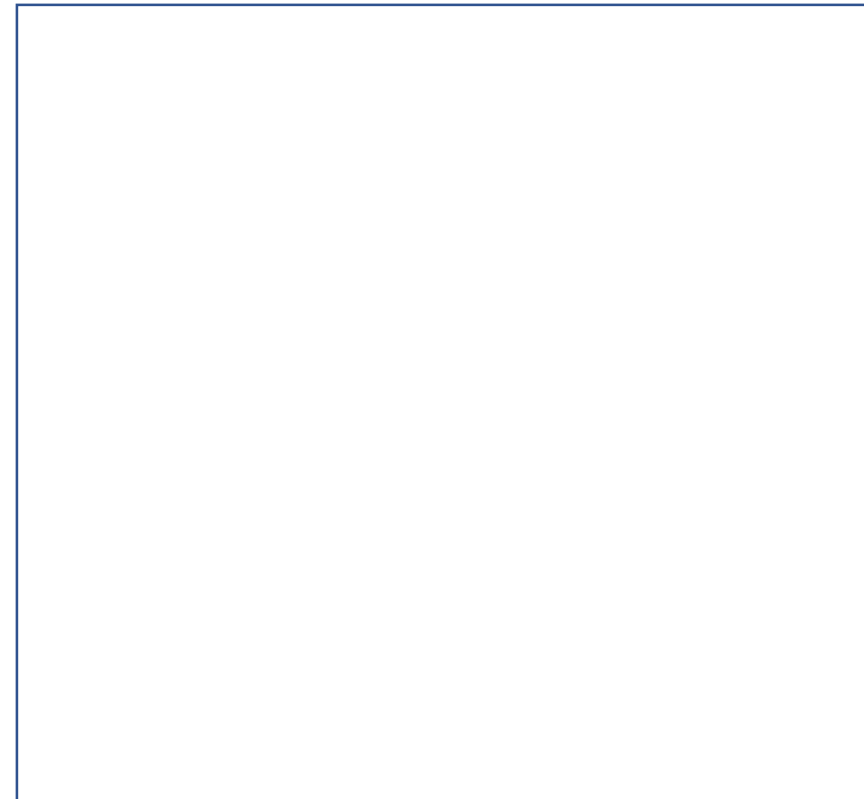
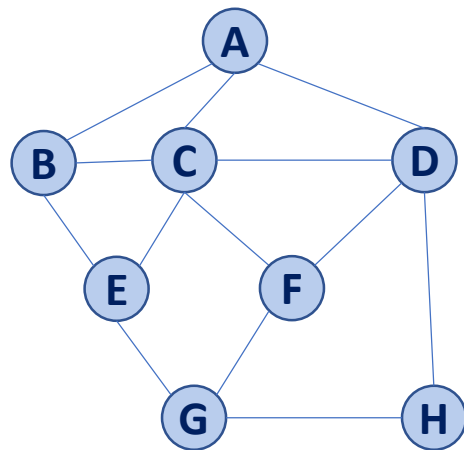

Traversal: BFS

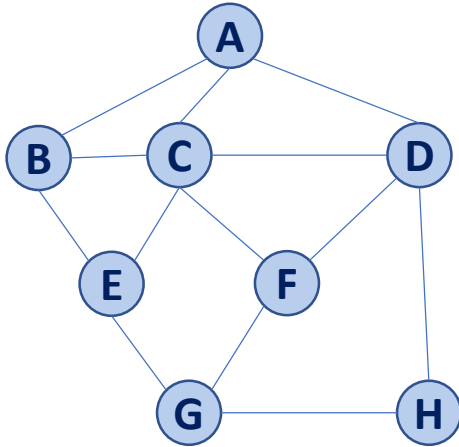

v	d	P	Adjacent Edges
A			
B			
C			
D			
E			
F			
G			
H			



Traversal: BFS

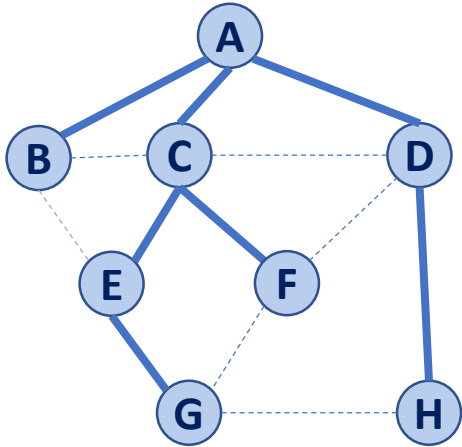

d	p	Adjacent Edges
0	A	A C B D
1	A	B A C E
1	A	C B A D E F
1	A	D A C F H
2	C	E B C G
2	C	F C D G
3	E	G E F H
2	D	H D G



```
1 BFS(G):
2   Input: Graph, G
3   Output: A labeling of the edges on
4           G as discovery and cross edges
5
6   foreach (Vertex v : G.vertices()):
7       setLabel(v, UNEXPLORED)
8   foreach (Edge e : G.edges()):
9       setLabel(e, UNEXPLORED)
10  foreach (Vertex v : G.vertices()):
11      if getLabel(v) == UNEXPLORED:
12          BFS(G, v)
```

```
14 BFS(G, v):
15     Queue q
16     setLabel(v, VISITED)
17     q.enqueue(v)
18
19     while !q.empty():
20         v = q.dequeue()
21         foreach (Vertex w : G.adjacent(v)):
22             if getLabel(w) == UNEXPLORED:
23                 setLabel(v, w, DISCOVERY)
24                 setLabel(w, VISITED)
25                 q.enqueue(w)
26             elseif getLabel(v, w) == UNEXPLORED:
27                 setLabel(v, w, CROSS)
```

BFS Analysis

Q: Does our implementation handle disjoint graphs?
If so, what code handles this?

- ***How do we use this to count components?***

Q: Does our implementation detect a cycle?

- ***How do we update our code to detect a cycle?***

Q: What is the running time?

Running time of BFS

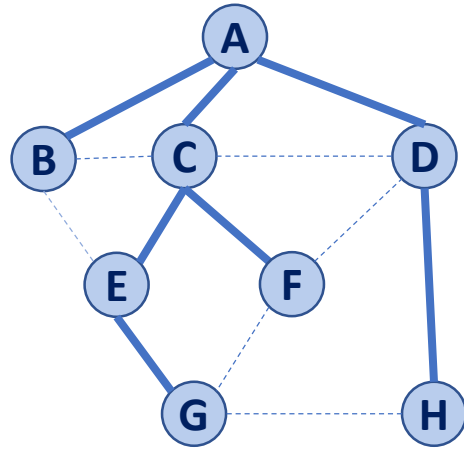

While-loop at **:19?**

For-loop at **:21?**

d	p	v	Adjacent
0	A	A	C B D
1	A	B	A C E
1	A	C	B A D E F
1	A	D	A C F H
2	C	E	B C G
2	C	F	C D G
3	E	G	E F H
2	D	H	D G



```
1 BFS(G):
2   Input: Graph, G
3   Output: A labeling of the edges on
4           G as discovery and cross edges
5
6   foreach (Vertex v : G.vertices()):
7       setLabel(v, UNEXPLORED)
8   foreach (Edge e : G.edges()):
9       setLabel(e, UNEXPLORED)
10  foreach (Vertex v : G.vertices()):
11      if getLabel(v) == UNEXPLORED:
12          BFS(G, v)
```

```
14 BFS(G, v):
15   Queue q
16   setLabel(v, VISITED)
17   q.enqueue(v)
18
19   while !q.empty():
20       v = q.dequeue()
21       foreach (Vertex w : G.adjacent(v)):
22           if getLabel(w) == UNEXPLORED:
23               setLabel(v, w, DISCOVERY)
24               setLabel(w, VISITED)
25               q.enqueue(w)
26           elseif getLabel(v, w) == UNEXPLORED:
27               setLabel(v, w, CROSS)
```

BFS Observations

Q: What is a shortest path from **A** to **H**?

Q: What is a shortest path from **E** to **H**?

Q: How does a cross edge relate to **d**?

Q: What structure is made from discovery edges?

d	p	v	Adjacent
0	A	A	C B D
1	A	B	A C E
1	A	C	B A D E F
1	A	D	A C F H
2	C	E	B C G
2	C	F	C D G
3	E	G	E F H
2	D	H	D G

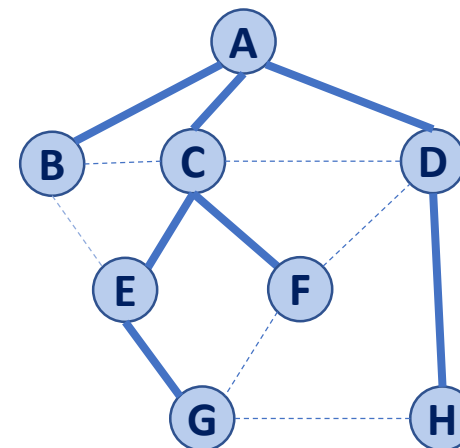

BFS Observations

Obs. 1: Traversals can be used to count components.

Obs. 2: Traversals can be used to detect cycles.

Obs. 3: In BFS, **d** provides the shortest distance to every vertex.

Obs. 4: In BFS, the endpoints of a cross edge never differ in distance, **d**, by more than 1:

$$|d(u) - d(v)| = 1$$

Traversal: DFS

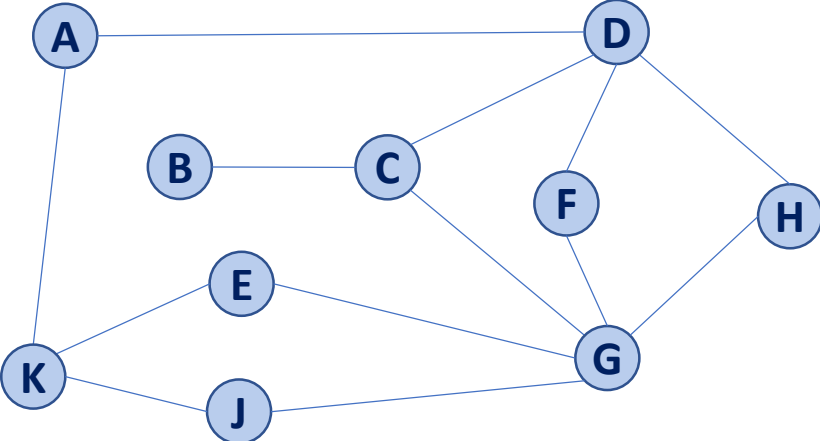

```
1 BFS(G):
2   Input: Graph, G
3   Output: A labeling of the edges on
4           G as discovery and cross edges
5
6   foreach (Vertex v : G.vertices()):
7       setLabel(v, UNEXPLORED)
8   foreach (Edge e : G.edges()):
9       setLabel(e, UNEXPLORED)
10  foreach (Vertex v : G.vertices()):
11      if getLabel(v) == UNEXPLORED:
12          BFS(G, v)
```

```
14 BFS(G, v):
15     Queue q
16     setLabel(v, VISITED)
17     q.enqueue(v)
18
19     while !q.empty():
20         v = q.dequeue()
21         foreach (Vertex w : G.adjacent(v)):
22             if getLabel(w) == UNEXPLORED:
23                 setLabel(v, w, DISCOVERY)
24                 setLabel(w, VISITED)
25                 q.enqueue(w)
26             elseif getLabel(v, w) == UNEXPLORED:
27                 setLabel(v, w, CROSS)
```

```
1 DFS(G):
2   Input: Graph, G
3   Output: A labeling of the edges on
4           G as discovery and back edges
5
6   foreach (Vertex v : G.vertices()):
7       setLabel(v, UNEXPLORED)
8   foreach (Edge e : G.edges()):
9       setLabel(e, UNEXPLORED)
10  foreach (Vertex v : G.vertices()):
11      if getLabel(v) == UNEXPLORED:
12          DFS(G, v)
```

```
14 DFS(G, v):
15 — Queue q
16   setLabel(v, VISITED)
17 — q.enqueue(v)
18
19 — while !q.empty():
20 — v = q.dequeue()
21   foreach (Vertex w : G.adjacent(v)):
22       if getLabel(w) == UNEXPLORED:
23           setLabel(v, w, DISCOVERY)
24           setLabel(w, VISITED)
25           DFS(G, w)
26       elseif getLabel(v, w) == UNEXPLORED:
27           setLabel(v, w, BACK)
```

Running time of DFS

Labeling:

- Vertex:

- Edge:

Queries:

- Vertex:

- Edge:

