



Control and Optimization



Example Design Goals

- Prevent overheating
- Meet deadlines
- Save energy



Design Goals

- Prevent overheating
 - Meet deadlines
 - Save energy
-
- Question: what the safety, mission, and performance requirements here?



Design Goals

- Prevent overheating (safety requirement)
 - Meet deadlines (Mission requirement)
 - Save energy (Performance requirement)
-
- Question: what the safety, mission, and performance requirements here?

Thermal and Energy Management

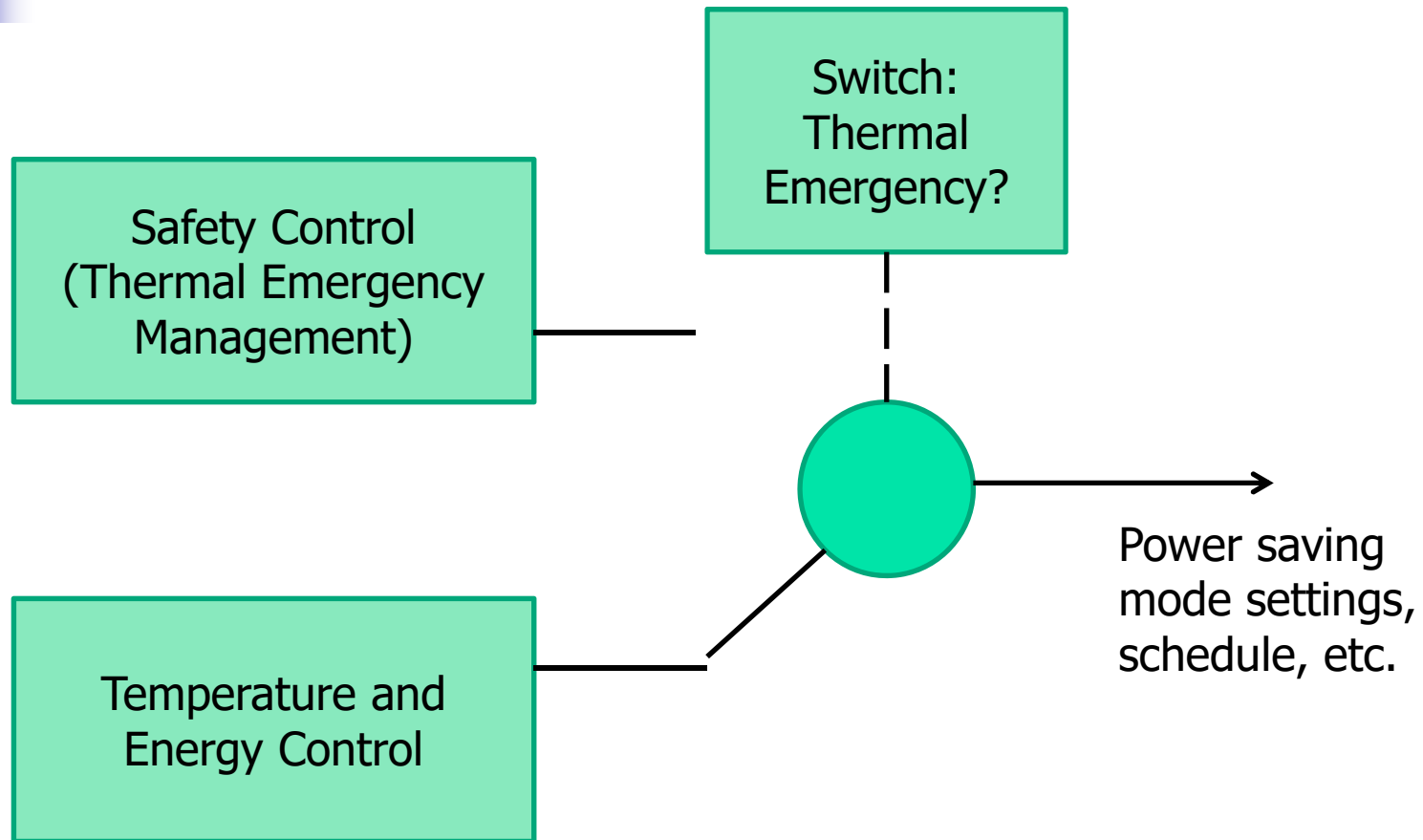

Thermal and Energy Management

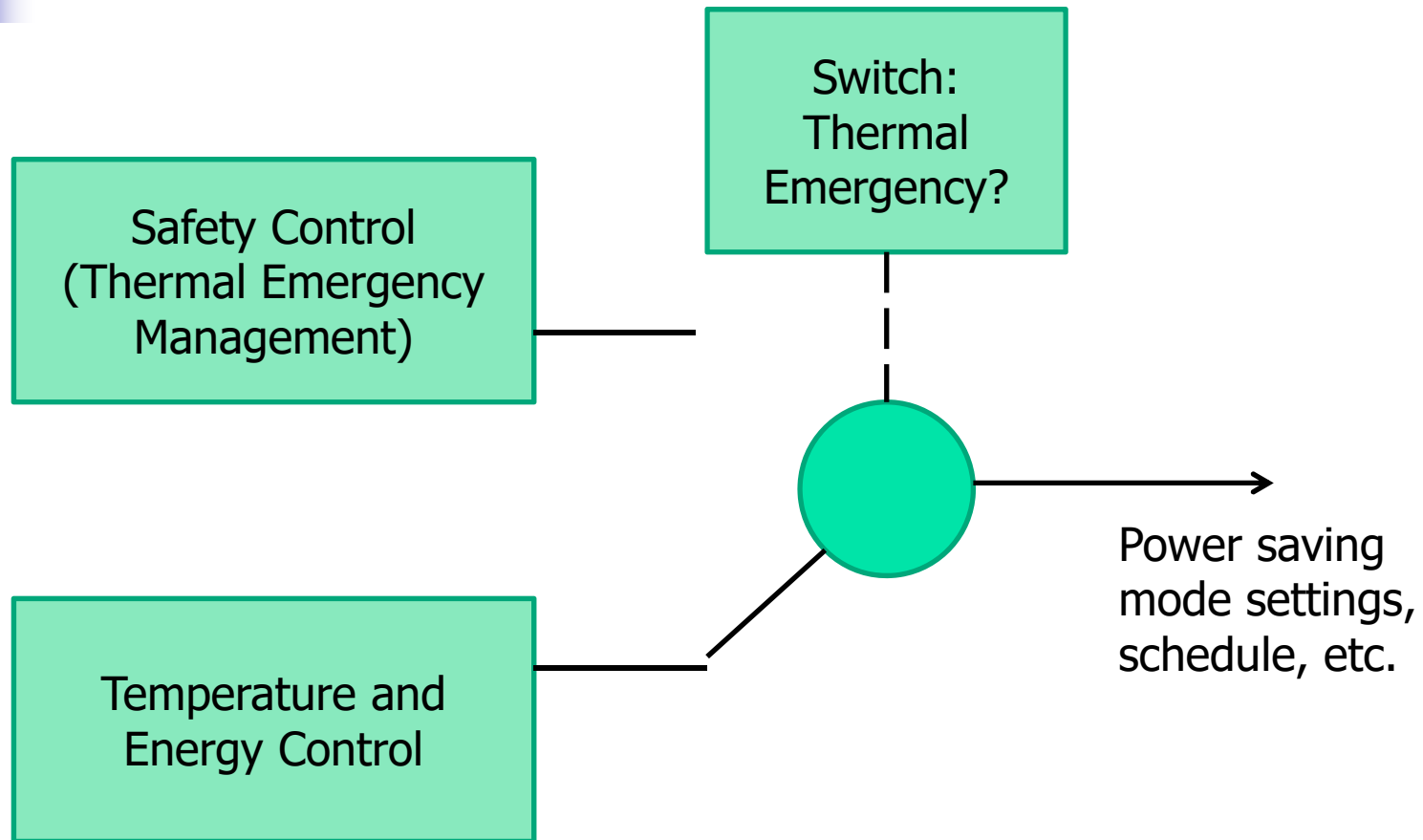

Operate as close to the thermal limit as is safe, but without exceeding it

Thermal and Energy Management

- Target temperature, emergency temperature, and meltdown temperature:

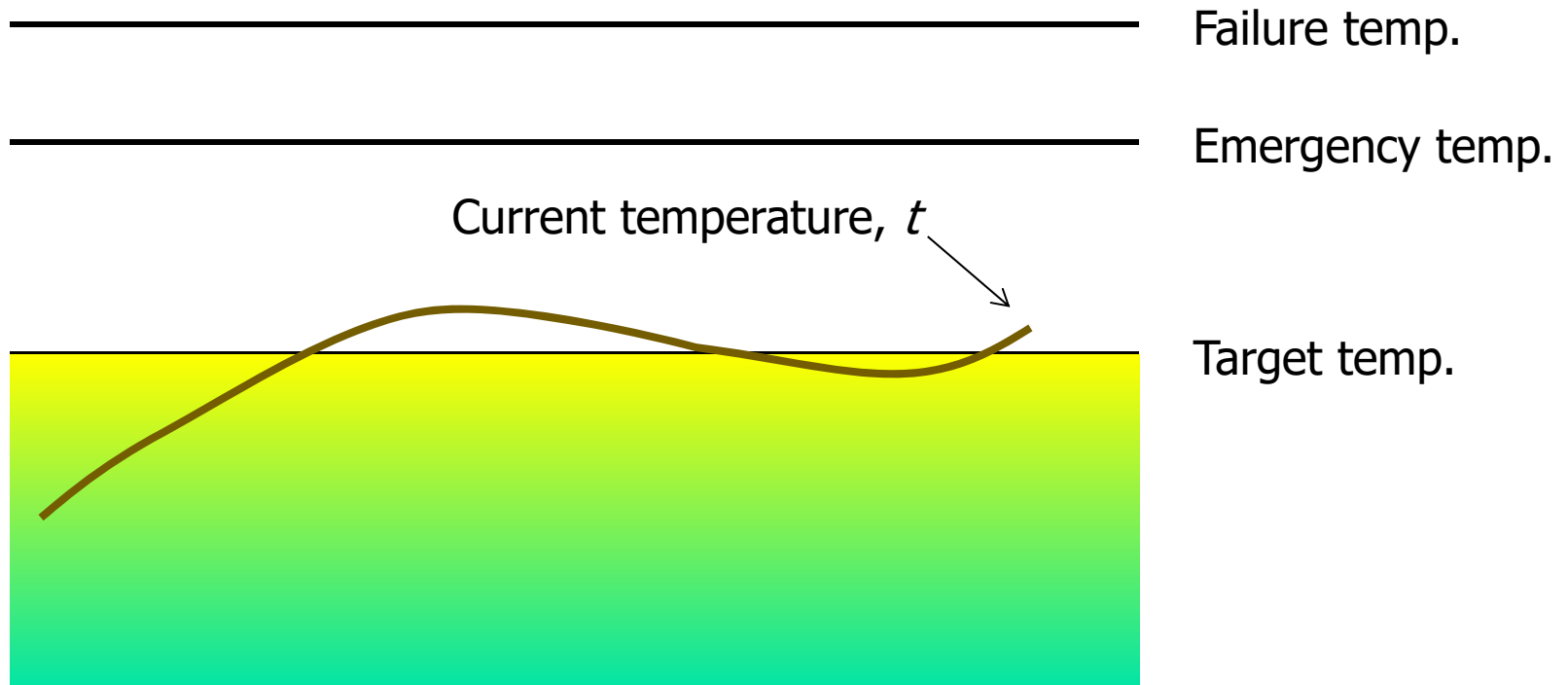



Relation of Temperature and Energy

- The rate of change of temperature is proportional to the difference between input power and output power (via cooling)

$$\frac{dT}{dt} = P_{in} - P_{out}$$

$$P_{in} = f(DVS, sleep)$$

$$P_{out} = g(T)$$

Scheduling and Feedback Control



- Feedback control corrects quality deviations or performance deviations in the physical world
- Feedback control loops sample the environment, determine how far it is from “desired state” then actuate in a direction that approaches desired state

Classical Feedback Control Loops

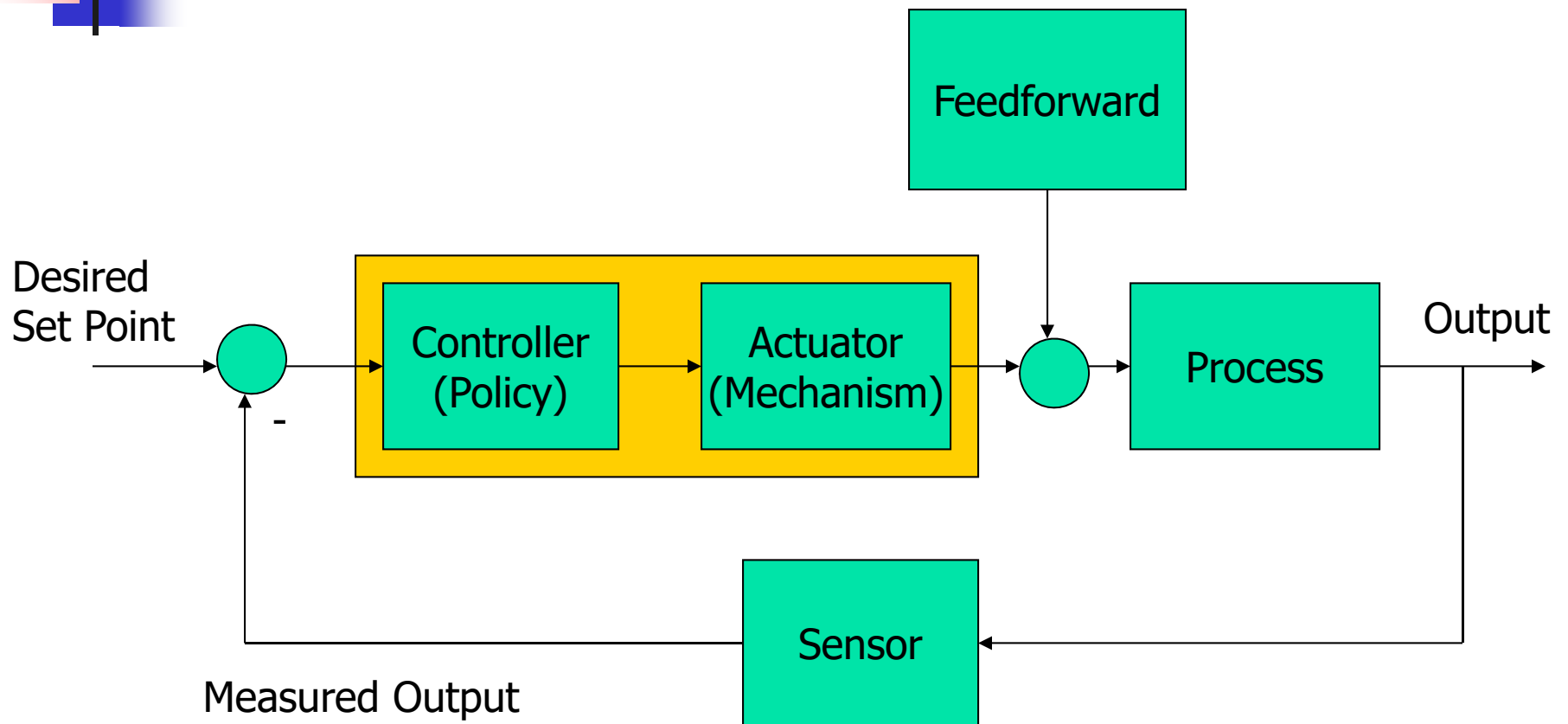

Feedback Control

The loop represents a *causality chain*

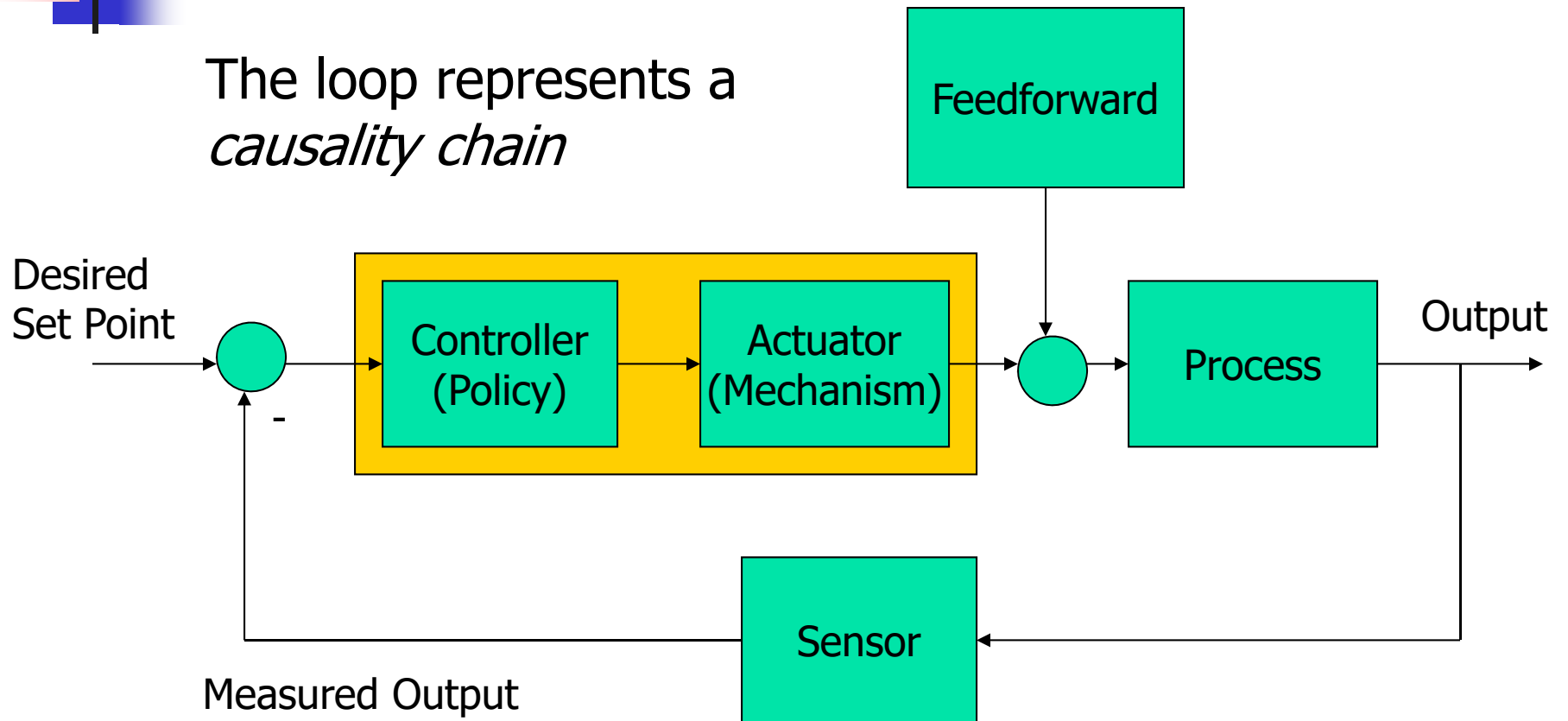

Non-CS Feedback Control Example

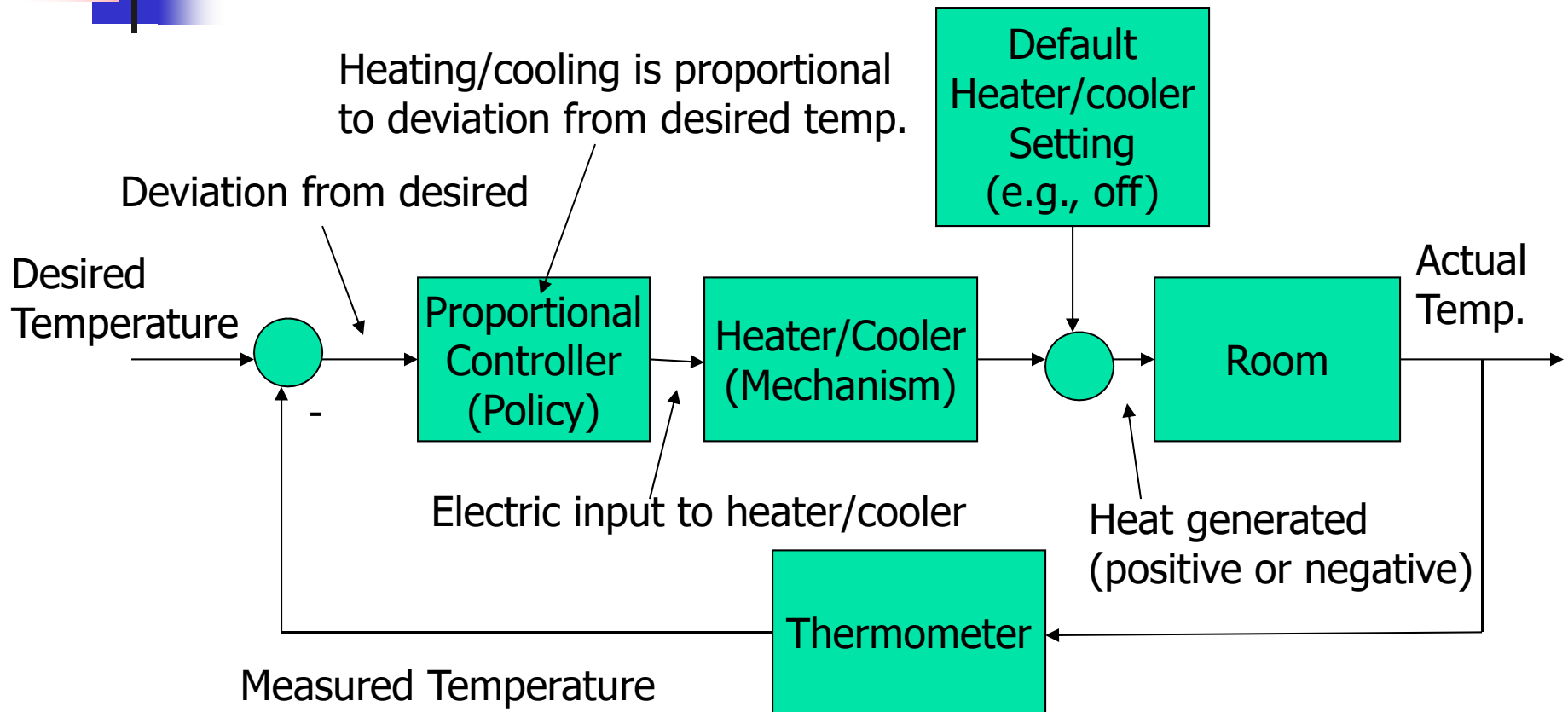

Chip Temperature Feedback Control

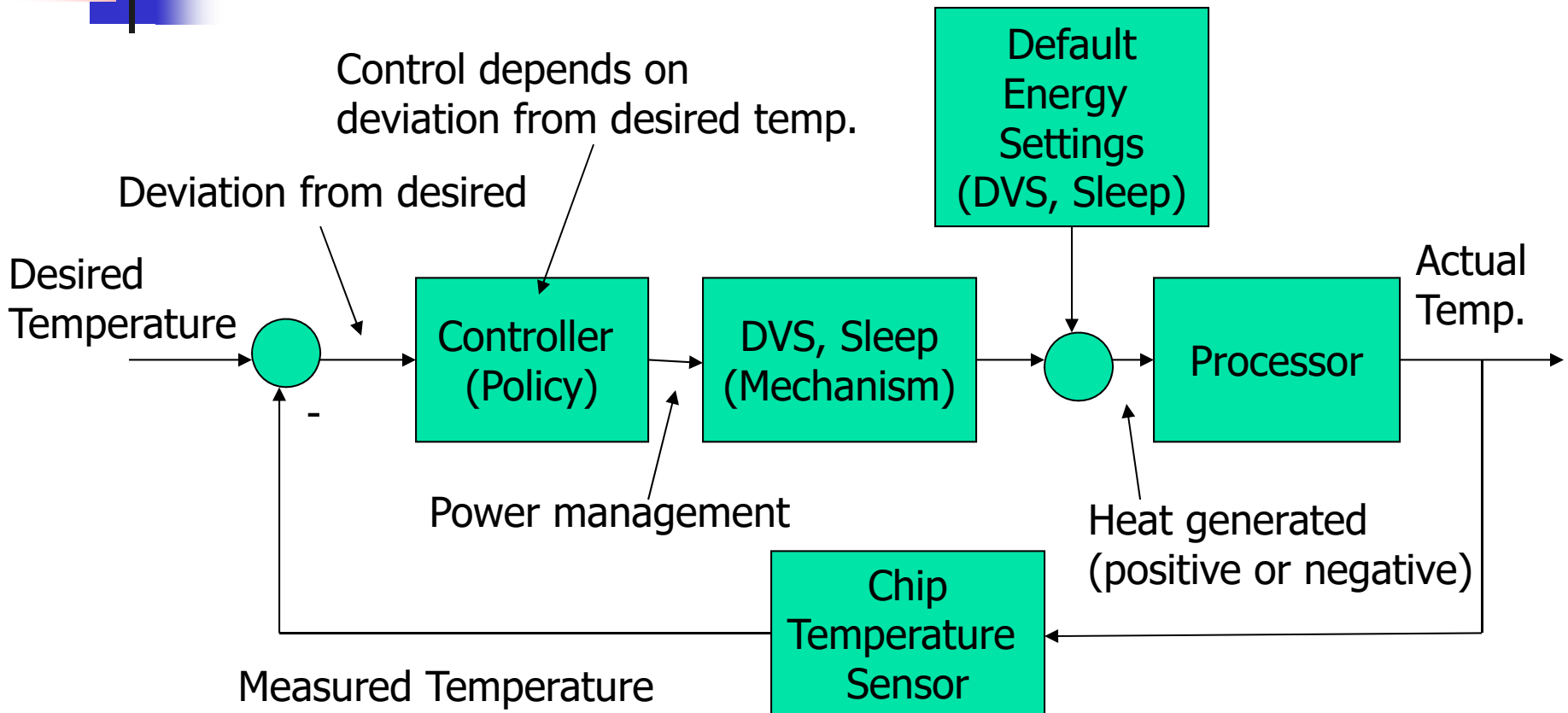

Feedback Design Concern #1: Stability

Will the loop converge?

- Must prevent over-compensation

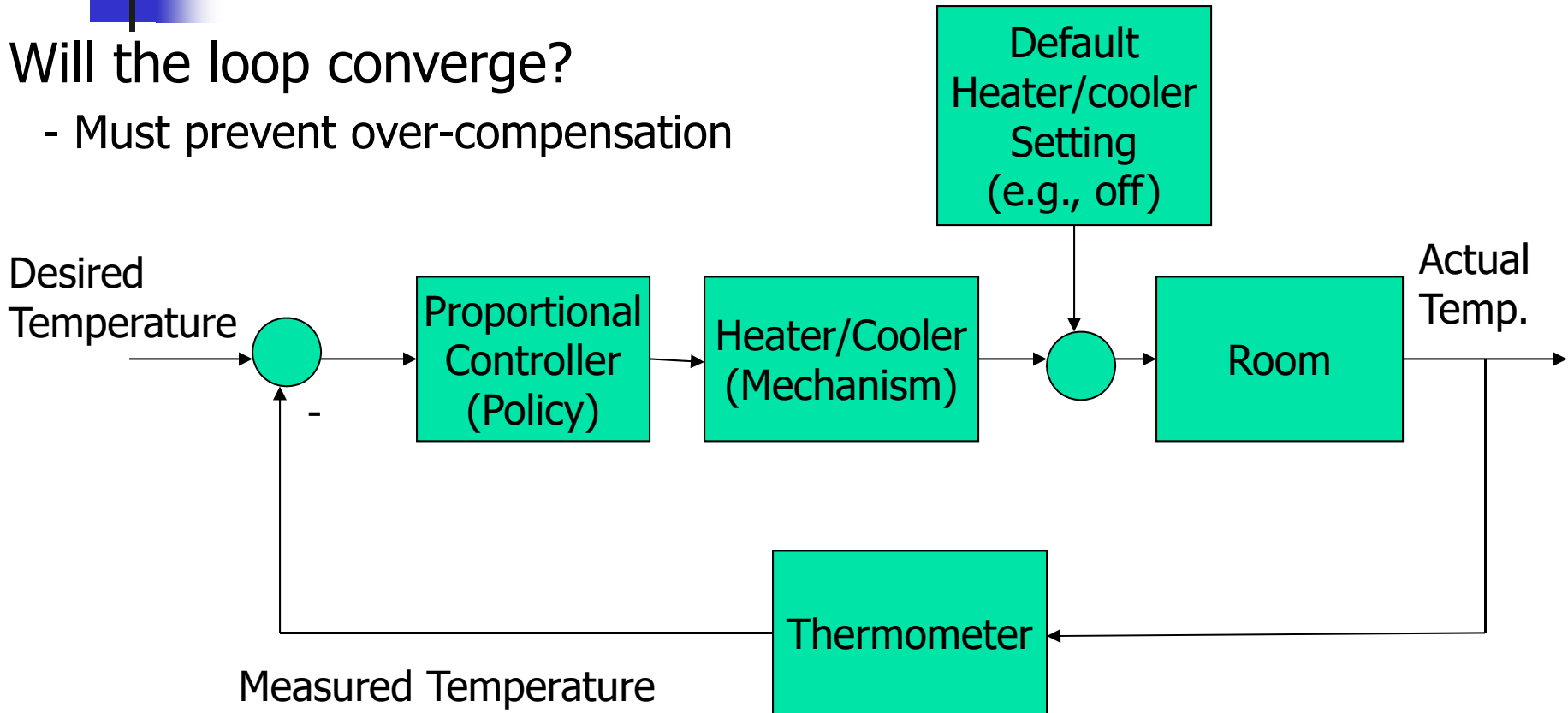

Feedback Design Concern #2: Steady State Error

Will the loop converge exactly to the desired set point?

- Depends on the control policy

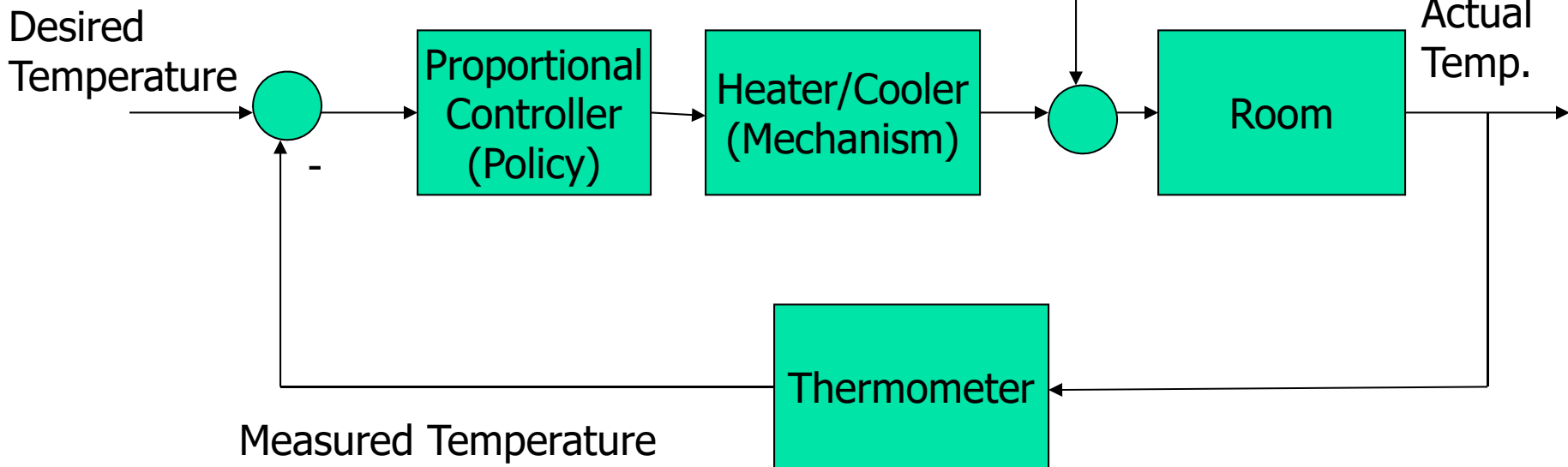

Stability

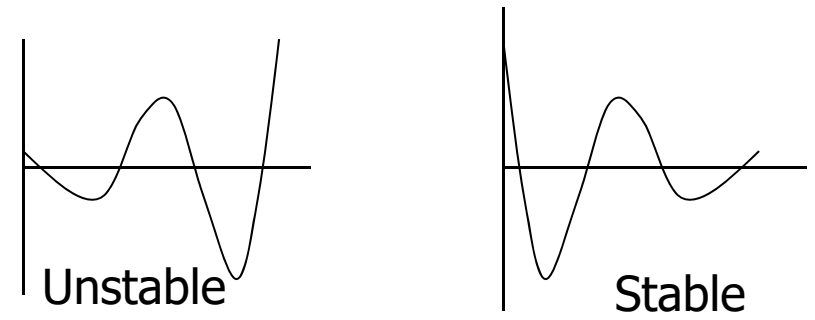

Intuition: Loop must not magnify signals
(loop gain < 1)

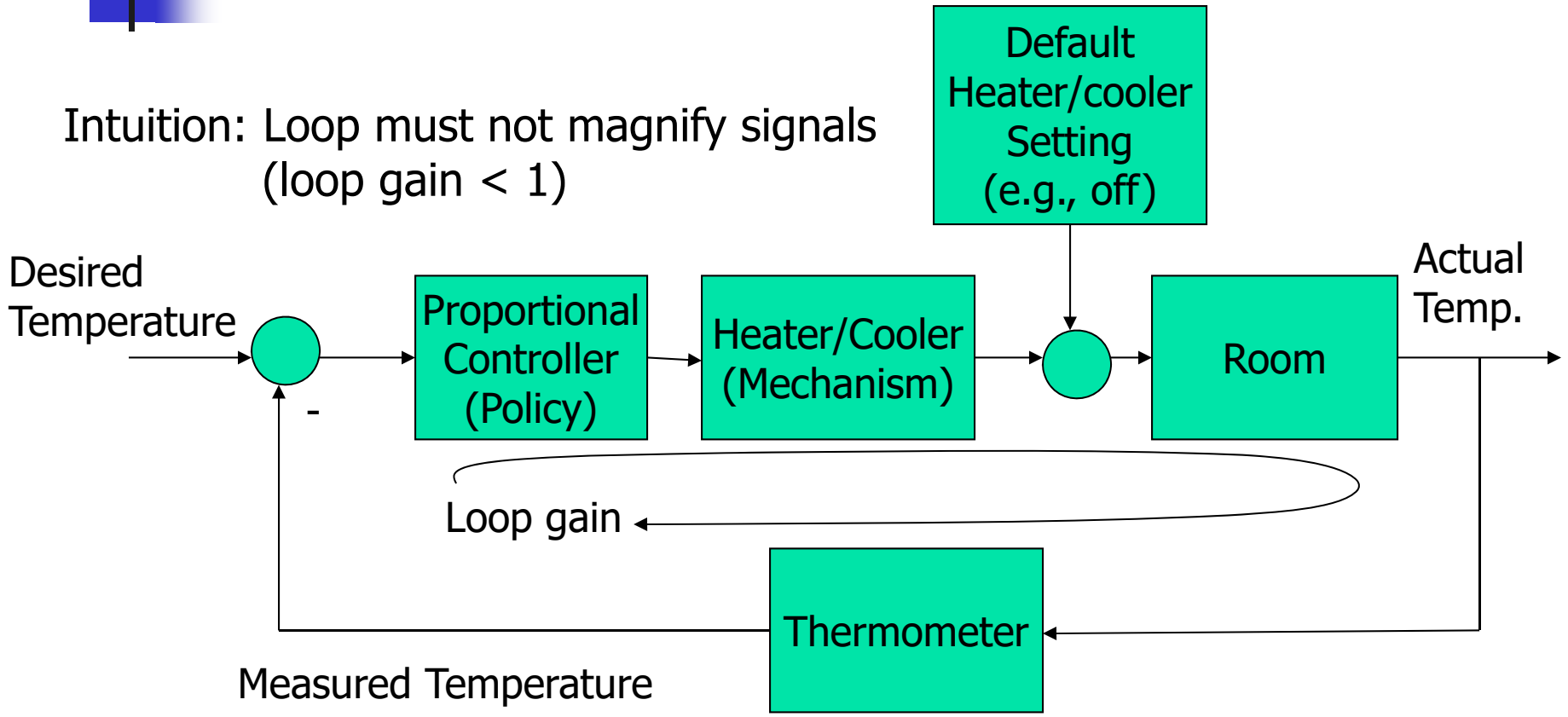

Stability Example

Is the loop below stable?

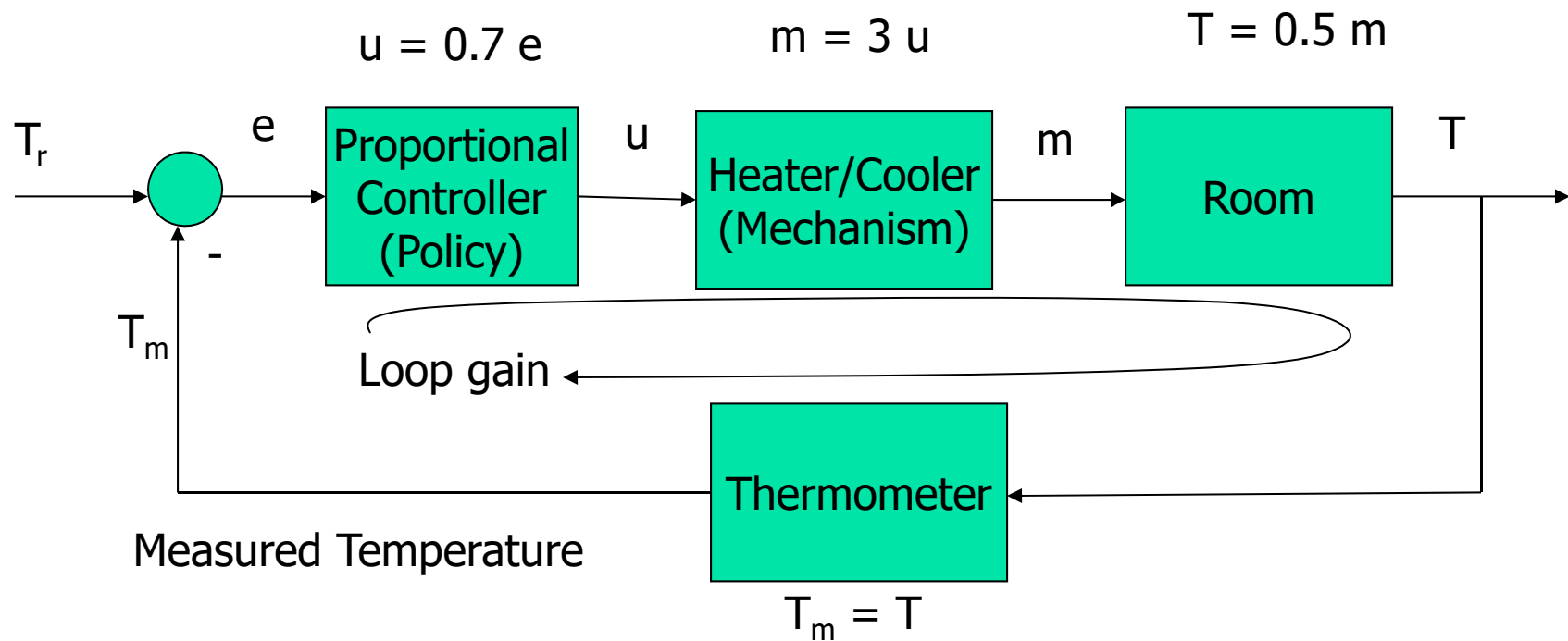

Stability Example

Is the loop below stable?

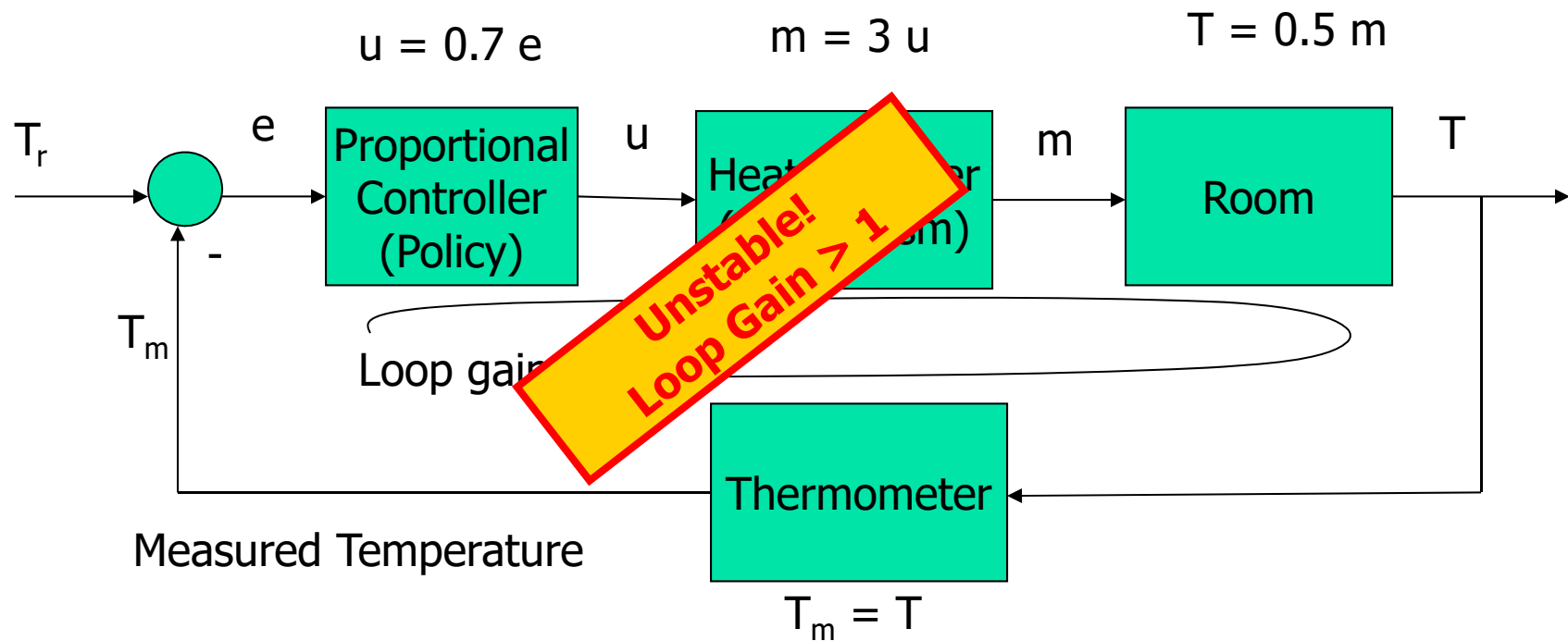

Stability and Phase Shift

- Fact 1: Most reactions are not instantaneous

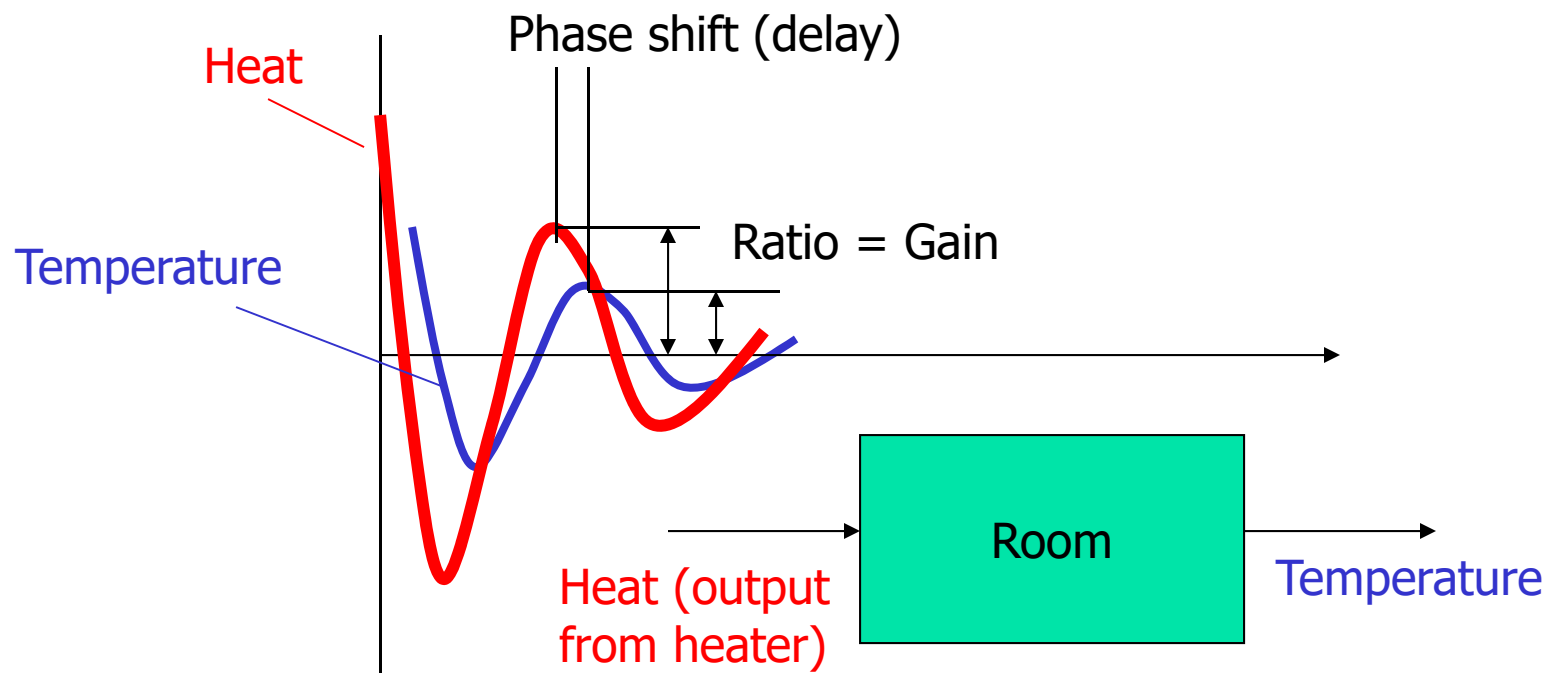

Stability and Phase Shift

- Fact 2: Gain and phase shift depend on frequency

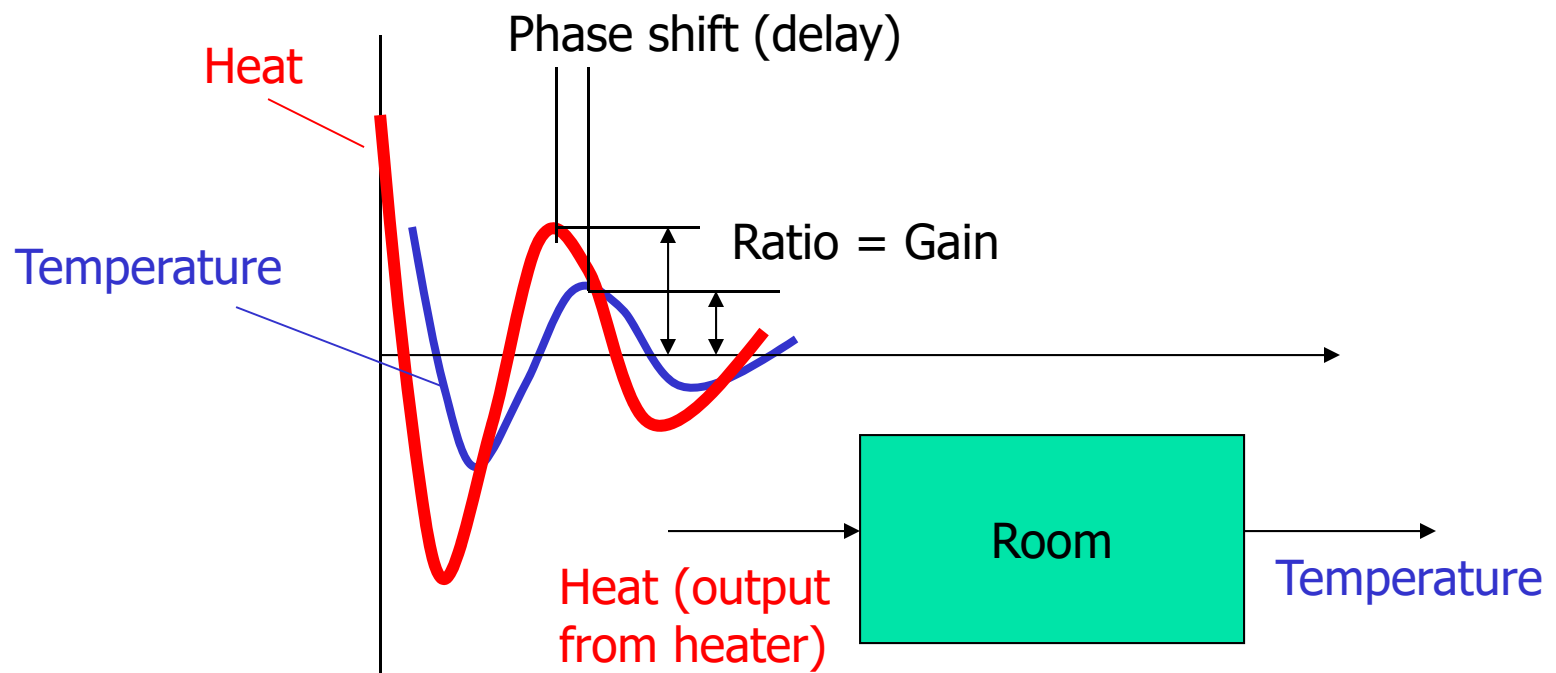

Stability and Phase Shift

- Fact 2: Gain and phase shift depend on frequency

Example:

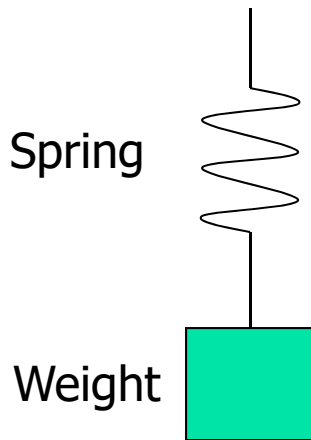

↕ If you hold the top of the spring and move 1 ft up then 1 ft down at an increasing frequency, what happens to the range of motion of the weight?

Stability and Phase Shift

- Fact 2: Gain and phase shift depend on frequency

Example:

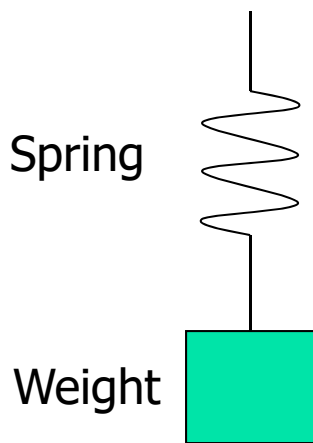

↕ If you hold the top of the spring and move 1 ft up then 1 ft down at an increasing frequency, what happens to the range of motion of the weight?

Gain $g(f)$ Answer: Range of motion of weight decreases as frequency increases

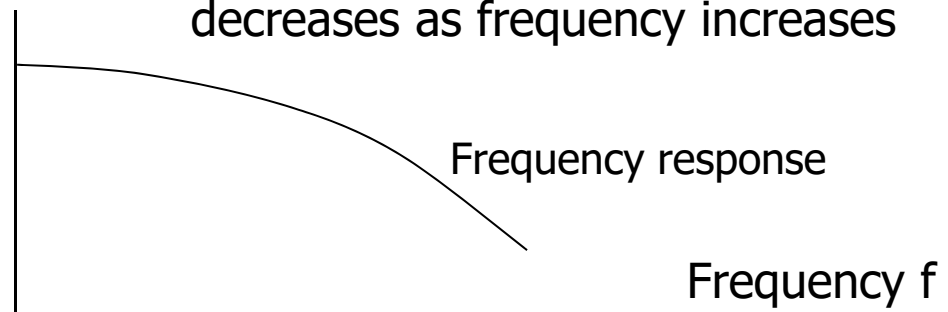

Stability and Phase Shift

- Fact 2: Gain and phase shift depend on frequency

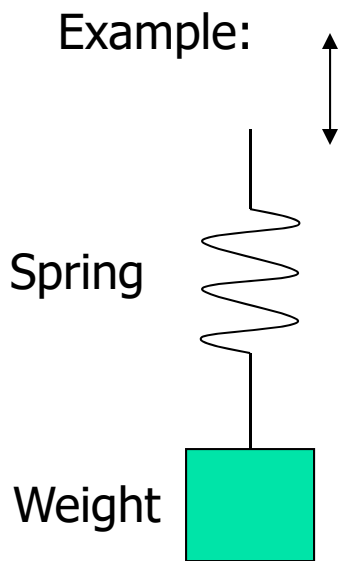

Also, the weight grows more "out of sync" with you (lags behind).
That is to say, phase shift increases

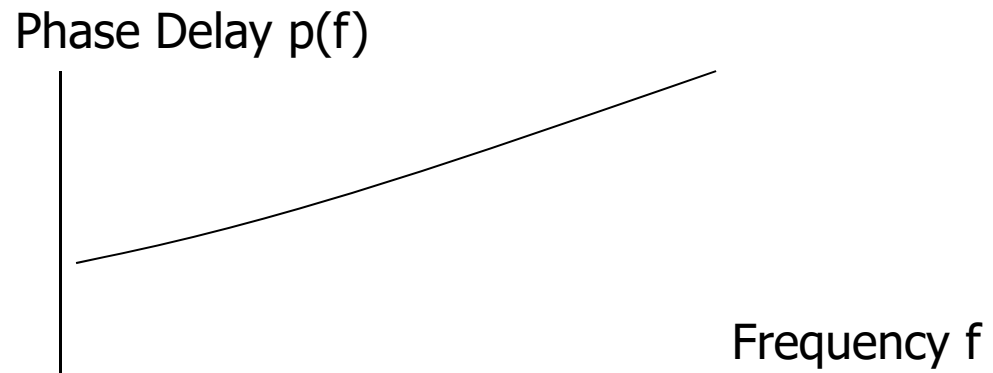

Stability Example Revisited

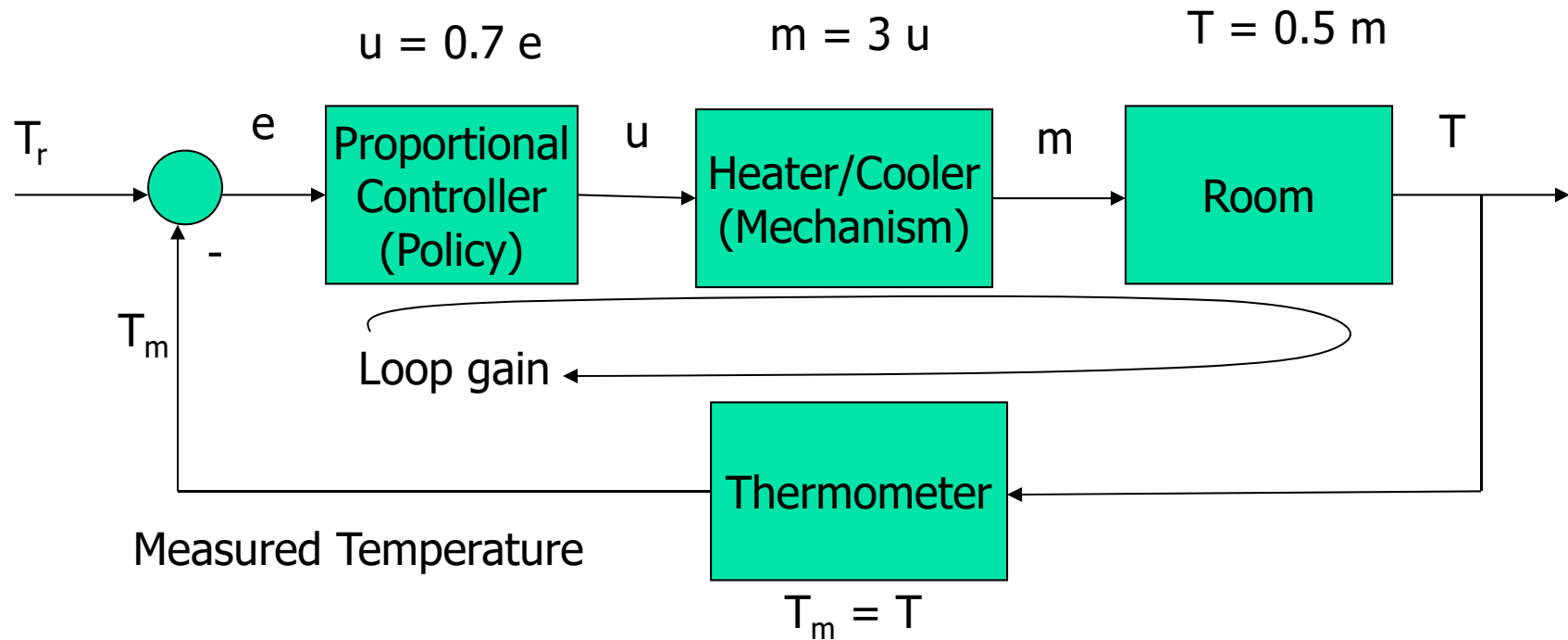

Stability Example Revisited

Which frequency f to consider?

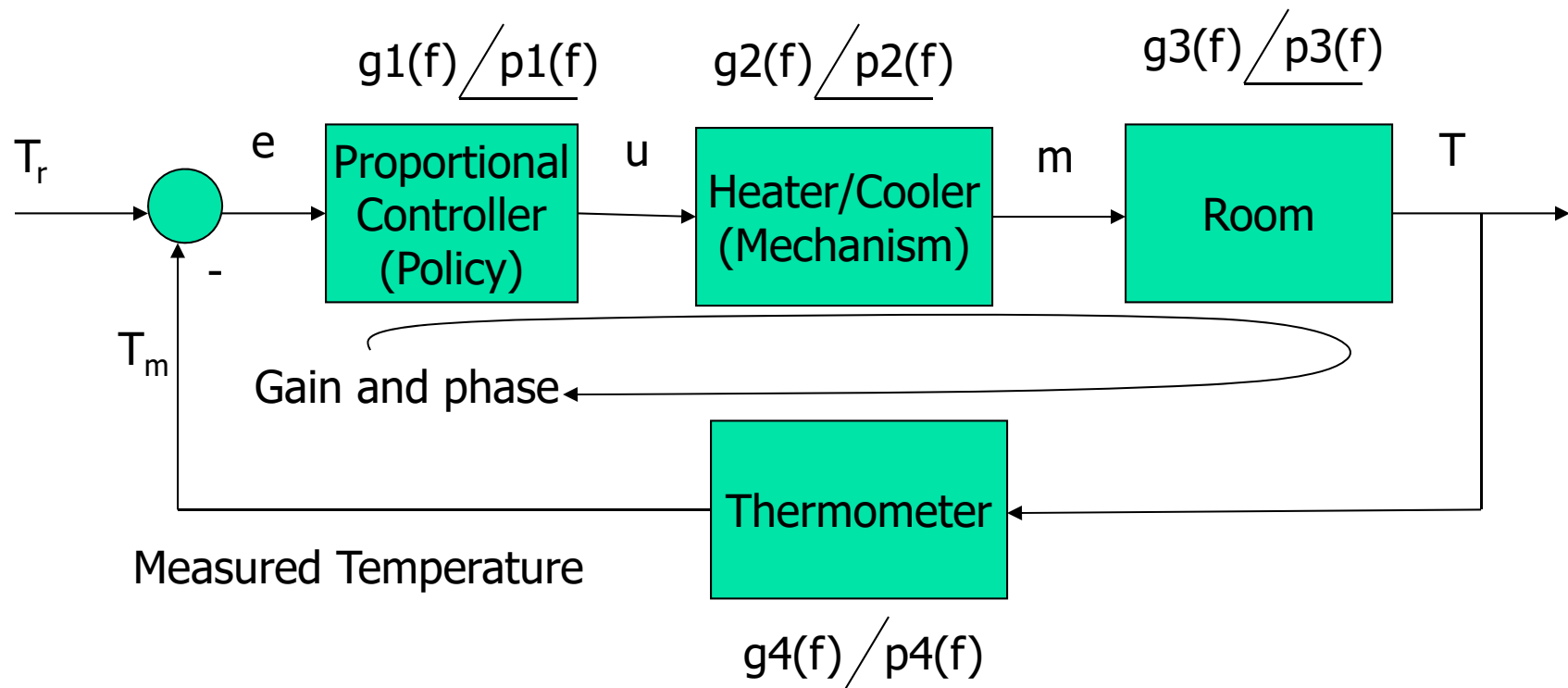

Stability Example Revisited

Which frequency f to consider?

Answer: The one that makes the sum of $p_i(f) = 180^\circ$ (why?)

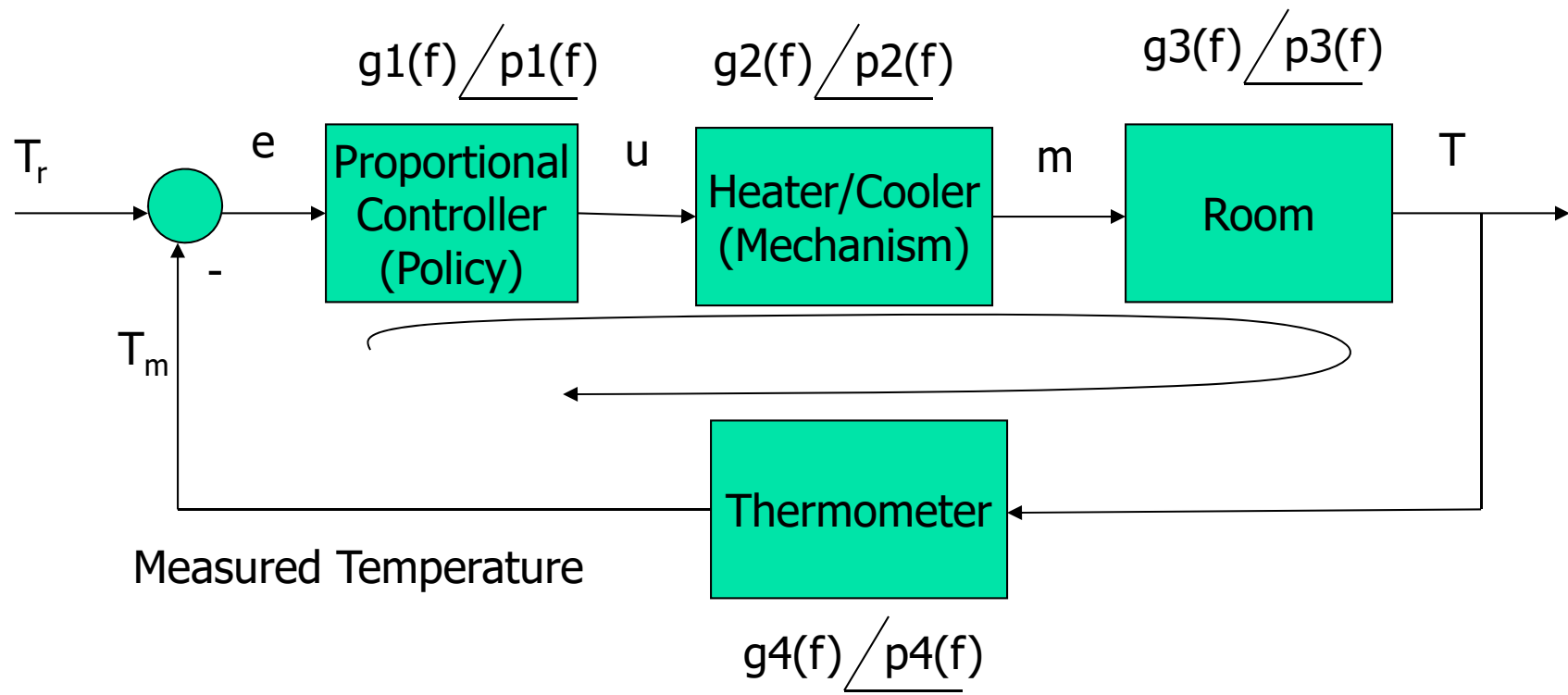

Stability Example Revisited

Phase equation: $\sum_i p_i(f) = \pi$ \longrightarrow f is obtained

Gain equation: $\prod_i g_i(f)$ must be less than 1 for stability

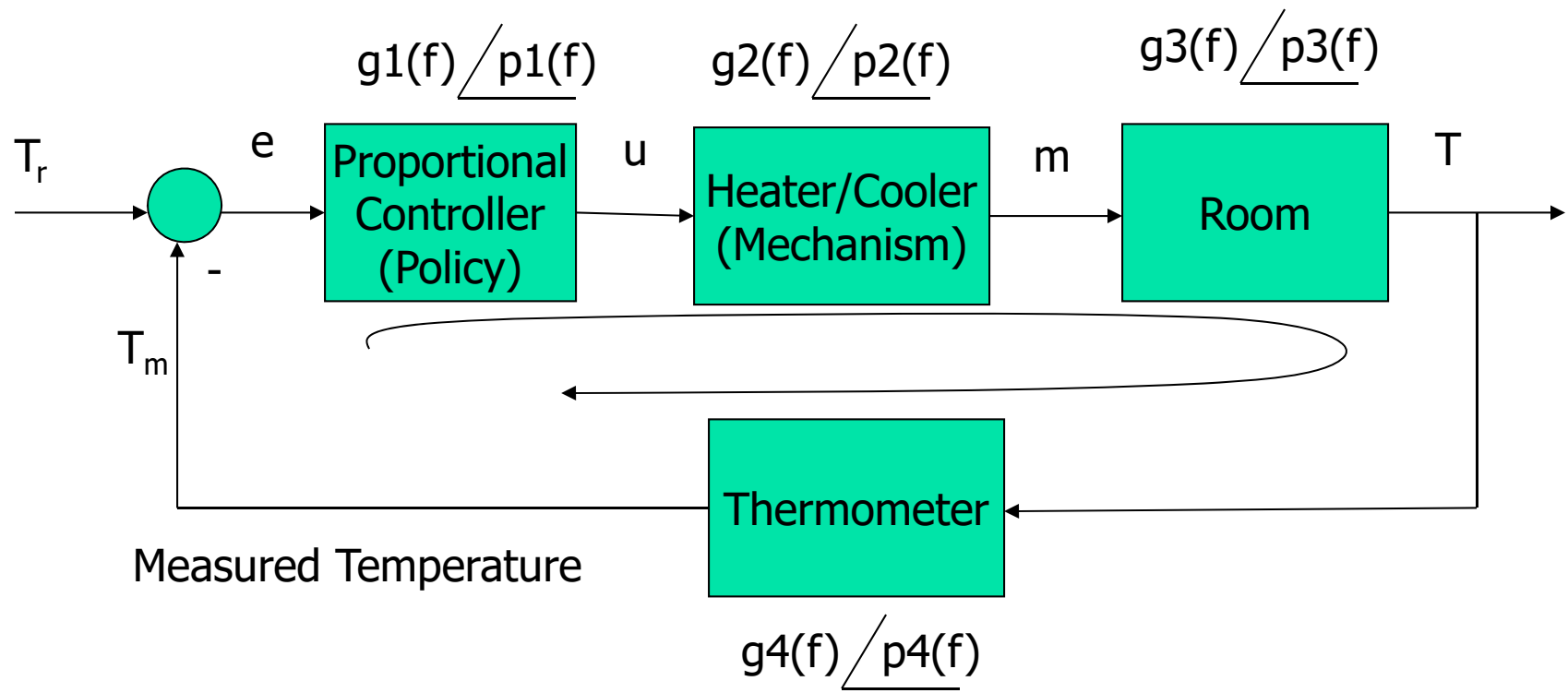

Computing the Transfer Function



- Example 1: Find gain and phase of an integrator? Hint: substitute for input with $\sin(\omega t)$, and compute output, then determine gain and phase shift.



Computing the Transfer Function

- Example 1: Find gain and phase of an integrator?

- Observation: The integral of $\sin(\omega t)$ is $-\cos(\omega t) / \omega$
 - Gain = $1/\omega$
 - Phase = -90°

Computing the Transfer Function



- Example 2: Find gain and phase of a differentiator?



Computing the Transfer Function

- Example 2: Find gain and phase of a differentiator?

- Observation: The derivative of $\sin(\omega t)$ is $\omega \cos(\omega t)$
 - Gain = ω
 - Phase = 90°

Computing the Transfer Function



- Example 3: Find gain and phase of a pure delay element?

Computing the Transfer Function



- Example 3: Find gain and phase of a pure time-delay element?
- Observation: Delay does not magnify signal. Phase shift is equal to proportional to frequency and delay
 - Gain = 1
 - Phase = $-w D$

Computing the Transfer Function

- Example 4: Find gain and phase of an element given by the first order differential equation below?

$$Output + \tau \frac{dOutput}{dt} = K Input$$

- Observation:
 - Gain = ?
 - Phase = ?

Computing the Transfer Function

- Example 4: Find gain and phase of an element given by the first order differential equation below?

$$Output + \tau \frac{dOutput}{dt} = K Input$$

- Observation:
 - Gain = K
 - Phase = $-\tan^{-1} \omega \tau$

Note: This element is called "first order lag". τ is called a time constant.

Summary of Basic Elements

Input = $\sin(\omega t)$

Element	Gain	Phase
Integrator	$1/\omega$	$-\pi/2$
Differentiator	ω	$\pi/2$
Pure delay element (Delay = D)	1	$-\omega D$
First order lag (time constant = τ)	$K / \sqrt{1 + (\tau \omega)^2}$	$-\tan^{-1}(\omega \tau)$
Pure gain (Gain = K)	K	0

Note:

$$\omega = 2 \pi f_{osc}$$

Where f_{osc} is
the loop
frequency of
oscillation

Steady State Error

At steady state the system "catches up" – phase shift is zero.

$$T_r - e \cdot g_1(f) \cdot g_2(f) \cdot g_3(f) \cdot g_4(f) = e \quad e = \frac{T_r}{1 + \prod_i g_i(f)}$$

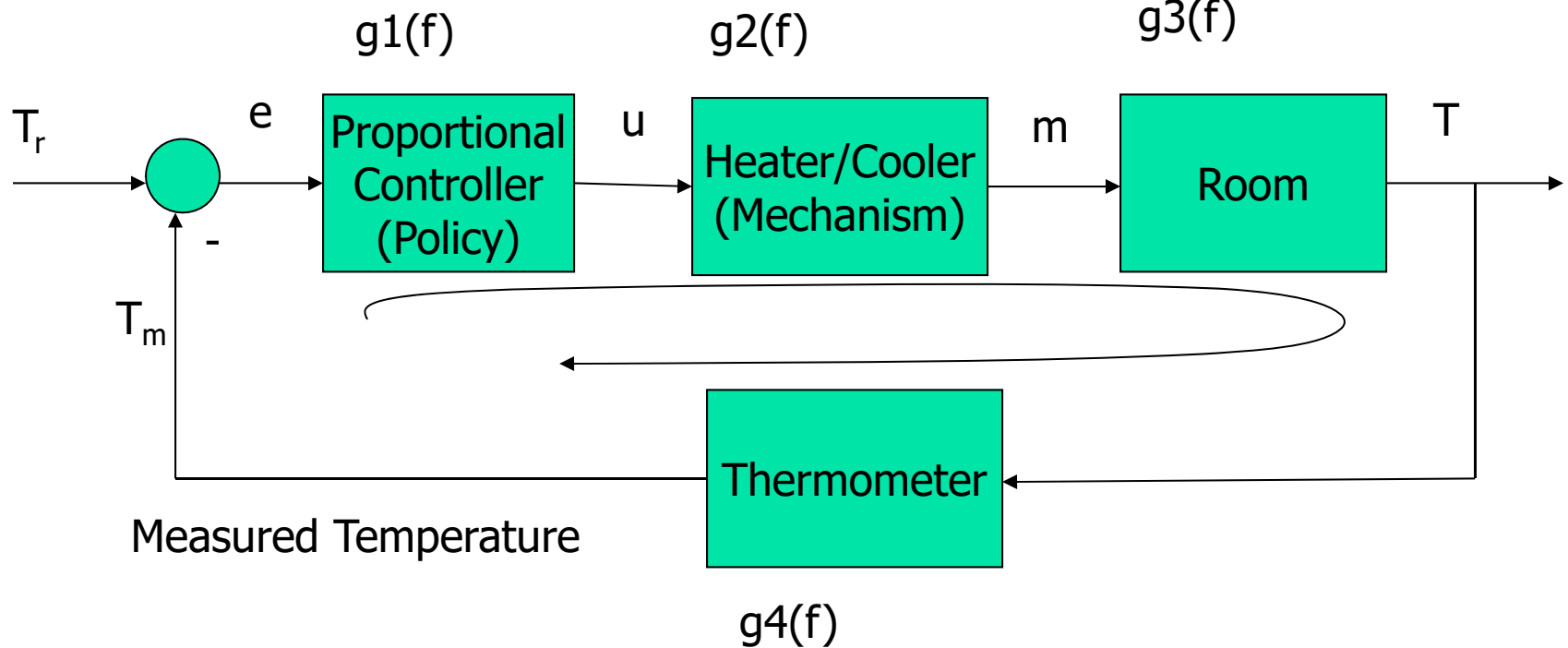

Steady State Error

Loop must contain an integrator for the steady state error to be zero.
(Why?)

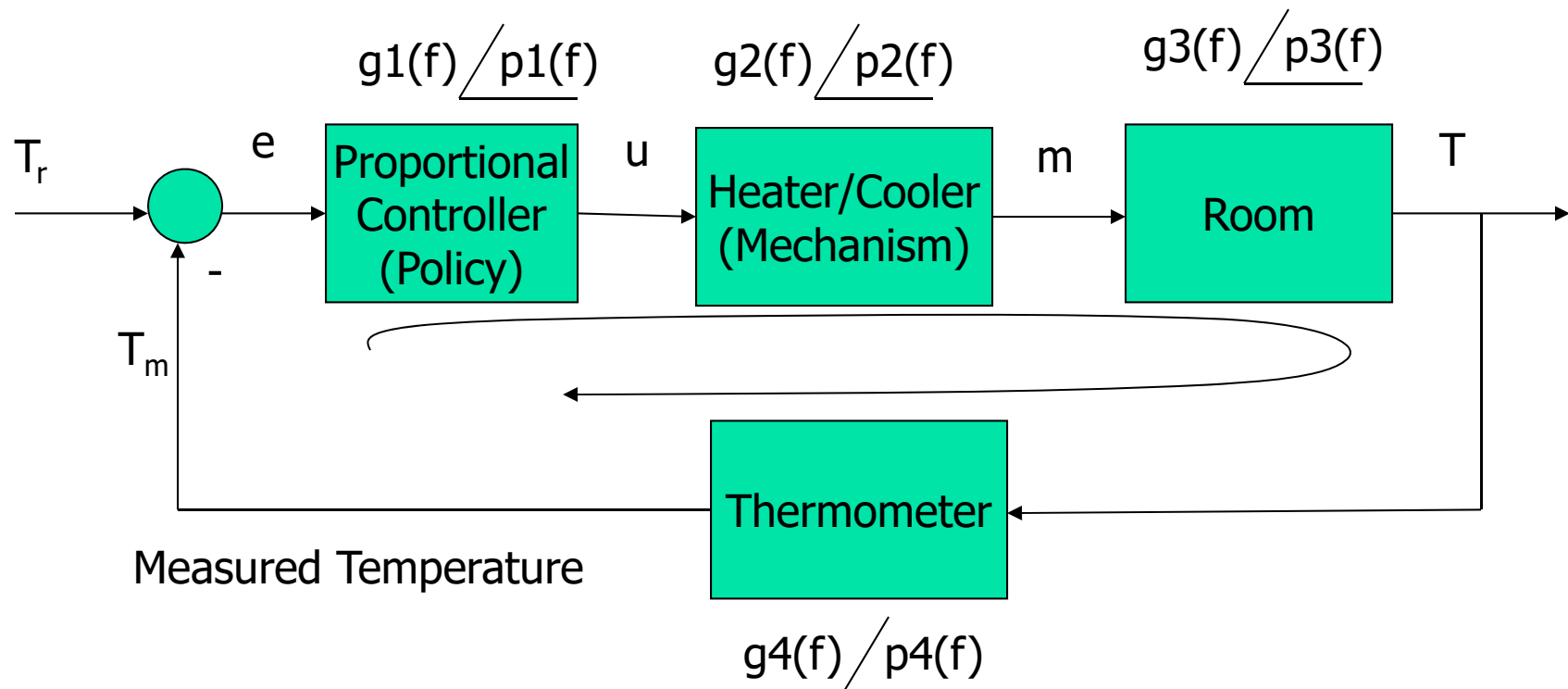



Example

- A robot has a side sensor that can measure distance from a wall when the robot is traveling roughly parallel to it (a short distance away). The operator can control the wheels to turn the robot towards or away from the wall. Design a control loop that keeps the robot traveling along the wall a constant distance away (without bumping into it and without straying away). Wall can be a curved surface.



Example

- When a processor executes a task, its temperature increases with normalized frequency, f , with a time constant = 1 minute. An increase of 0.1 in f causes a temperature increase of 3 degrees. An on-chip sensor reports temperature with a 10 second delay. Design a frequency controller such that processor temperature stays at or around 80 degrees.



Example

- When a processor executes a task, its temperature increases with normalized frequency, f , with a time constant = 1 minute. An increase of 0.1 in f causes a temperature increase of 3 degrees. An on-chip sensor reports temperature with a 10 second delay. Design a frequency controller such that processor temperature stays at or around 80 degrees.
- How would your design change if the energy-optimal frequency of the processor was 0.5?



Example

- When a processor executes a task, its temperature increases with normalized frequency, f , with a time constant = 1 minute. An increase of 0.1 in f causes a temperature increase of 3 degrees. An on-chip sensor reports temperature with a 10 second delay. Design a frequency controller such that processor temperature stays at or around 80 degrees.
- How would your design change if the energy-optimal frequency of the processor was 0.5?
- How would your design change if in addition the processor executed real-time tasks using RM?



Example

- When a processor executes a task, its temperature increases with normalized frequency, f , with a time constant = 1 minute. An increase of 0.1 in f causes a temperature increase of 3 degrees. An on-chip sensor reports temperature with a 10 second delay. Design a frequency controller such that processor temperature stays at or around 80 degrees.
- How would your design change if the energy-optimal frequency of the processor was 0.5?
- How would your design change if in addition the processor executed real-time tasks using RM?
- Does your control loop ensure zero steady state error? If not, redesign.



Example

- When a processor executes a task, its temperature increases with normalized frequency, f , with a time constant = 1 minute. An increase of 0.1 in f causes a temperature increase of 3 degrees. An on-chip sensor reports temperature with a 10 second delay. Design a frequency controller such that processor temperature stays at or around 80 degrees.
- How would your design change if the energy-optimal frequency of the processor was 0.5?
- How would your design change if in addition the processor executed real-time tasks using RM?
- Does your control loop ensure zero steady state error? If not, redesign.
- What is the effect of sensor delay on frequency of oscillation?