

# Pet Selective Automated Food Dispenser

---

By  
Advika Battini  
Ali Yaqoob  
Vibhu Vanjari

TA: Yuchen He  
Team Number: 46

Proposal for ECE 445, Senior Design,  
Spring 2018, University of Illinois Urbana Champaign  
8 February 2018

# 1 Introduction

## 1.1 Objective

The goal of this project is to regulate the amount of food each pet eats. Pet owners often lead busy lives and sometimes two or more pets can be more of a hassle than expected. A lot of times one pet eats the other pet's food causing problems to both pets' health. This device will properly identify which pet is approaching the dispenser and consequently dispense the right amount of food. The food will only be accessible to the right pet at the right time; the dispenser can be programmed to dispense food at particular times of the day. The system can be applied to a wide variety of animals but for simplification purposes we will be building a cat food dispenser.

## 1.2 Background

Inspiration to create this device came from one of our friend, who was facing a "fat-cat-skinny-cat" situation at home. One of the cats would finish its food quickly and proceed to eat the other cat's food as well. This caused one cat to be obese, while the other cat lacked necessary nutrients. A recent report showed that 24% of the cats owned as pets in the US are overweight. [1]

Currently the pet ownership in US households stands at 55%. About 59 million Americans own cats and about 50% of cat households own multiple pets; two or more cats, cats and dogs. The increasing trend in multi-pet households creates a demand for a wholesome food scheduling system. [2]

Available products in the current market that address this problem are mainly of two types. Type one, these products are basically food dispensers that can be timed so your pet is fed only at a particular time. While this does not solve the multi-pet problem it helps busy pet owners to feed their pets in a timely fashion. Type two, these are pet food bowls that come with a closing-lid mechanism. If the right pet comes to the bowl, the door opens and the pet can eat its food. If the wrong pet come to the bowl, it cannot access the food. This solves half, the problem but the pet-owner has to pre-place the food in the bowl. Our solution will combine these two features.

## 1.3 High-Level Requirements

- The food dispenser must be able to distinguish between two or more different cats using RFID/Microchip.
- The food dispenser must be able to dispense pre-programmed amounts of food at specified times for each cat.

- The food dispenser must notify the owner on the LCD display when the food in the dispenser storage is low.

## 1.4 Aspirational Goals

- The food dispenser must be able to monitor how much food each cat is eating and communicate wirelessly with the owner by sending weekly updates on the cat's food intake
- The food dispenser must include a sound feature that can grab the pets' attention during meal time

## 2 Design

### 2.1 Block Diagram

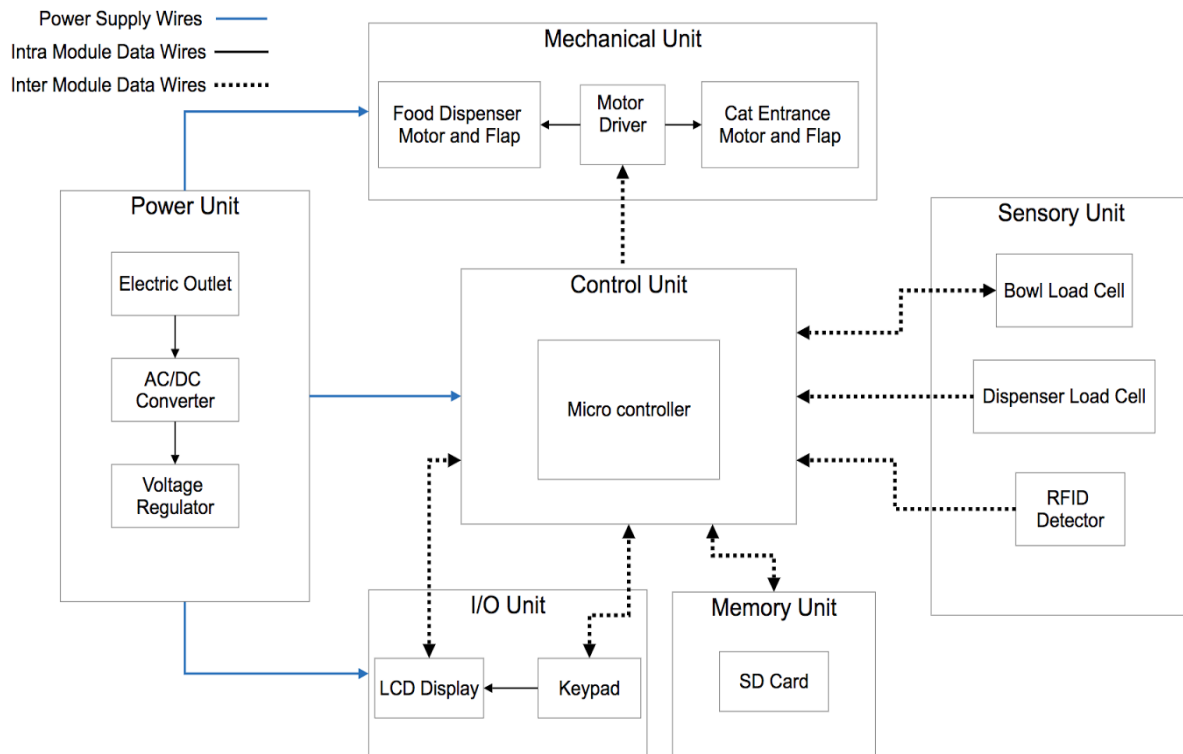

Figure 1: Block Diagram of the Pet Selective Food Dispenser

## 2.2 Physical Design

Physically, the main goal of our device's design is to be able to withstand moderate amounts of force in order to prevent it from toppling onto the pets. Our mechanical structure will emphasize on sturdy design and will use materials like plastic and metal, prohibiting the pet from being able to move it around or break it. Another major concern regarding the pet feeders in the market is that they contain rubber parts that are not durable and also cause pets to choke. Our design will properly seal away all small, hazardous and chewable parts to avoid this. A possible design for the dispenser is depicted below.

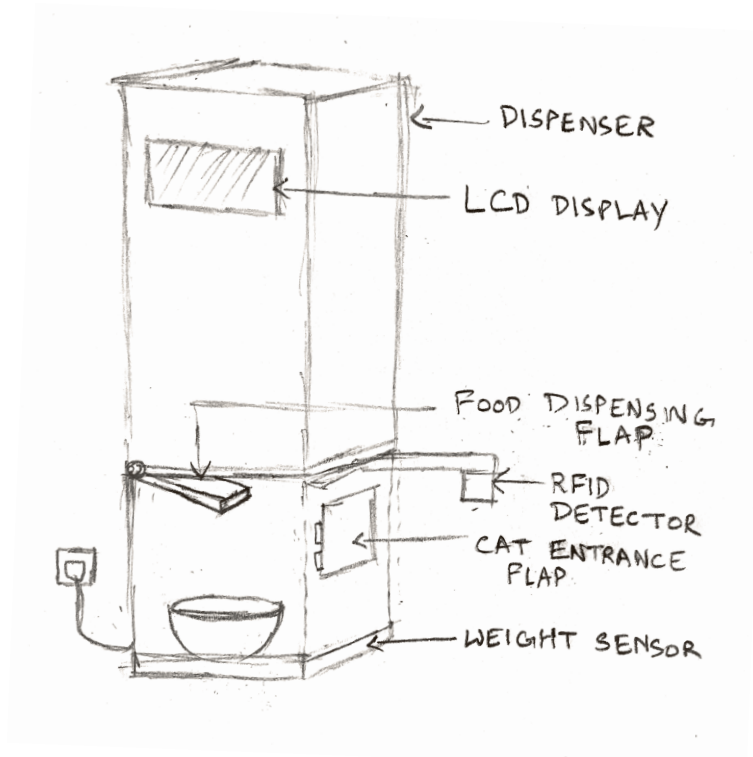

Figure 2: Pet Selective Food Dispenser Design Sketch

## 2.3 Functional Overview

### 2.3.1 Sensory Unit

The sensory unit will function as the feedback and input unit to the control unit. It will interface with the environment and send signals to the control unit.

#### 2.3.1.1 RFID/Microchip Detection

The microchip in the cat will be read by the RFID reader with a range of 5-7 cm, detecting when the right or wrong cat is approaching. [3] The microchip will be placed on a ledge protruding out

of the dispenser as depicted in Figure 2. This will give the microchip detector the best chance of detecting a cat moving towards the food.

*Requirement 1: Since most pet microchips in the US operate at 125kHz, our detector should have a resonant frequency of 125kHz.*

*Requirement 2: The range of the detector should be greater than 5cm. We plan on optimizing our design to have detection accuracy of at least 90%.*

*Requirement 3: Must operate between 10-200mA.*

### **2.3.1.2 Low Food Weight Detection**

A weight sensor (dispenser load cell) at the bottom of the dispenser will determine the amount of cat food left in the system. It will notify the owner when the food level is below a certain weight.

*Requirement: Range of 0-3 Kg, a precision of at least 2% of full scale, and at most  $\pm 0.5\%$  error tolerance.*

### **2.3.1.3 Food Consumption Weight Detection**

A second weight sensor (bowl load cell) will determine the amount of food dispensed into the bowl and detects when most of the food is eaten. Potentially, the output of the sensor will be used to determine the amount of food the different cats eat over a period of time.

*Requirement: Range of 0-300 g, a precision of at least 1% of full scale and at most  $\pm 0.1\%$  error tolerance.*

## **2.3.2 Control Unit**

The control unit will function as the brain of our device. It will process signals from from the different sensors and I/O devices listed below and control the motors in the mechanical unit.

### **2.3.2.1 Microcontroller (ATmega328p) [5]**

The ATmega will be programmed using an Arduino and fixed onto a PCB. The ATmega will process the signals from the microchip detector and weight sensors and output signals to the motors to open and close the gates.

First the user will input the time he/she wants the cats to be fed, this will be compared to the time to determine when the flaps are opened. An algorithm will account for delays in signals from the weight sensor and signal to the motor drive to accurately dispense the right amount of food.

The dispenser weight sensor will be refreshed each time food is dispensed. When the amount of cat food in the dispenser is below the threshold value the controller will send a signal to the LED to light up indicating low food.

The controller will simultaneously process the microchip detector signals to allow/disallow the cat approaching the feeder to eat.

*Requirement 1: Should be able to process at least 2 analog and 10 digital signals simultaneously.*

*Requirement 2: Can process signals to output a PWM for the motor drive.*

*Requirement 3: Should be able to operate at industry standard voltages such as 3.3V and/or 5V.*

### 2.3.3 Mechanical Unit

The mechanical unit consists of flaps that open and close based on the signals sent from the control unit. To reduce power consumption, we plan on powering the motors only when we need to open the flaps and reduce idle state power losses.

#### 2.3.3.1 Motor Drive

The motor drive regulates the power supplied to the motors moving the food dispensing flap and cat entrance flap. The motors are the parts consuming the most power and must be protected from risky situations. The drive also powers the right motor to open/close the flaps depending on the signal sent from the microcontroller.

*Requirement 1: The drive must be able to protect motors from current spikes*

*Requirement 2: The drive must process the relay signals quick enough to dispense accurate quantities of food.*

#### 2.3.3.2 Food Dispensing Flap Motor

This motor controls the flap located inside the food dispenser. It will open and close the flap in brief intervals of time to dispense a certain quantity of cat food.

*Requirement 1: Must be a DC motor capable of rotational motion.*

*Requirement 2: Should not draw too much current.*

*Requirement 3: Should be able to provide enough torque to hold up 3kgs of cat feed.*

#### 2.3.3.3 Cat Entrance Flap Motor

This motor controls the flap located on the outside of the food bowl chamber. It is meant to open and close accordingly to allow/disallow a cat from eating the dispensed food.

*Requirement 1: Must be a DC motor capable of rotational motion.*

*Requirement 2: Should not draw too much current.*

*Requirement 3: Should be able to provide enough torque to hold up against a 5kg cat.*

### 2.3.4 I/O Unit

The I/O unit acts as the interface between the cat owner and control unit. This unit will take in the dispense times and weights from the owner and also notify the owner when the cat food level is low.

#### 2.3.4.1 LCD Display

A simple LCD screen that will display the selected times while they are inputted by the keypad. It serves as visual confirmation to the user (owner). The screen will indicate to the owner when to input values. The display will also consist of an LED to notify the owner when the food level is low.

*Requirement 1: The LCD screen should be able to display at least 10 characters at a time.*

*Requirement 2: The low food indicator LED should turn on when the food level in the dispenser is below 300g.*

#### 2.3.4.2 Keypad

A device that can accept input such as number of cats, daily food consumption of each cat, number of meals per day etc. from the owner of the pets.

*Requirement 1: The keypad must have at least 5 buttons (4 arrows and enter key).*

*Requirement 2: The keypad should be hard to access for the cat.*

### 2.3.5 Memory Unit

The memory unit stores any information required in the future.

#### 2.3.5.1 SD Card

This unit comprises of SD card that will store information provided by the owner about feed times, it could potentially store recent history on past food consumption of pets.

*Requirement 1: Capability to store up to 2 GB of data collected*

*Requirement 2: The SD card should have at least 5 Mbps read and write speed*

### 2.3.6 Power Unit

This unit will power all the sensors, motors and the microcontroller inside the device.

#### 2.3.6.1 Wall Outlet Power Adapter

The adapter must convert voltage from a common electrical outlet (120V 60 Hz AC) to a desired DC voltage.

*Requirement 1: Dependent on our choice of microcontroller and motors, the DC voltage output of 9V can be regulated to the operating voltages.*

*Requirement 2: The adapter must be able to power the two motors opening and closing flaps as well as the microcontroller and the sensors connected to it.*

### **2.3.6.2 Voltage Regulators**

Ensures that the power is regulated at a near constant value. The 9V coming from the adapter needs to be stepped down to 3.3V and 5V required for other units of the device. Consequently, voltages 3.3V, 5V and 9V will be available to use.

*Requirement 1: Should be able to provide the desired voltage with an error tolerance of  $\pm 5\%$ .*

*Requirement 2: Provides a stable DC voltage independent of load current, AC line voltage, and temperature variations of up to 125 °C.*

## **2.4 Risk Analysis**

A major hurdle in the project would be implementing highly responsive and accurate cat detection hardware. The microchip (RFID) is usually embedded in the neck of the cat behind its head. RFID detectors have a small range (1-3 inches) of detection. The cat would have to be close enough to the scanner in order for the device to work. Placement of the detector is of utmost importance for accurate and successful identification of the cat. We will also need to ensure that the physical design of the device is able to scan appropriately under different orientations of the RFID scanner. Since the main variable factor in our design is the cat itself, we will need to take into account unpredictable motions, different sizes and so on.

Another area of risk would be the food dispensing flap. The feedback from the load cell needs to be processed quickly enough to control the motor. The motor needs to be strong enough to support the weight of the the food in order to ensure that the flap can close appropriately and not dispense too much food.

## **3 Ethics & Safety**

In order to align ourselves with the IEEE Code of Ethics # 9 “to hold paramount the safety, health, and welfare of the public, to strive to comply with ethical design and sustainable development practices, and to disclose promptly factors that might endanger the public or the environment” [4], we must consider all parts of this project which might be injurious to the pet and/or people who come in contact with the device. Proper measures must be taken in order to overcome the potential issues that may arise.



Exposed wires and power components may be hazardous if the animal or a person comes in contact with them. There may also be small parts of the device that might come off and make the animal choke upon swallowing. The animal also has the potential of knocking over the device. We commit ourselves to following IEEE Code of Ethics #1, “to hold paramount the safety, health, and welfare of the public, to strive to comply with ethical design and sustainable development practices, and to disclose promptly factors that might endanger the public or the environment”[4] and will provide appropriate support and shielding in the design so that the components which have the potential of heating up or shocking are far from reach and the device is stable enough to not be knocked over by the cat. We will 3D print portions of the device that will allow us the flexibility in controlling aspects of our physical design which might be endangering.

If the device malfunctions, this could potentially lead to the pet not being able to eat and could potentially lead to it being starved. The owner must check the device every 24 hours to ensure it is working. This is not meant to be a device that should be used in the absence of an owner over a long period of time.

With all these considerations, we will also include a list of warnings and precautions that an owner must take in order to ensure the safety and product optimizations. These will include instructions on how to position the device and where to place it so that the device may not be disconnected from the power outlet and is not near any sources of water, as well as other precautions.

## References

- [1] The 2017-2018 APPA National Pet Owners Survey Debut  
[http://americanpetproducts.org/Uploads/MemServices/GPE2017\\_NPOS\\_Seminar.pdf](http://americanpetproducts.org/Uploads/MemServices/GPE2017_NPOS_Seminar.pdf)
- [2] United States Pet Population and Ownership Trends Report 2017  
<https://globenewswire.com/news-release/2017/07/17/1047437/0/en/United-States-Pet-Population-and-Ownership-Trends-Report-2017-Focus-on-Dogs-Cats-and-Other-Pets.html>
- [3] Arduino Forum - Project Guidance - RFID Reader For Pet Microchip  
<https://forum.arduino.cc/index.php?topic=303284.0>
- [4] IEEE Code Of Ethics  
<https://www.ieee.org/about/corporate/governance/p7-8.html>
- [5] ATmega328 - Summary Datasheet  
[http://ww1.microchip.com/downloads/en/DeviceDoc/Atmel-42735-8-bit-AVR-Microcontroller-ATmega328-328P\\_Summary.pdf](http://ww1.microchip.com/downloads/en/DeviceDoc/Atmel-42735-8-bit-AVR-Microcontroller-ATmega328-328P_Summary.pdf)