

Introduction

Problem: In recent years, the force of nostalgia has made the aesthetic of analog glitches increasingly popular, and they have found wide use in mediums such as music videos, live concert visuals, video editing, and even film. However, authentic analog glitch devices are made only by a small number of artisans who alter (or "bend") the circuitry of vintage video hardware to introduce these visual artifacts, making them inaccessible to general hobbyist visual artists, such as the VJs who make visuals for house shows on campus.

The cost of a unit generally ranges from \$300 to \$700, with resold units sometimes reaching over \$1,000. This is due both to the increasing rarity of the hardware they're built from and the small number of people who hand-make these devices. Even after placing an order, the turnaround time can be upwards of 6 months. Additionally, controls on these devices are abstruse, typically consisting of unlabeled switches and potentiometers. This makes operating them confusing and requires the user to carefully experiment with the controls in order to figure out how to dial in a visually appealing setting.

The niche nature of this field makes it ripe for innovation, most importantly in the way of making them more accessible to the general artistic community.

Solution: The overall goal of this project is to make a robust and easily manufacturable analog glitch device that can be digitally controlled, with an aim towards making them more accessible to hobbyists and people who are interested in analog video. Using a custom PCB design, we aim to replicate the functionality of both a normal and bent video enhancer. Additionally, the analog circuitry will be controlled digitally using a microcontroller to adjust various amplifier gains and reroute signal flow. This way, the device can be interfaced with a user-friendly controller, making it easier and more fun to play with video distortion.

To do this, we will design a video enhancement circuit with carefully designed "bends" built into the PCB. Digital-to-analog converters connected to a microcontroller will serve as the go-between for our analog circuit and an external controller, allowing digital control over parameters of both the enhancement and distortion functionality. The microcontroller and analog circuitry will both be powered by a DC power supply. The enhancement circuit will consist mainly of amplifiers which cleanly boost or attenuate elements of the composite video input, while the distortion circuit will consist of feedback lines which connect into the enhancement circuit to create interference and distortion. The glitches we aim to achieve in our design include "ringing", "rainbowing", "ghosting", and "tearing".

Visual Aid:

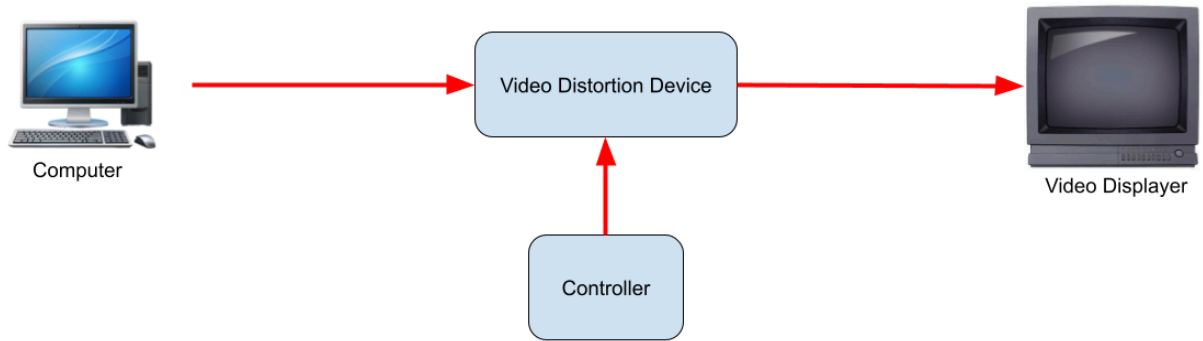

Fig 1: Simplified operational diagram



Fig 2: Examples of ringing feedback

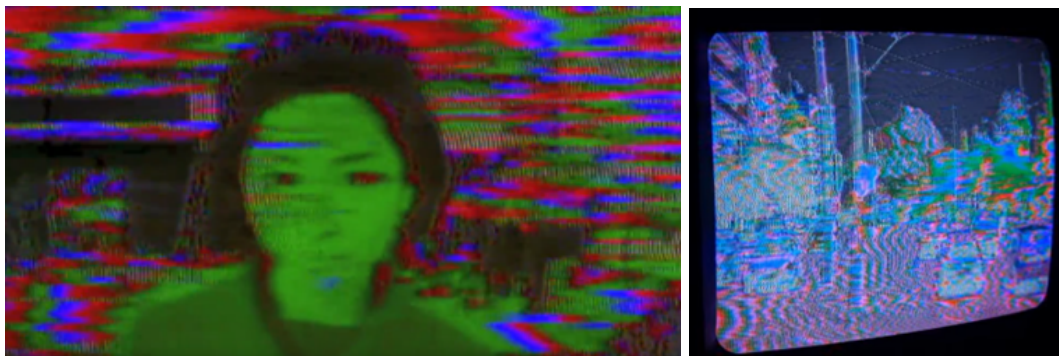

Fig 3: Examples of rainbowing



Fig 4: Examples of ghosting

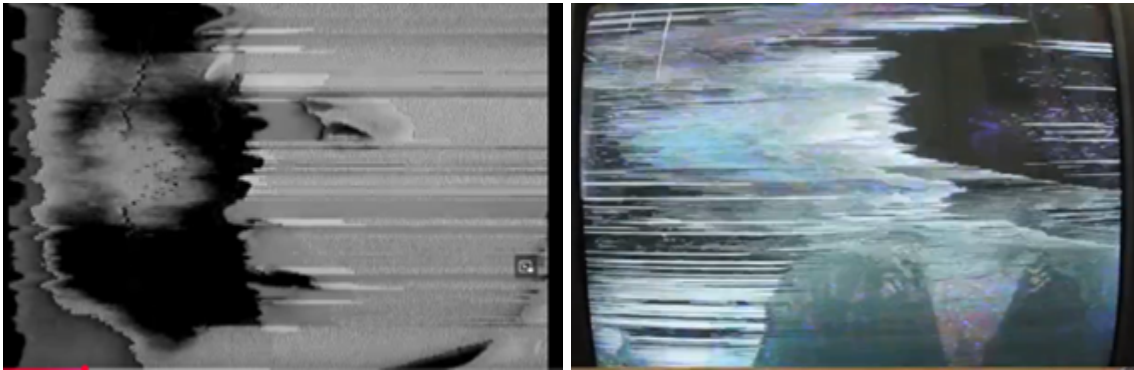

Fig 5: Examples of tearing

High-level requirements list:

- This device must be able to accurately enhance composite video signals without loss of fidelity.
- This device must be able to apply characteristic glitch distortion effects to the video signal.
- This device must be able to display the distorted video signal without signal dropout.
- This device must be able to be interfaced digitally by making use of a microcontroller.

Design

Block Diagram:

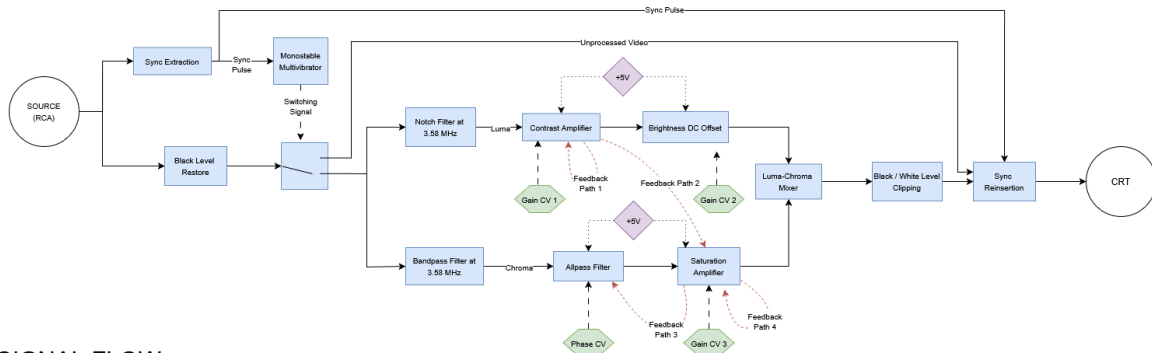

SIGNAL FLOW

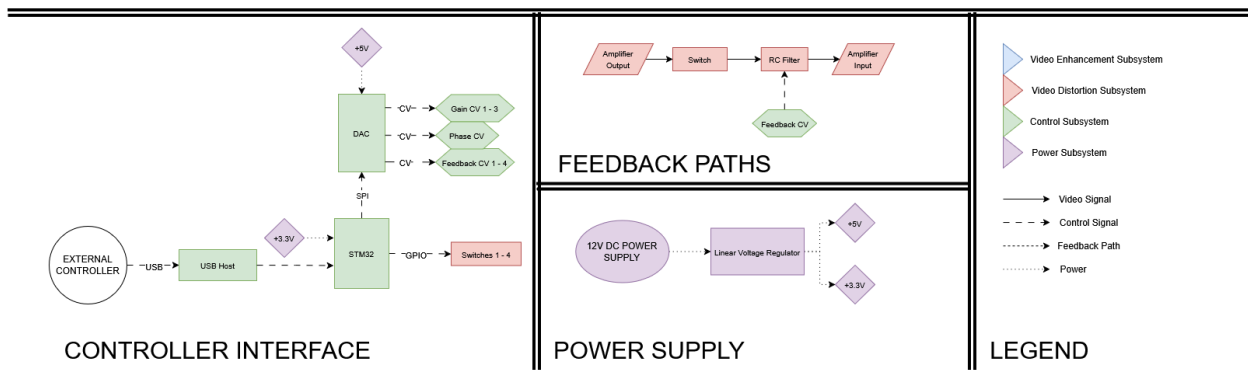

Subsystem Overview:

- I. **Video Enhancement Subsystem:** The video enhancement subsystem will be the heart of our design. It will be responsible for amplifying and altering parts of the video signal in order to modify qualities of the image such as contrast, brightness, and saturation. These parameters will be digitally controlled via the control subsystem. It will also protect the “housekeeping” parts of the signal (sync pulses, color burst) by periodically bypassing the amplification stage. The video distortion subsystem will hijack the enhancement circuitry using feedback loops to artfully introduce glitches into the image. Active circuit components will receive power from the power subsystem.
- II. **Video Distortion Subsystem:** This subsystem will be responsible for generating the glitches we aim to achieve from this device. It will function by interfering with the enhancement subsystem, introducing resonant feedback loops which cause oscillating interference in the image signal. The feedback gain and the subsystem activation will be controlled from the control subsystem using control voltage and digital switches, respectively. Active circuit components will receive power from the power subsystem.
- III. **Control Subsystem:** This subsystem will form the user interface of the device. The user will input digital control signals using a controller featuring knobs, buttons, and an LCD screen providing user feedback. These signals will be transmitted over USB to an STM32

microcontroller which will decode these signals into voltage levels or switching signals to be delivered to elements of the video enhancement and distortion subsystem. The MCU will communicate over SPI to several DAC ICs which will generate and deliver the specified voltages, and use GPIO to drive binary switches.

- IV. Power subsystem: The power subsystem will be responsible for powering all parts of the design. It will consist of a DC power supply which feeds into a linear voltage regulator. This regulator will provide a stable power supply to the MCU, controller, and analog circuitry.

Subsystem Requirements:

- I. Video Enhancement Subsystem: In order to function properly, the enhancement subsystem must be able to control the contrast, brightness, saturation, and hue of the image.
 - A. The contrast will be controlled by amplifying the luma component of the composite video signal, which encodes image brightness.
 - B. The brightness will be controlled by applying a DC offset to the luma signal, which will range from pure black to pure white.
 - C. The saturation will be controlled by amplifying the sinusoidal chroma subcarrier component, which encodes color, and the hue can be shifted by applying a phase shift.
 - D. To control these effects, control voltage will be delivered to the amplifier ICs from a DAC to control their gain.
 - E. In order to prevent amplifying or attenuating the sync pulses and color burst (which sets the reference phase of the chroma subcarrier), we will use a monostable multivibrator to send a switching signal which bypasses the amplifying circuitry during sync portions of the video signal.
 - F. In order to ensure the distorted image can be displayed on a CRT, the signal must be clipped at the voltage levels for pure black and pure white using op-amps.
- II. Video Distortion Subsystem: In order to introduce the glitches we aim to achieve, the video distortion subsystem must form feedback paths in the various amplifiers of the enhancement subsystem.
 - A. To control the quality of these glitches, the fed-back signal will pass through RC highpass and lowpass filters to achieve the ringing and ghosting effects, respectively. We will experiment with various feedback configurations to find visually appealing setups.
 - B. To control the strength of these effects, we will vary the amplitude of the fed-back signal. This can be done by either varying the resistance of a resistor in the RC filter network using a JFET as a voltage-controlled resistor, or by attenuating the fed-back signal using an active amplifier stage.

- III. Control Subsystem: In order to digitally control the parameters in the previous two subsystems, we must use a microcontroller to transform digital signals from an external controller to voltages supplied to points in the analog circuit.
 - A. To interface with a controller, we must either connect a pre-built controller to the MCU over USB, or build a custom controller which can communicate over a simpler protocol, such as SPI.
 - B. The MCU must then interpret the signals indicating changes in the positions of joysticks, knobs, or the press of a button and send signals to a DAC using SPI to tell it to change voltage levels in the analog circuitry.
- IV. Power Subsystem: Active circuit components must be supplied a steady supply voltage to ensure noise-free operation, and the MCU must receive sufficient power to power itself and the external controller.
 - A. We will use a 7V DC power supply to deliver power to all components, and use a linear regulator to step the voltage down to 5V for the active circuit components, and 3.3V for the MCU.

Tolerance Analysis:

It is important that we provide a component that prevents the scaling down of our video signal, via unwarranted voltage division, after any amplification stages. We will use a voltage buffer to protect our signal from this. It will provide a large input impedance with a very small output impedance, driving the voltage division equation between output buffer impedance and input impedance to the next module close to 1, leaving the signal unaltered. This will help maintain expected brightness and saturation levels as the signal propagates through the circuit. The visuals below show the composite video signal post-amplification with and without a buffer stage. The traces below will compare the signal at 'Vin' (leftmost node on Figure 1) with the signal at 'Vout' (rightmost node on Figure 1). The y-axis increments of each trace graph are identical.

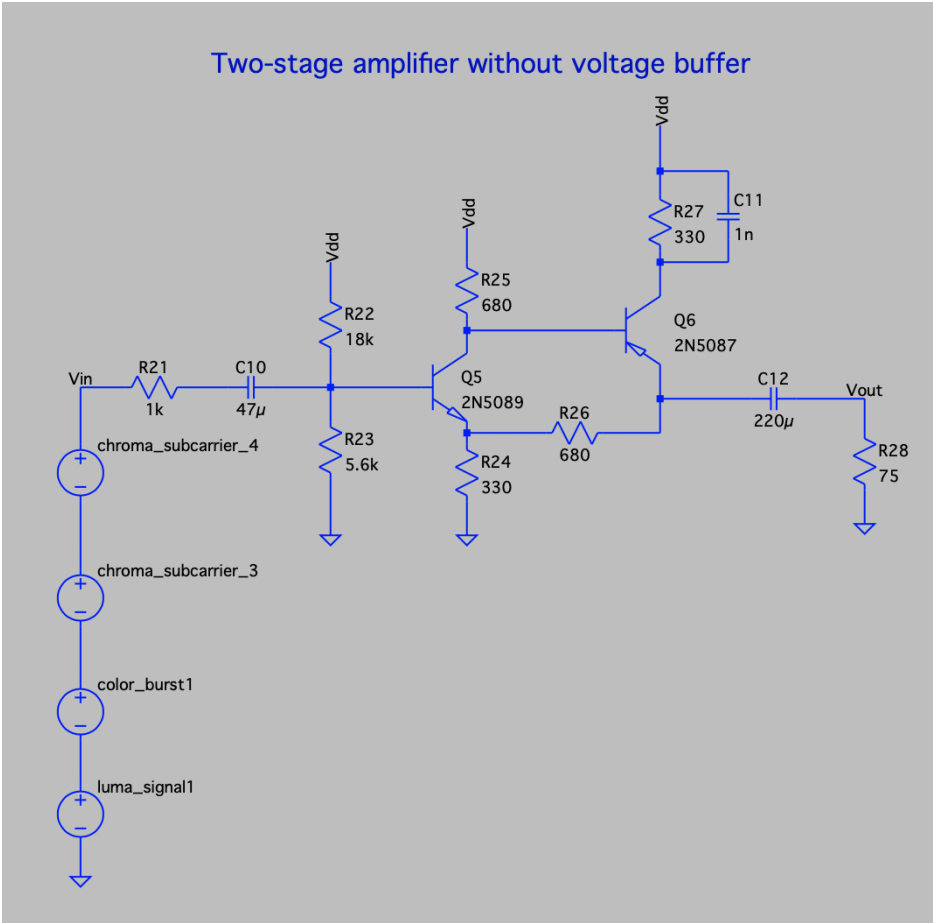

Figure 1: Amplification circuit without a voltage buffer

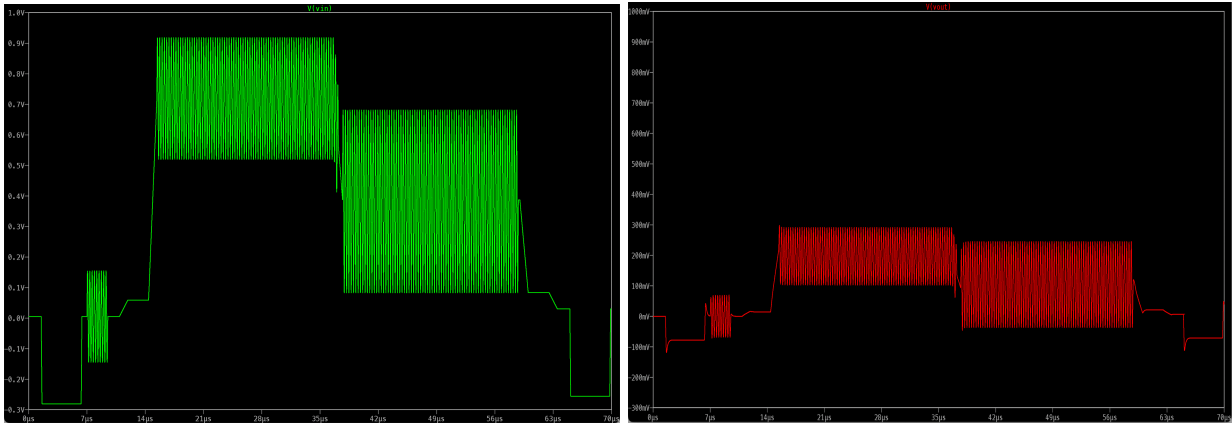

Figure 2: Input (left) compared with output (right) of Figure 1 circuit. Notice how the signal was scaled down.

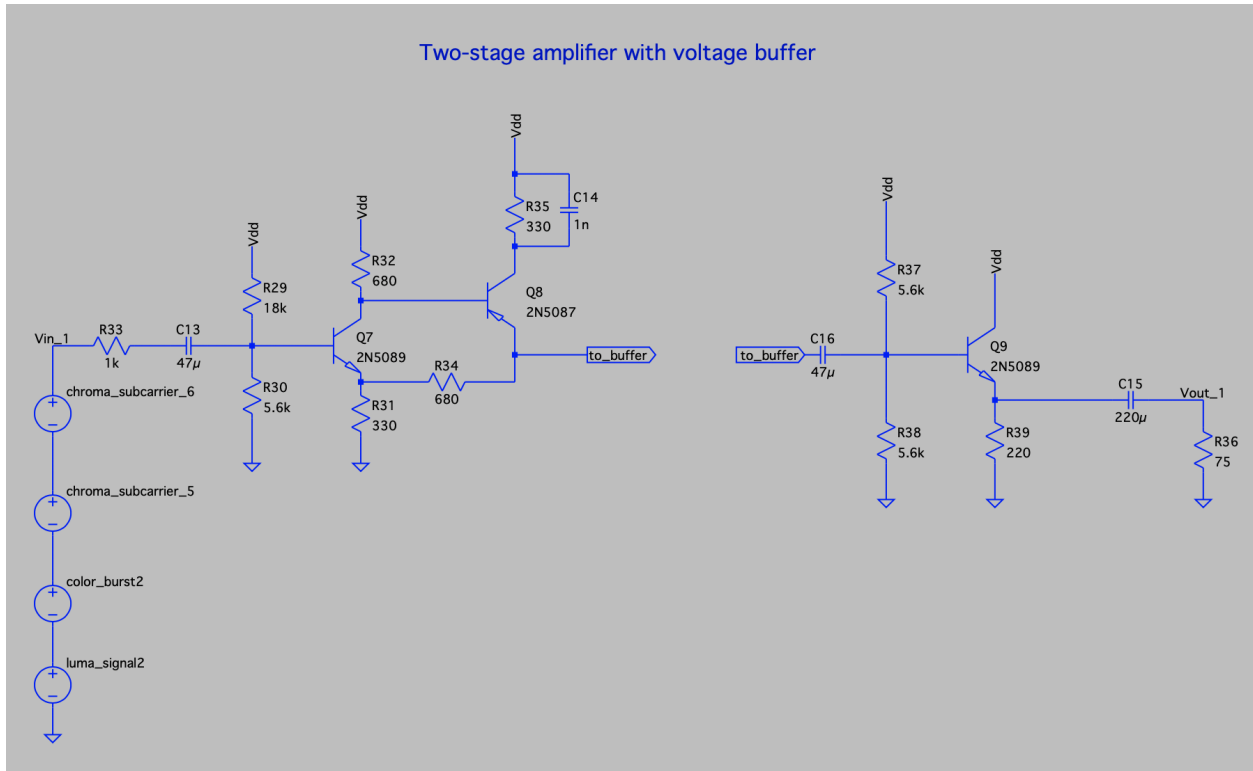

Figure 3: Amplification circuit with a voltage buffer

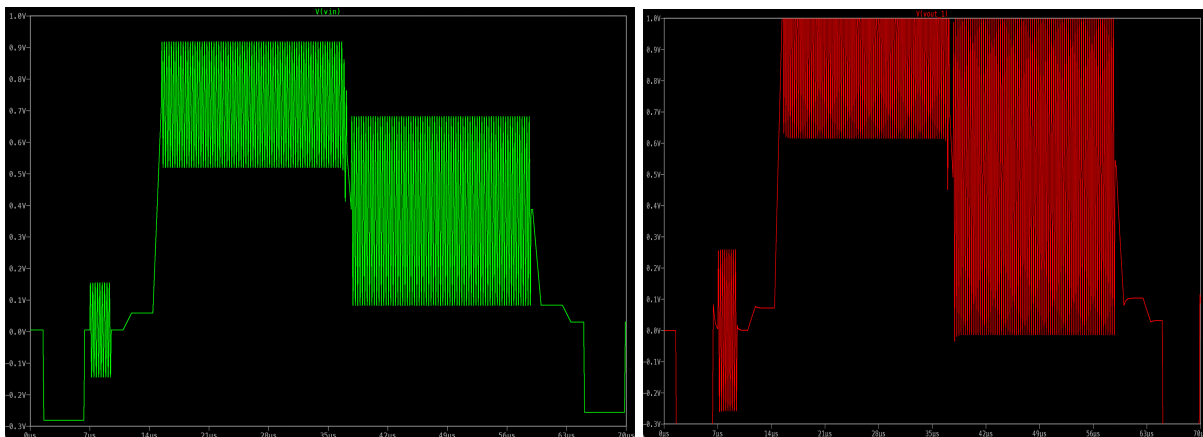

Figure 4: Input (left) compared with output (right) of Figure 1 circuit. Notice how the signal was properly amplified and scaled up with the presence of the voltage buffer. The output signal reaches a maximum value of 1.4 volts, but is clipped in order to maintain equal voltage increments across all trace graphs.

Ethics and Safety

In accordance with the IEEE Code of Ethics, we will disclose all personal knowledge gaps and uncertainties with the team in order to fully understand all issues collectively during the development process. Likewise, we will only undertake tasks with a sufficient knowledge basis, ensuring team safety with testing with lab instrumentation (e.g. power supply) (IEEE 2020, IEEE Code of Ethics, Section 6). We will take measures to ensure the width of the copper etchings on our PCB (especially copper traces connected to power sources) are wide enough to prevent excessive heat and thereby potential damages, as in accordance with the IPC 2221 standard (IPC International 2003, IPC-2221A: Generic Standard on Printed Board Design, Section 6.2). In addition, in regulating voltages and currents throughout our device, we will abide by OSHA 1910.303(b)(5), preventing faults correctly with all electrical components. For example, we will provide voltage buffering when necessary between modules to lower input current. This will also be achieved with current dividers when appropriate (OSHA 2008, 1910.303 - General, Section b5).