



Single-Phase Power Quality Analyzer

I ILLINOIS

ECE 445
Senior Design Laboratory

By Isaac Herink, Jeffrey Pohlman, Joseph Kim

Project No. 72

Introduction

- Microcontroller based power quality analyzer
- Able to measure RMS voltage and current, real and apparent power, and power factor
- Real time data reporting via a screen on top of the enclosure
- Portable, isolated enclosure that protects user from high voltage



Problem

- Commercial analyzers are expensive
- Complex to use and require training or manuals
- Stationary and heavy
- Includes a lot of features most users may not utilize



Yokogawa WT1800 High Performance Power Analyzer (\$10,000+)



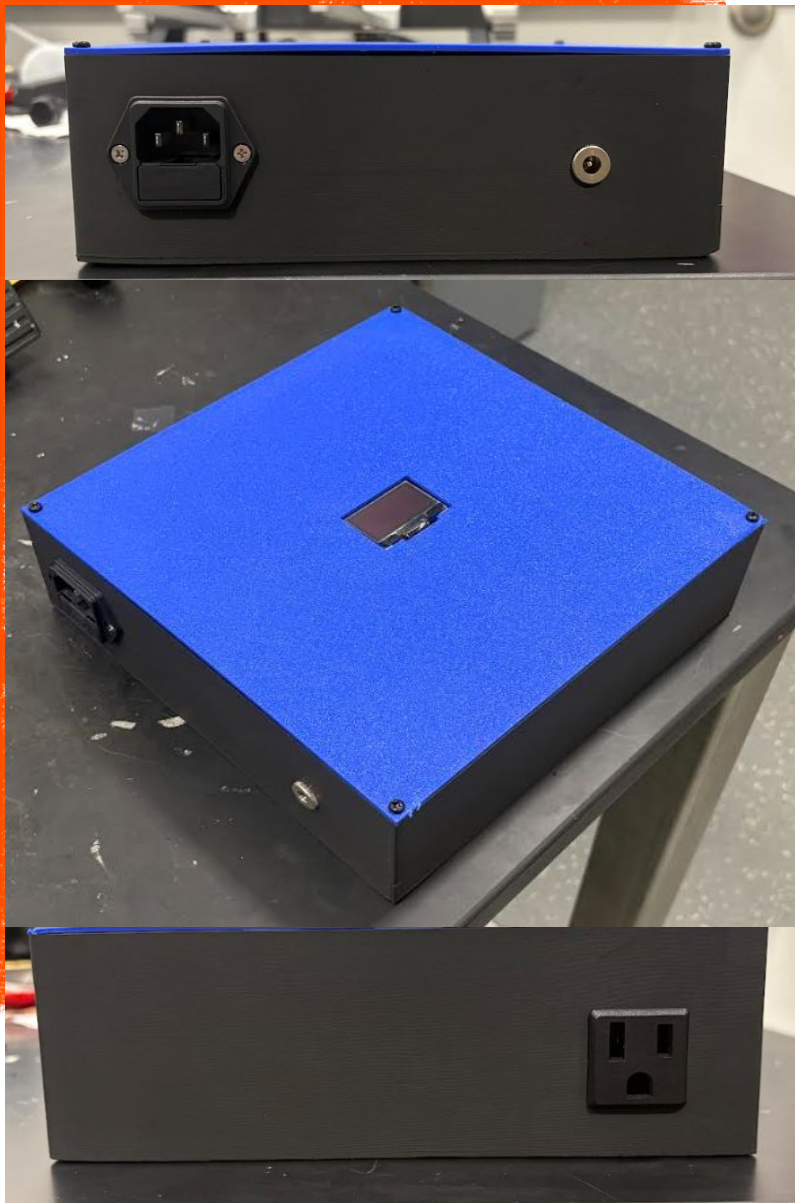

Solution

- Budget friendly (under \$200)
- Simple interface
- Live data reporting
- Portable, lightweight
- Rated for most low level applications

Overview



1

Requirements

- High Level Requirements

2

System

- Block Diagram

3

Design

- Board Power
- Signal Conditioning
- High Voltage and Enclosure
- Embedded Processing

4

Results

- Test Results

5

Conclusion

- Challenges
- Ethics
- Future Work





Section 1

Requirements

Project No. 72



High Level Requirements

Measurement Accuracy:

- $\pm 5\%$ RMS Voltage
- $\pm 10\%$ RMS Current
- $\pm 10\%$ Real and Apparent Power
- ± 0.10 Power Factor

Time-Synchronized Sampling:

- Minimum sampling rate of 3 kHz

Real Time Reporting:

- Compute/transmit at 5 Hz
- Update in real time



Section 2

System Overview

Project No. 72

Block Diagram

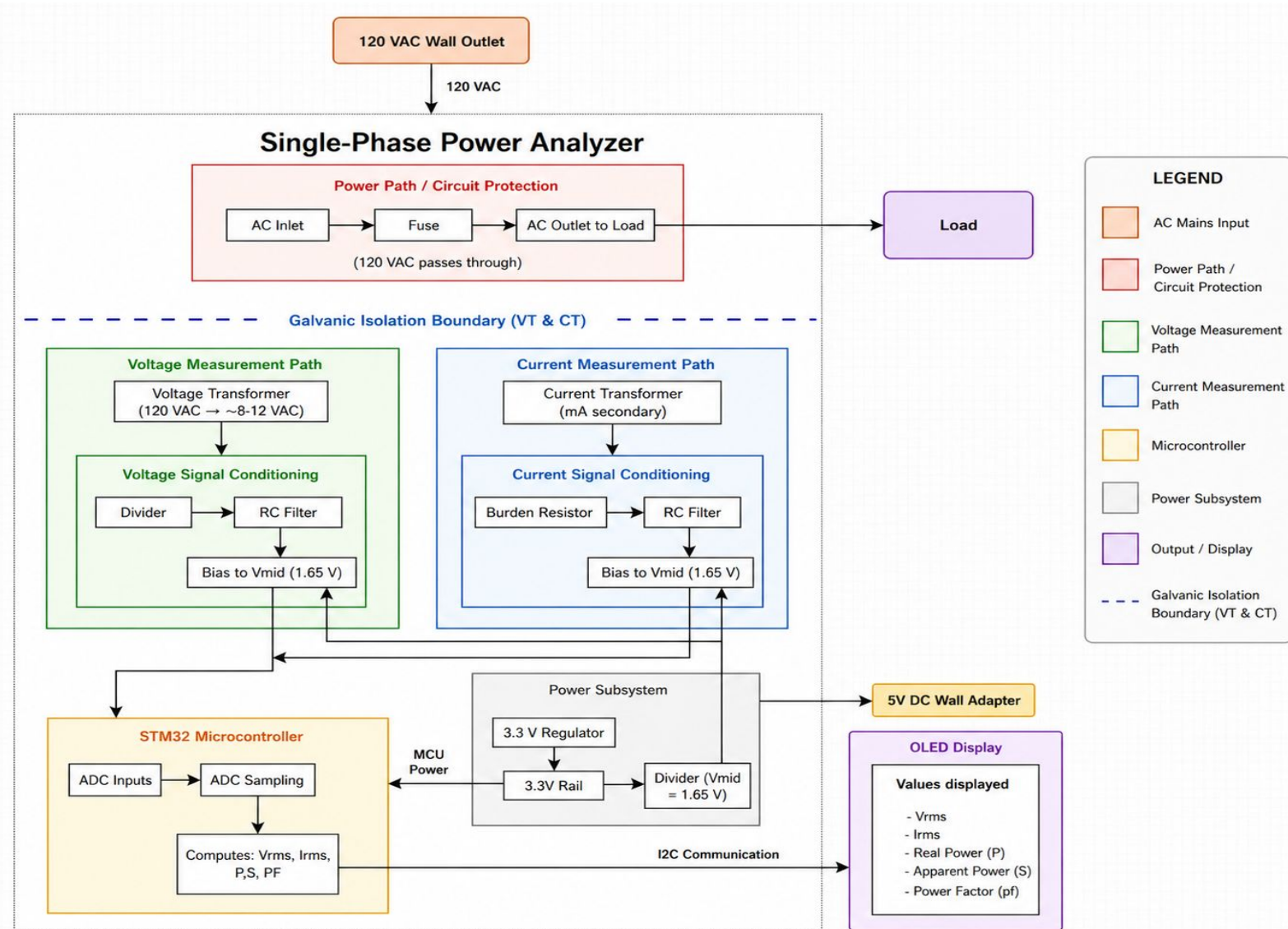



Section 3

Design

Project No. 72



Board Power

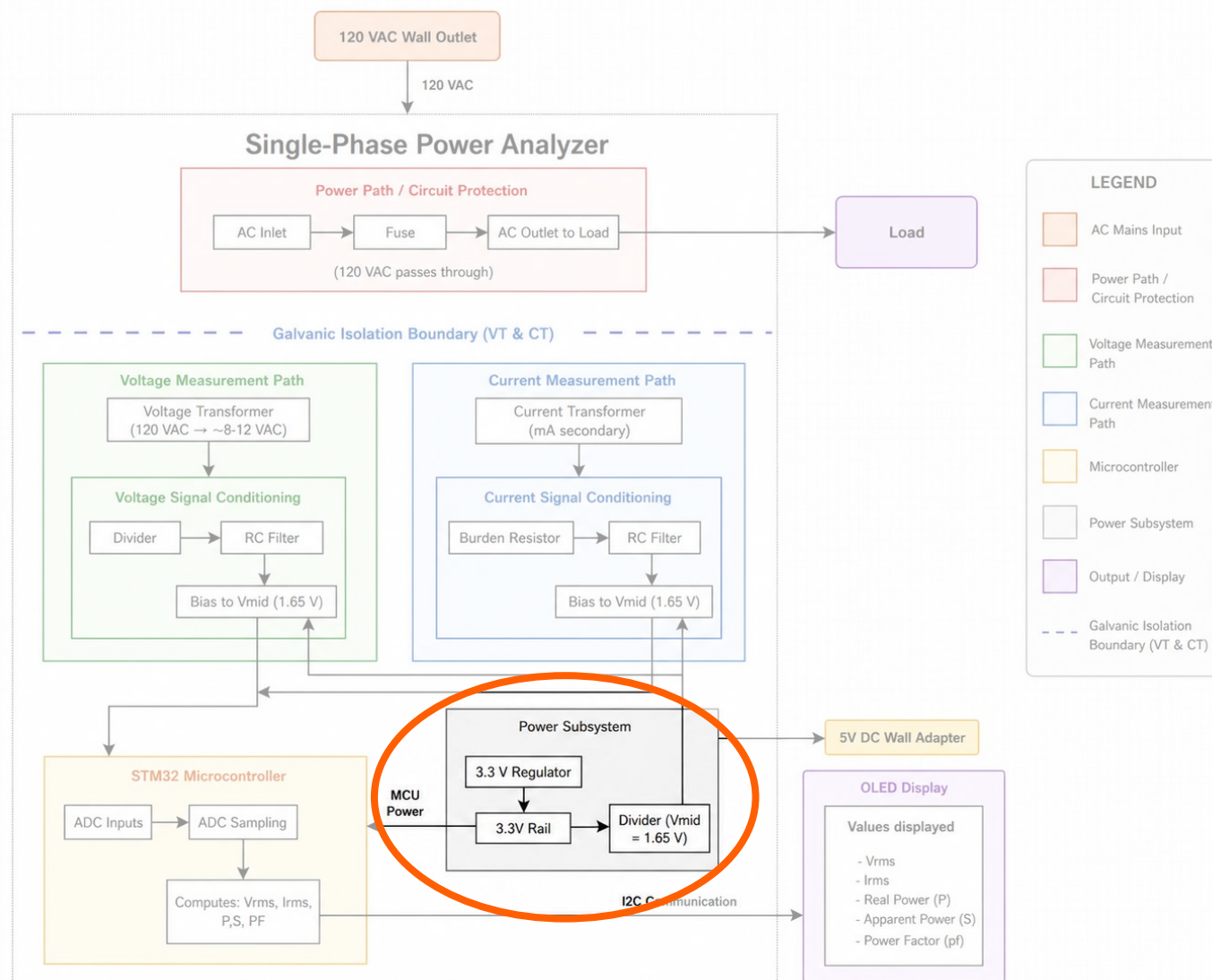

Board Power

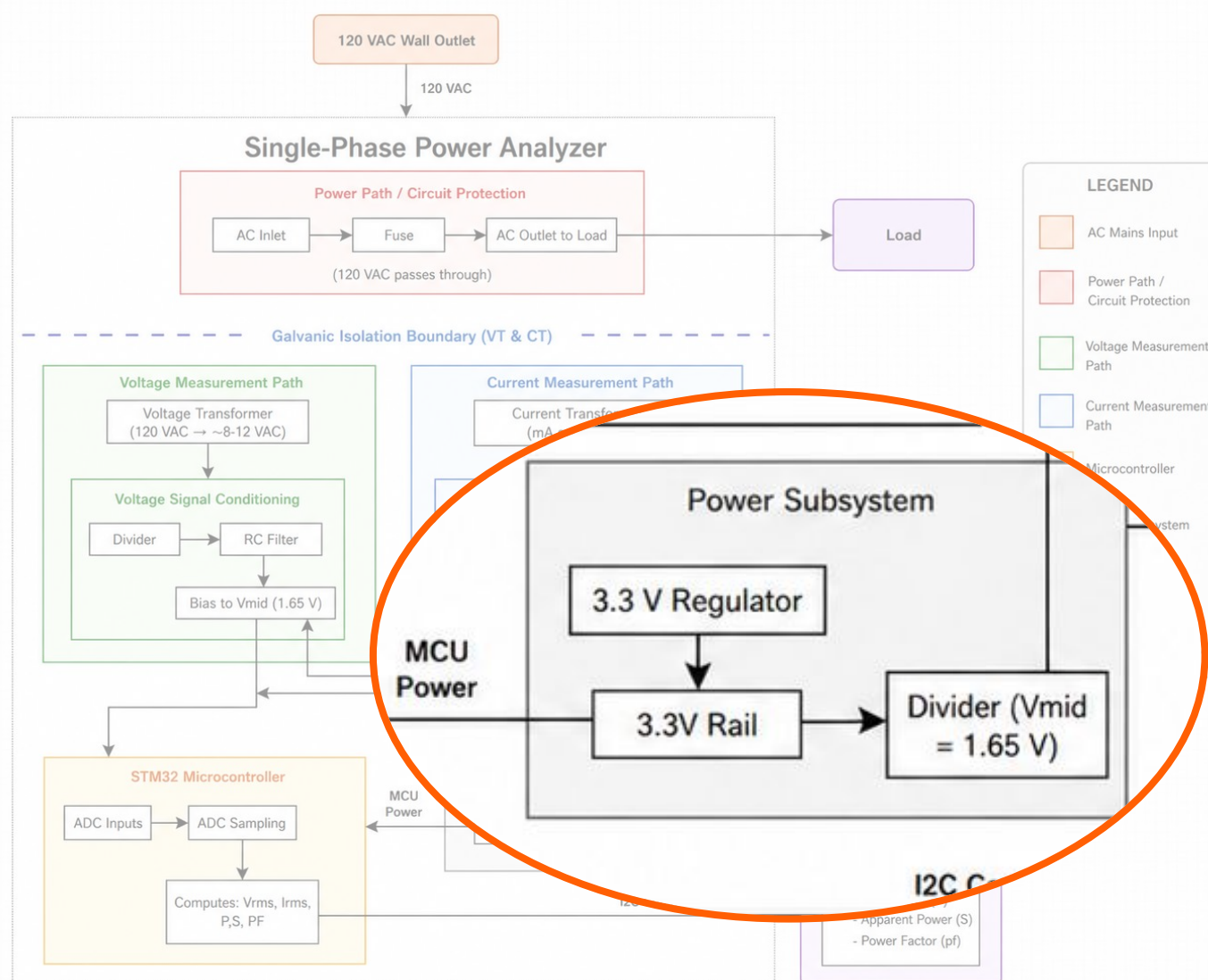

Board Power

Requirements

- Convert 5 volts to 3.3 volts
- Provide stable/consistent voltage
- No fluctuations or voltage drop

Design

- Terminal block receives 5 volts from wall adapter
- Fuse and diode
- Bulk and decoupling capacitor
- 3.3 volt regulator

Verification

- Soldered on first
- DC power supply to simulate 5 V and oscilloscope to measure 3.3 V

5 V wall adapter

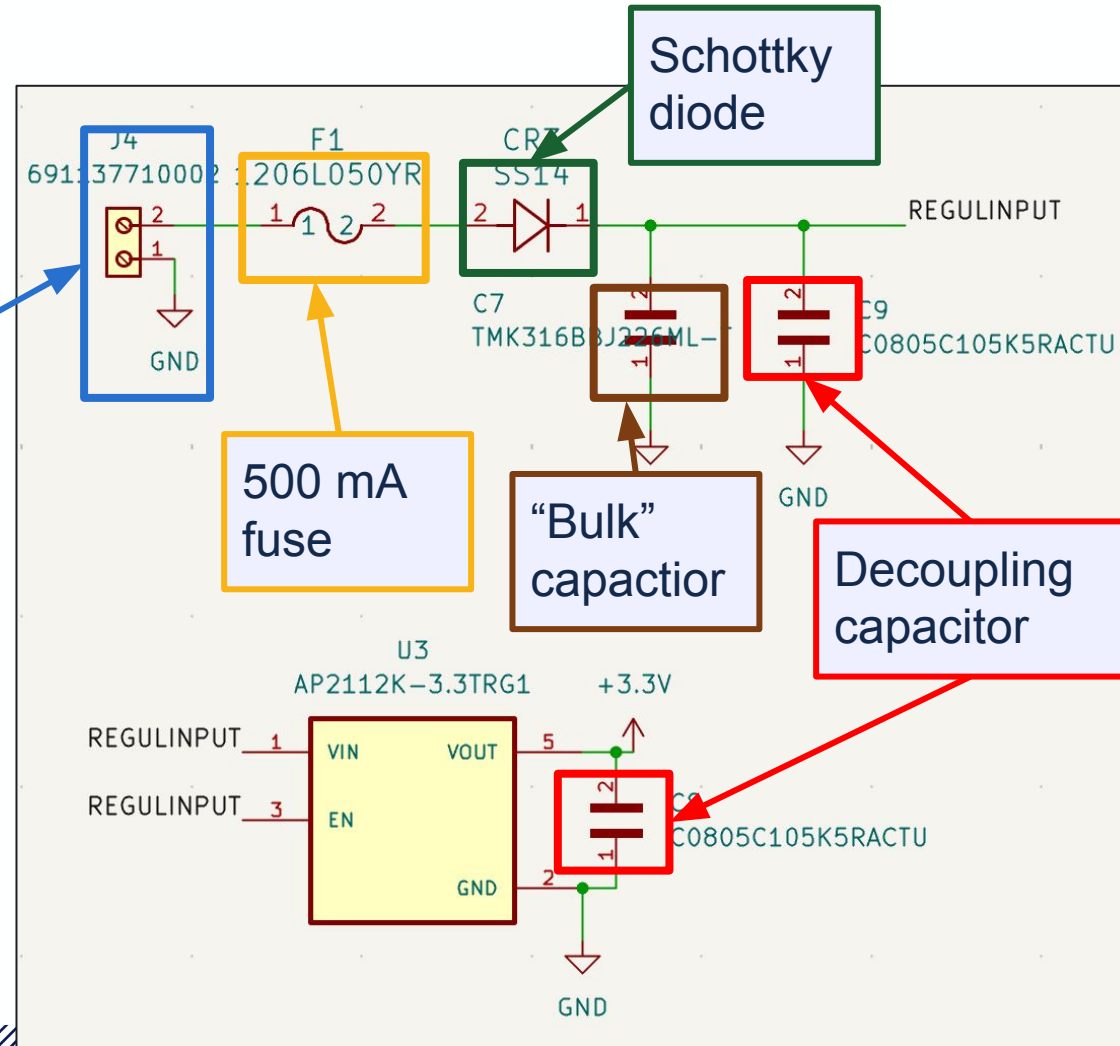

Signal Conditioning/Sensing

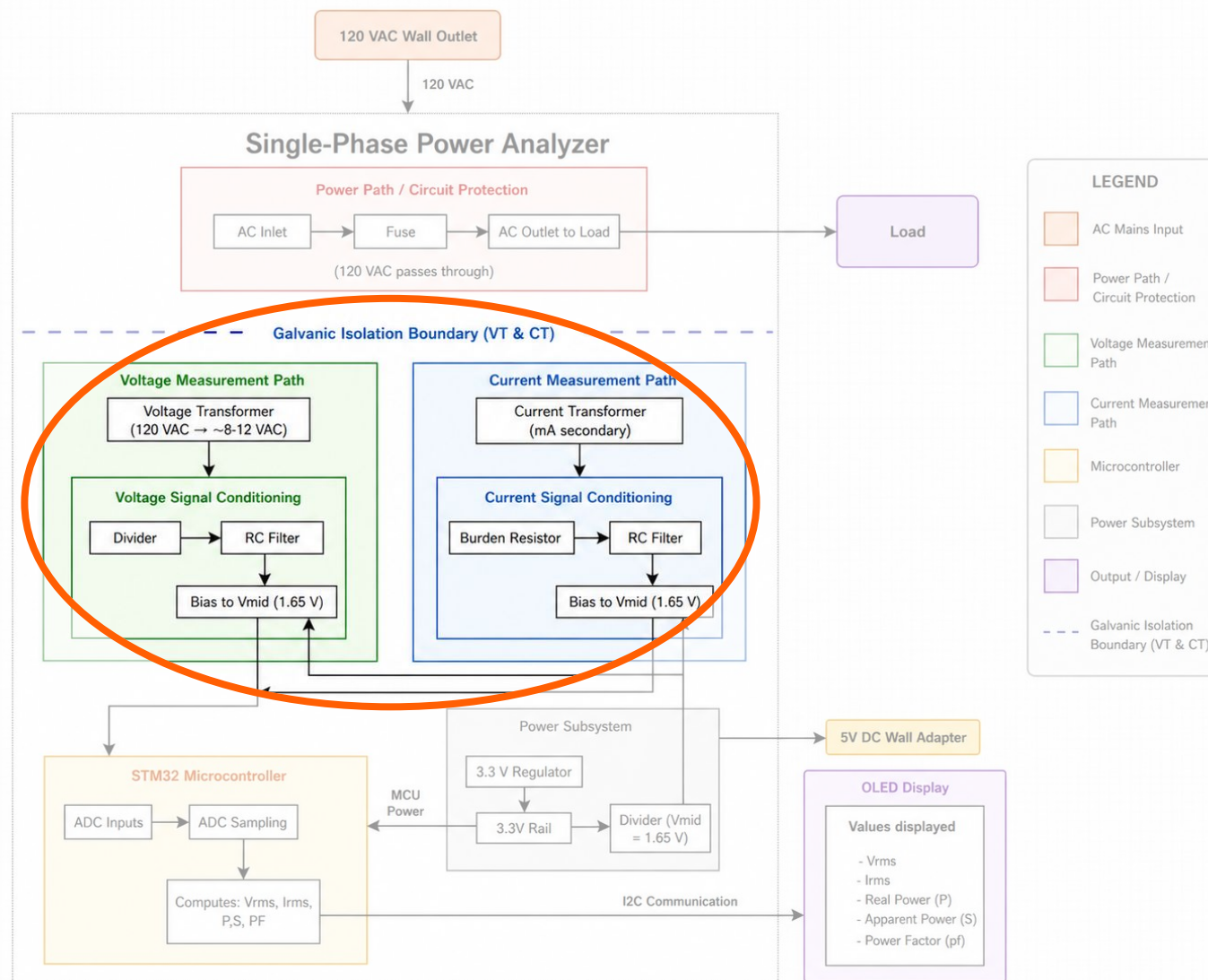

Signal Conditioning/Sensing

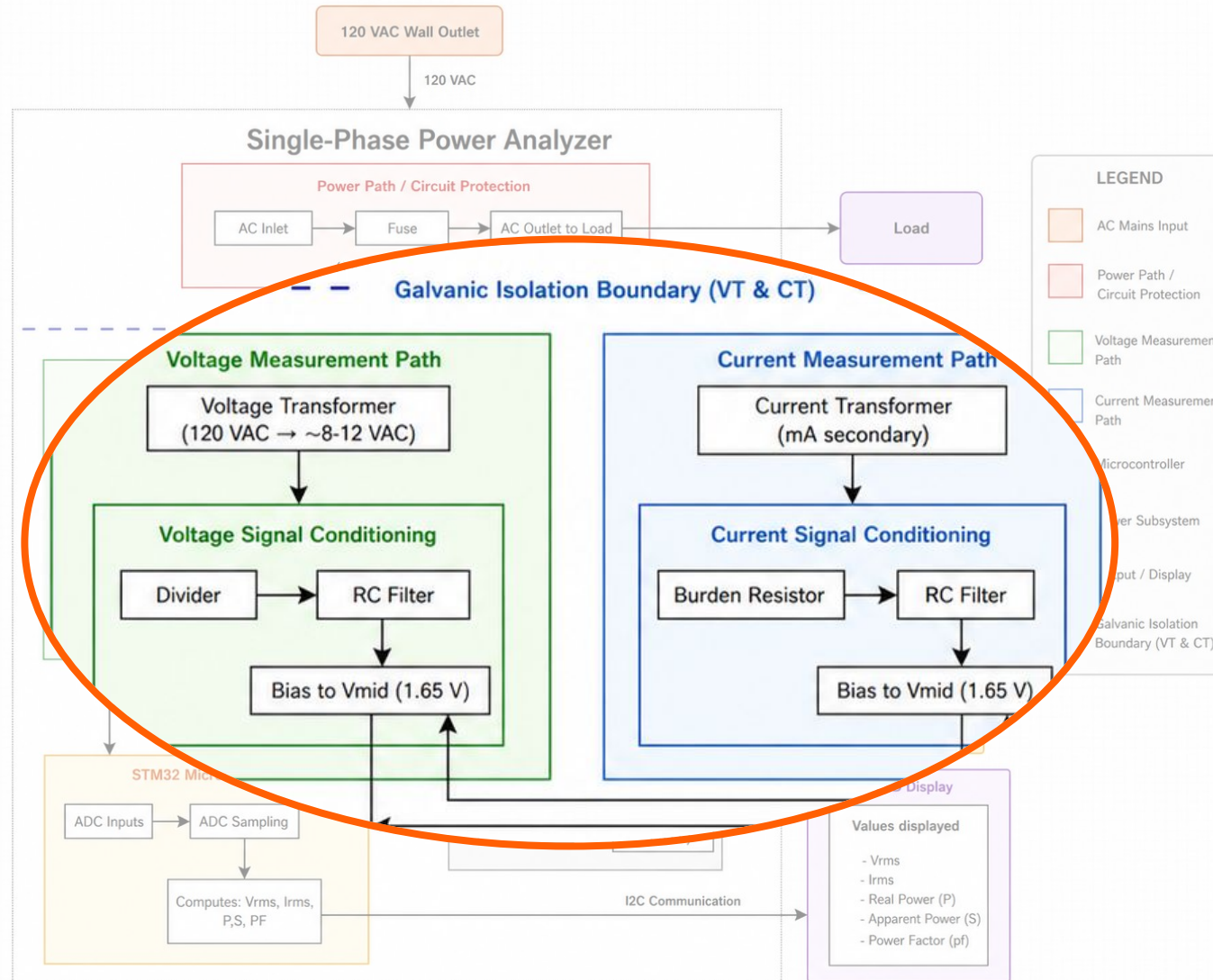

Signal Conditioning/Sensing

Requirements

- Center signal at 1.65V
- Range within 0-3.3V
- Uniform phase shift between voltage and current

Design

- Voltage & Current Transformers
- Burden resistor
- Voltage divider
- AC coupling
- DC bias
- RC filter
- Protective diodes

Verification

- VT/CT turn tests
- Vary input, check outputs

Section 3

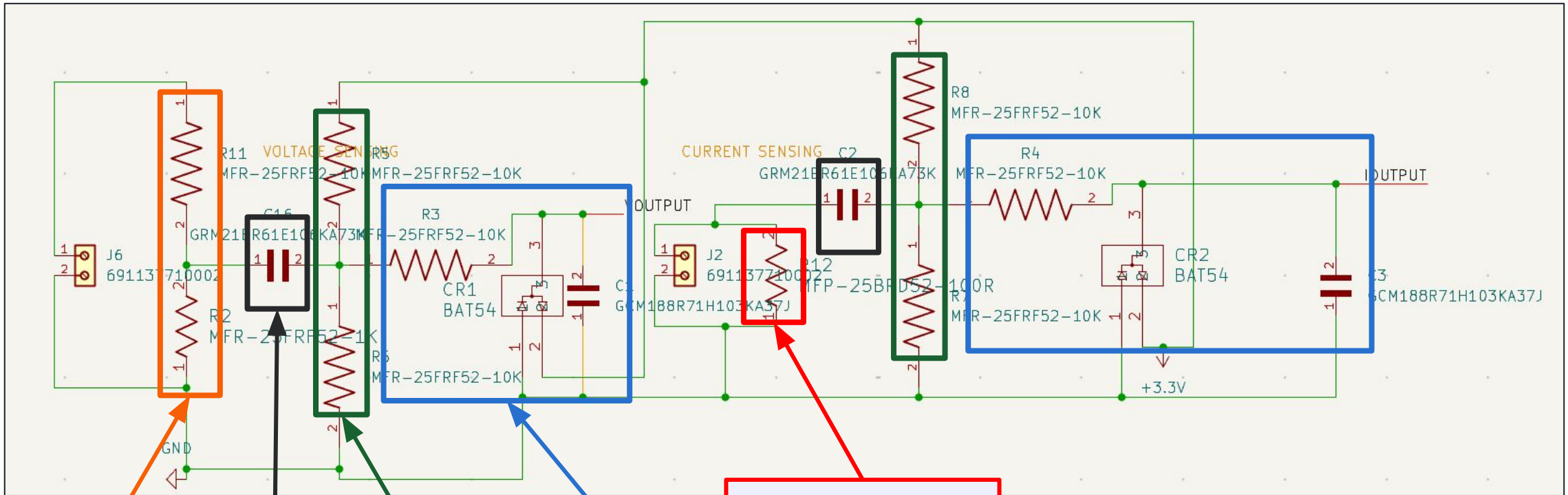

Voltage divider

DC bias

AC coupling

RC filter/ Protective diodes

Burden resistor

Voltage Transformer

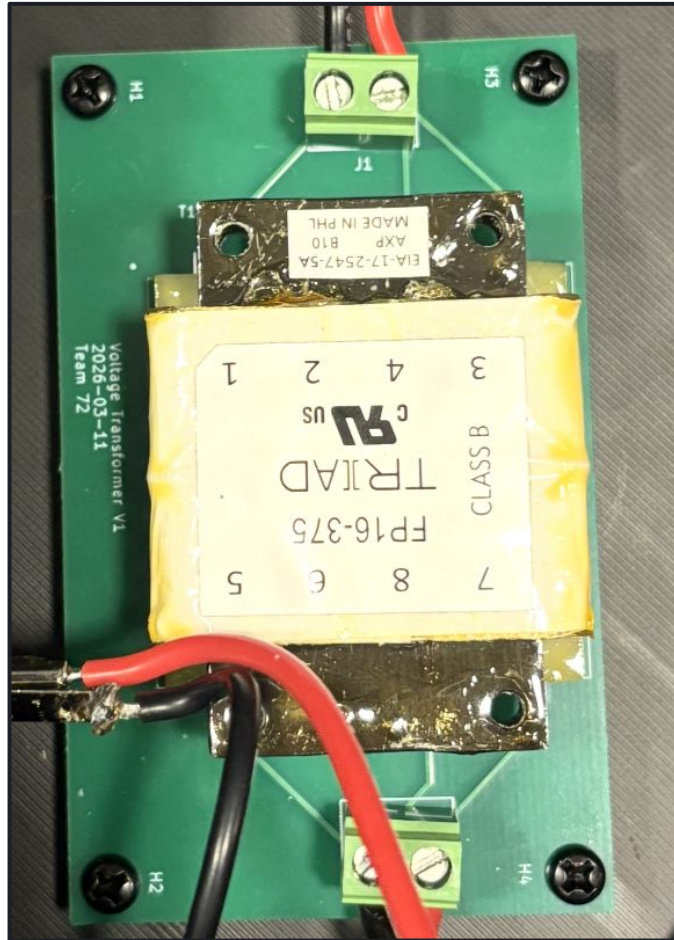

Current Transformer



Embedded Processing

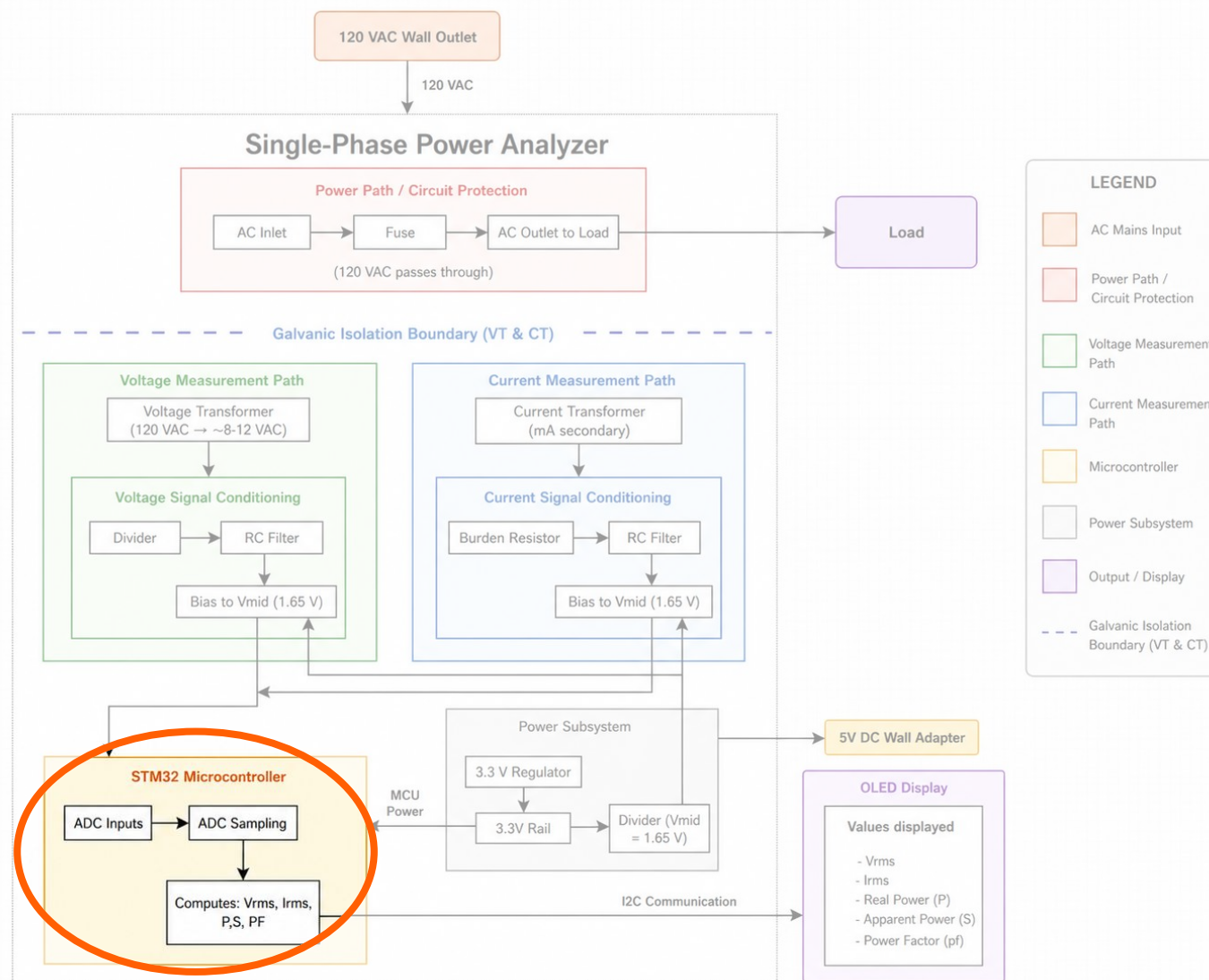

Embedded Processing

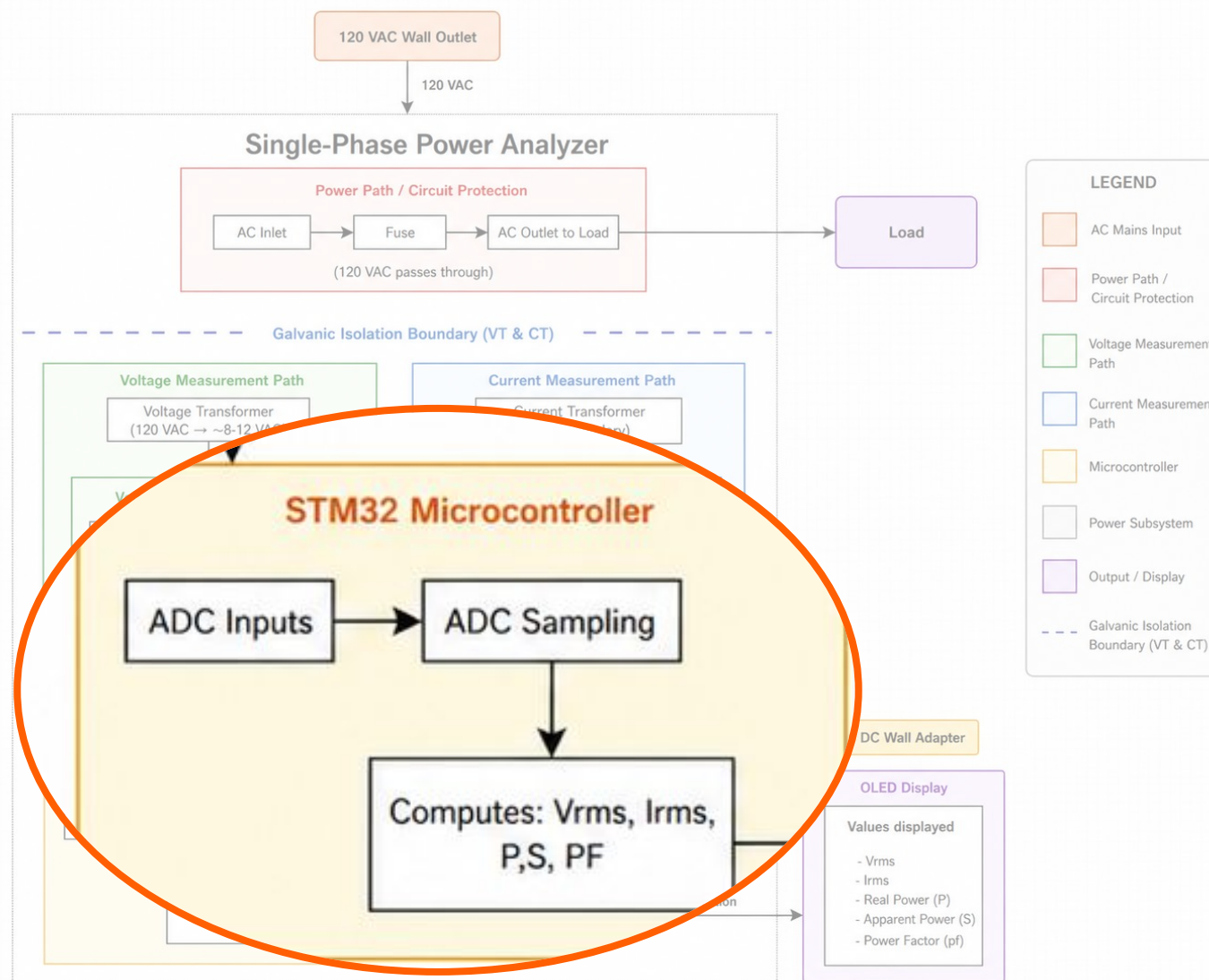

Embedded Processing: Data Acquisition

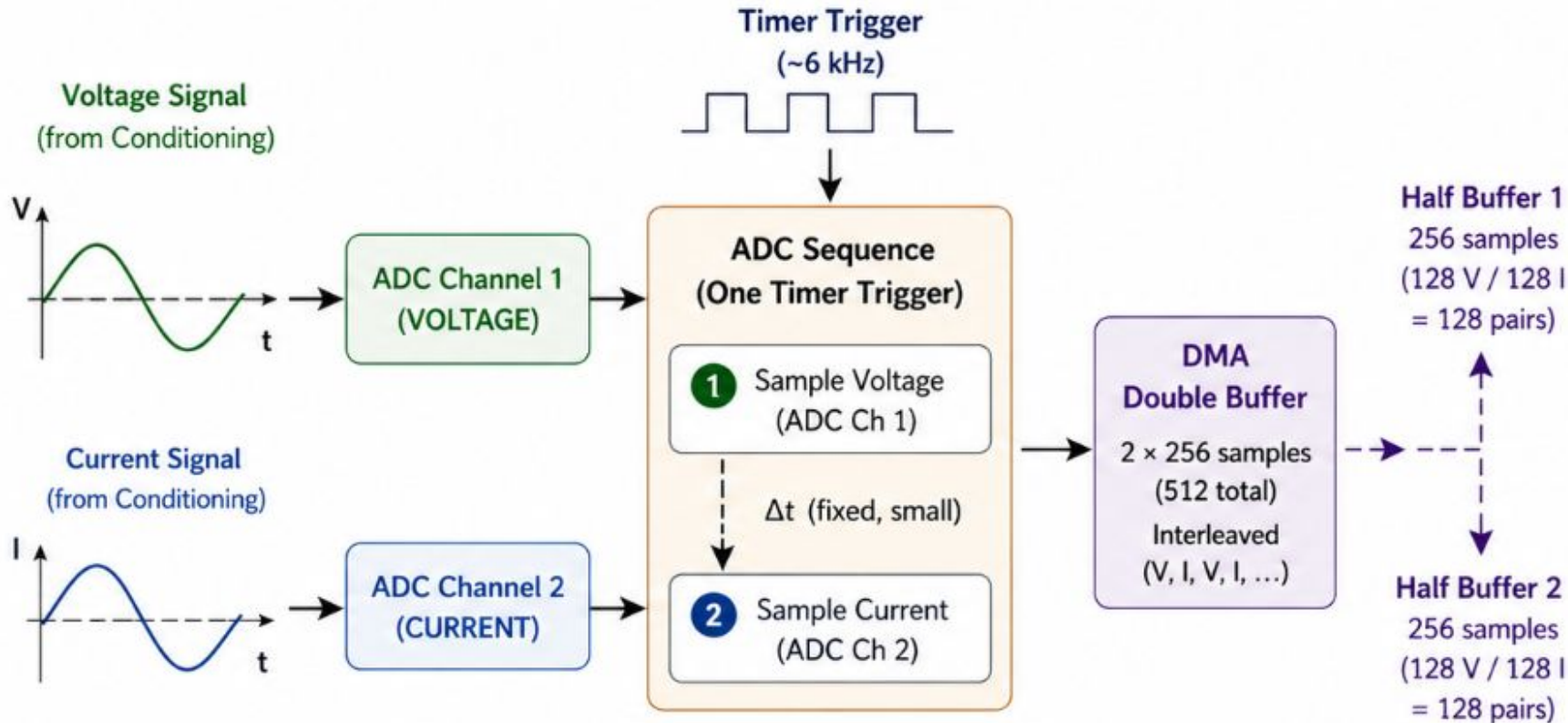

- Timer-triggered sampling (6 kHz)
- Voltage then current (sequential ADC)
- Fixed, small inter-channel delay (Δt)
- Process on half-buffer completion
- ~100 samples per 60 Hz cycle

Signal Processing Pipeline

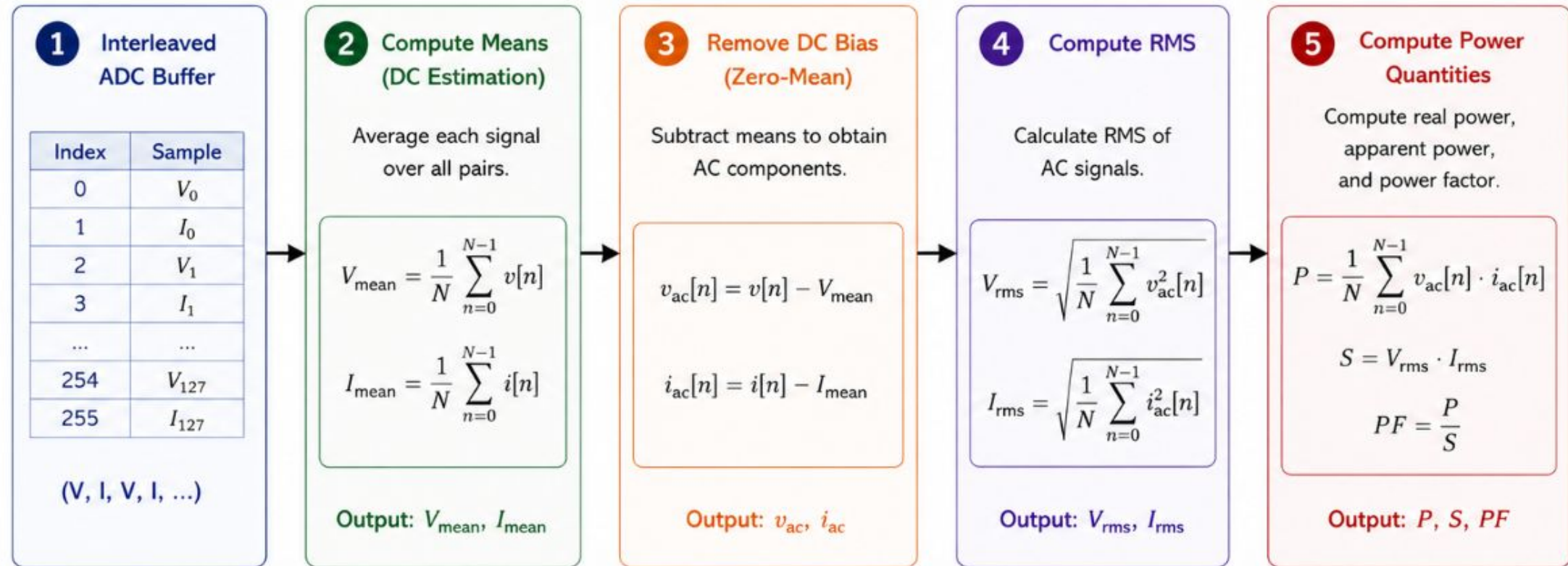

High Voltage Protection and Enclosure

Requirements

- Maintain isolation between HV and LV
- Overcurrent fault protection
- Secure connection between inlet and load
- Safe and efficient enclosure

Design

- 6.3A slow blow fuse
- Physical separation between HV and LV
- 3D printed enclosure
- Components rated for 120VAC, 5A

Verification

- Visual inspection
- Continuity and isolation testing
- Checking data sheets
- Check connection integrity

Enclosure Design

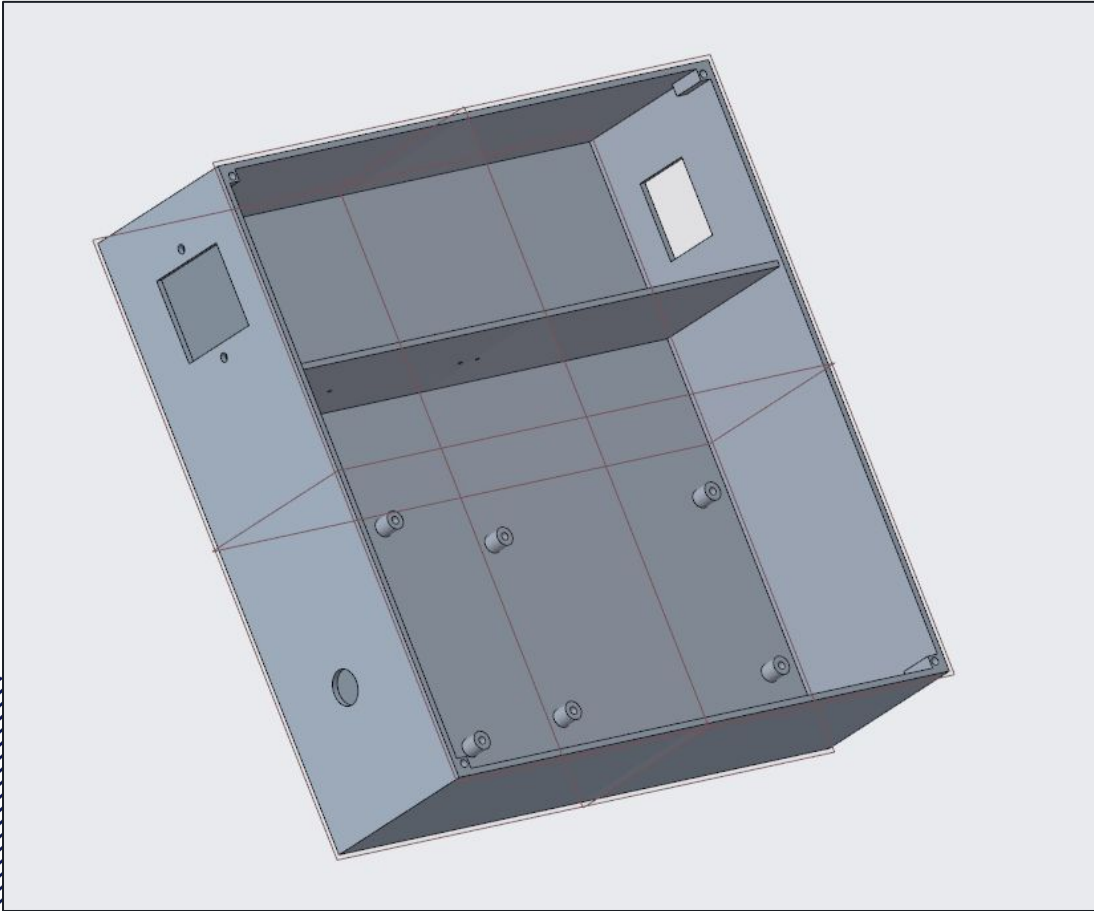

Project No. 72

Inlet/Outlet





Section 4

Results

Project No. 72



Test Results: 40W Incandescent Bulb



Measurement	WT310 E	PQA	Error	Ideal Error
VRMS [V]	118.49	118.61	0.101%	$\pm 5\%$
IRMS [A]	0.326	0.328	0.613%	$\pm 10\%$
P [W]	38.70	39.79	2.817%	$\pm 10\%$
S [VA]	38.70	40.24	3.979%	$\pm 10\%$
PF	1.00	0.989	0.011	± 0.10

Test Results: Soldering Fan



Measurement	WT310 E	PQA	Error	Ideal Error
VRMS [V]	118.34	117.95	0.330%	± 5%
IRMS [A]	0.233	0.231	0.858%	± 10%
P [W]	17.59	19.16	8.926%	± 10%
S [VA]	27.61	28.57	3.477%	± 10%
PF	0.637	0.674	0.037	± 0.10

Test Results: Laptop + Charger



Measurement	WT310 E	PQA	Error	Ideal Error
VRMS [V]	118.74	119.17	0.362%	$\pm 5\%$
IRMS [A]	0.662	0.666	0.604%	$\pm 10\%$
P [W]	46.48	45.12	2.926%	$\pm 10\%$
S [VA]	78.64	80.78	2.721%	$\pm 10\%$
PF	0.591	0.558	0.033	± 0.10



Section 5

Conclusion



Project No. 72



Challenges

Topic	Challenge	Solution
Voltage Transformer PCB	PCB was designed incorrectly	Increased resistor value of the VD
Board Power System	Suggested design change	5V wall adapter
Real Time Reporting	Noticed that a refresh rate of 3 Hz	Decouple display from sample processing

Considerations

What we've learned:

- PCB development
- Analog signal conditioning design
- Real-time embedded processing
- Engineering mindset

What we'd change:

- Enclosure
- Display
- VT PCB
- Firmware optimization (update rate)

Ethics

“Hold paramount the safety, health, and welfare of the public”

- Separate high and low voltage (different PCBs)
- Enclosure keeps electrical components out of reach
- Overcurrent fault protection

Future Work

- kWh usage tracking
- Power factor correction
- Custom graphical user interface to display information neatly and uniquely
- Bigger screen with touchscreen capabilities

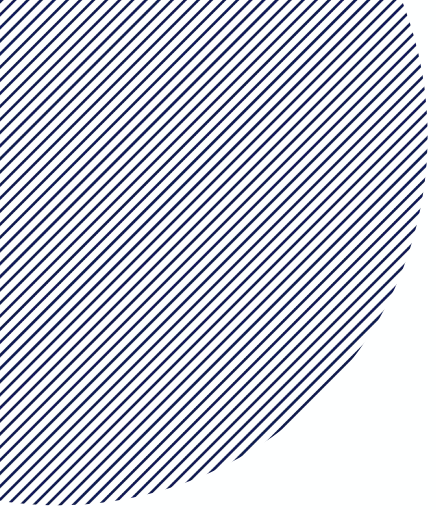

Questions?



THANK YOU!

I ILLINOIS

Project No. 72