

# Ferrofluid Clock

By

Hanyao Zhang  
Zhiyuan Yao  
Ting-Wei Tsu

Final Report for ECE445, Senior Design, Fall 2016  
TA: Luke Wendt

December 7, 2016  
Project NO. 32

## **Abstract**

This report documents the building process of a ferrofluid clock over the course of the semester. To successfully finish the project, we explore the properties of electromagnetic field and electromagnets. The ferrofluid lava lamp uses electromagnets to control ceramic magnets discs, which in turn manipulates the flow of ferrofluid in a sealed plastic glass container. We start by introduce our project objectives and design overview. Next, we detail the design process and decision making along the experiments and testing. The verification for requirements of each subsystem follows afterwards. Finally, we conclude the report with the final product result and thoughts on potential future work.

# Contents

## [1. Introduction](#)

### [1.1 Modularity](#)

## [2 Design](#)

### [2.1 Physical Display](#)

#### [2.1.1 Particle Board Scaffold](#)

#### [2.1.2 Plexiglass Container](#)

#### [2.1.3 Spools and Backboard](#)

#### [2.1.4 Electromagnets](#)

### [2.2 Power Supply](#)

## [3. Design Verification](#)

### [3.1 Physical Display](#)

#### [3.1.1 Particle Board Scaffold](#)

#### [3.1.2 Plexiglass Container](#)

#### [3.1.3 Spools and Backboard](#)

#### [3.1.4 Electromagnets](#)

### [3.2 Power supply](#)

## [4. Costs](#)

### [4.1 Parts](#)

### [4.2 Labor](#)

### [4.3 Total Cost](#)

## [5. Conclusion](#)

### [5.1 Accomplishments](#)

### [5.2 Uncertainties](#)

### [5.3 Ethical considerations](#)

### [5.4 Future work](#)

## [References](#)

## [Appendix A Requirements and Verifications Table](#)

# 1. Introduction

Desktop digital clock is commonly used in home or office, but certain drawback exists for the current prevalent design. This project aims to improve the digital clock displaying mechanism and to offer viewing and entertainment value. It also offers the ability to operate in the manner similar to a lava lamp or some other passive display. This product features a sealed container tank filled with water and ferrofluid, which is in control of the electromagnets-ceramic magnet discs array assembly. A computation and control module is responsible for switching operation of the electromagnets. The display is able to show digits or other shapes in ferrofluid. In the upcoming chapters, we go into details of the physics, control and engineering principles behind the hardware and software. Figure 1 shows the general block diagram and the relation between each module.

Figure 1. System overview



## 1.1 Modularity

This project has several core components. Figure 1.1 shows the the block diagram of the modules.

Figure 2. Detailed system block diagram

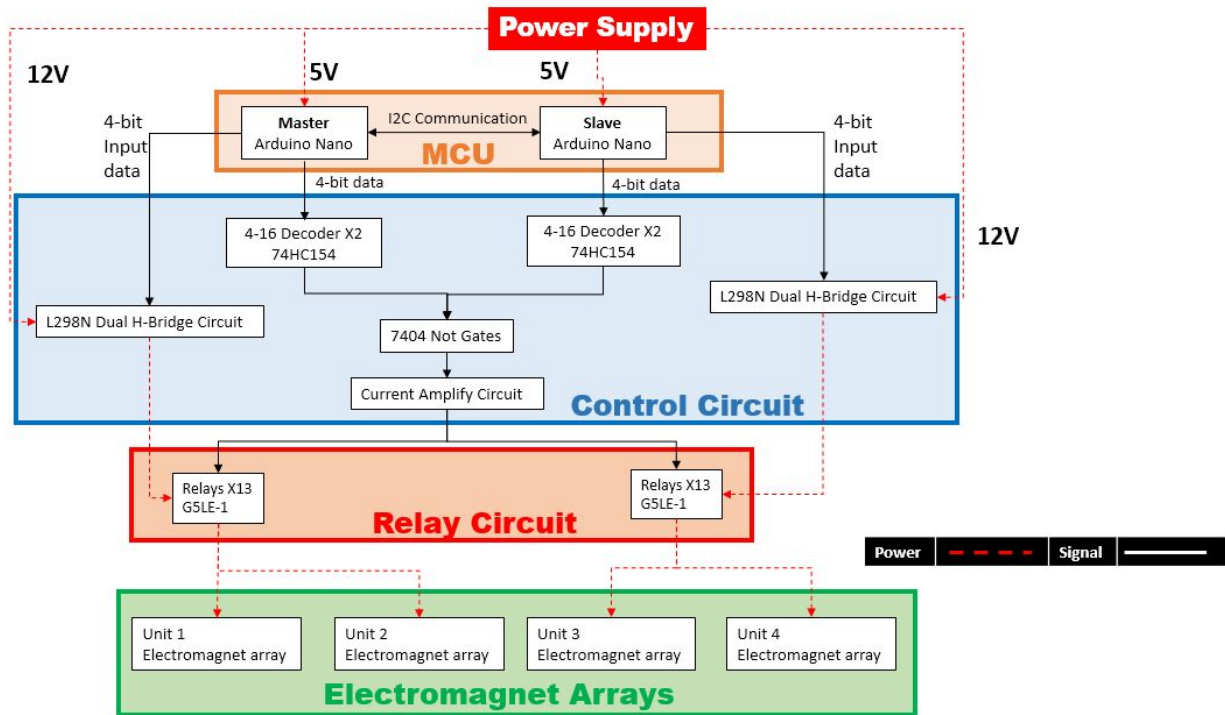

**Power supply unit:** The compute circuit needs to operate at 5.0 V and the electromagnets array needs to operate at 12.0 V and 2.0 A current. To ensure the desired operation of each module, we designed a power supply unit that uses a transformer rated at 95 VA and 5A to convert the 110 V AC into 18.0 V DC and regulates the voltage to 12.0 V and 5V respectively.

**Computation unit:** This part of the project is responsible for code and decode the control signal being sent to the control unit. It is composed of two Arduino Nano, each serving half of the electromagnet array.

**Control unit:** This unit directly control the current direction going through the electromagnets.

**Electromagnet arrays:** Hand-wound electromagnets make up four counts of figure 8.

**Ceramic magnet disc array:** ceramic disc put in the tubes in the wood scaffold. These magnet discs are directly controlled by the electromagnets. The ceramic magnet discs can move freely in the tube.

**Water tank display:** This water tank is divided into four parts, each for a single electromagnet array. The tank is filled with alcohol and oil-based ferrofluid.

## 2 Design

### 2.1 Physical Display

The physical display of the design was, essentially, the front-end of our project. It was here that any activity would be witnessed. Design decisions were made with this, and durability, in mind.

#### 2.1.1 Particle Board Scaffold

The particle board was designed to be as simple to machine as possible, while achieving the resolution we wanted. We originally wanted to create separate tubes for all the magnets, but quickly realized we could achieve the same effect by drilling holes into a single board.

Particle board was chosen as the material in the interest of durability. Distance between the holes in the board, meanwhile, was almost entirely arbitrary. This fact was later exacerbated when we switched from using neodymium magnets to ceramic ones.

#### 2.1.2 Plexiglass Container

The plexiglass container was designed to be durable, leak-proof, and see-through. By using plexiglass, we were able to easily achieve the first and last of those requirements. As for leak-proofing the containers, this was done with a tightened lid (which, incidentally, was the source of the damage the containers later sustained - it became *too* tight). The plexiglass container was also separated into 4 separate chambers so that each individual array would be guaranteed the same amount of ferrofluid, regardless of the angle at which the display was set.

#### 2.1.3 Spools and Backboard

The backboard was designed with durability in mind. Its dimensions were made simply so that they would coincide with those of the container and scaffold before it. The spools, meanwhile, were designed with flexibility in mind. When we placed our order with the machine shop, we had no idea how many loops we would need on our electromagnets, so we elected to make them 4 cm long, which we believed would give us a sufficient amount of wiggle room in our final design. We used a spool design to make it easier to wind the spools; the size of the discs was made so that the electromagnets could fit into the tubes in the scaffold, in case the tubes were too long.

#### 2.1.4 Electromagnets

The design of the electromagnets was one of the few processes in our building of the project that had multiple iterations. Due to the sheer number of spools we had available, we were able to try out a number of different wire gauges, loop counts, and wiring methodologies. For example, we initially used 26 gauge wire in 200 loops around our magnets. When this was found to be grossly insufficient, we continuously upped our loop count until we were able to attract and repel the permanent magnets as needed. It was also at this point that we used a “drumstick” design, where the loops became more and more dense on one end of the electromagnet spool. Finally, after the completion of the circuit and a new constraint was introduced (needed to be at least 3 ohms), we tested more iterations, ultimately changing to 28 gauge wire and ending at a loop count of about 800 rounds per magnet.

## 2.2 Power Supply

We designed and built the power supply to offer power to the control module and the electromagnet array. The two Arduino Nano in the control module need 5 V to operate and a single electromagnet needs 12 V to be able to pull or push the ceramic magnet disc. Thus, we designed the power supply to have two ports outputting 5 V with 1.5 A at maximum each and two ports outputting 12V with 2 A at maximum. We will delve into details of the design process and decision making in the next few paragraphs.

Because the whole project is to build a ferrofluid clock for desktop use, we decided to use AC power as the source and convert AC to DC in order to power the components in the build for the ability to operate for a long period of time and a more stable power supply than using packed batteries. Figure 3 shows the overall design of the power supply circuit.

Figure 3. Overview of power supply design

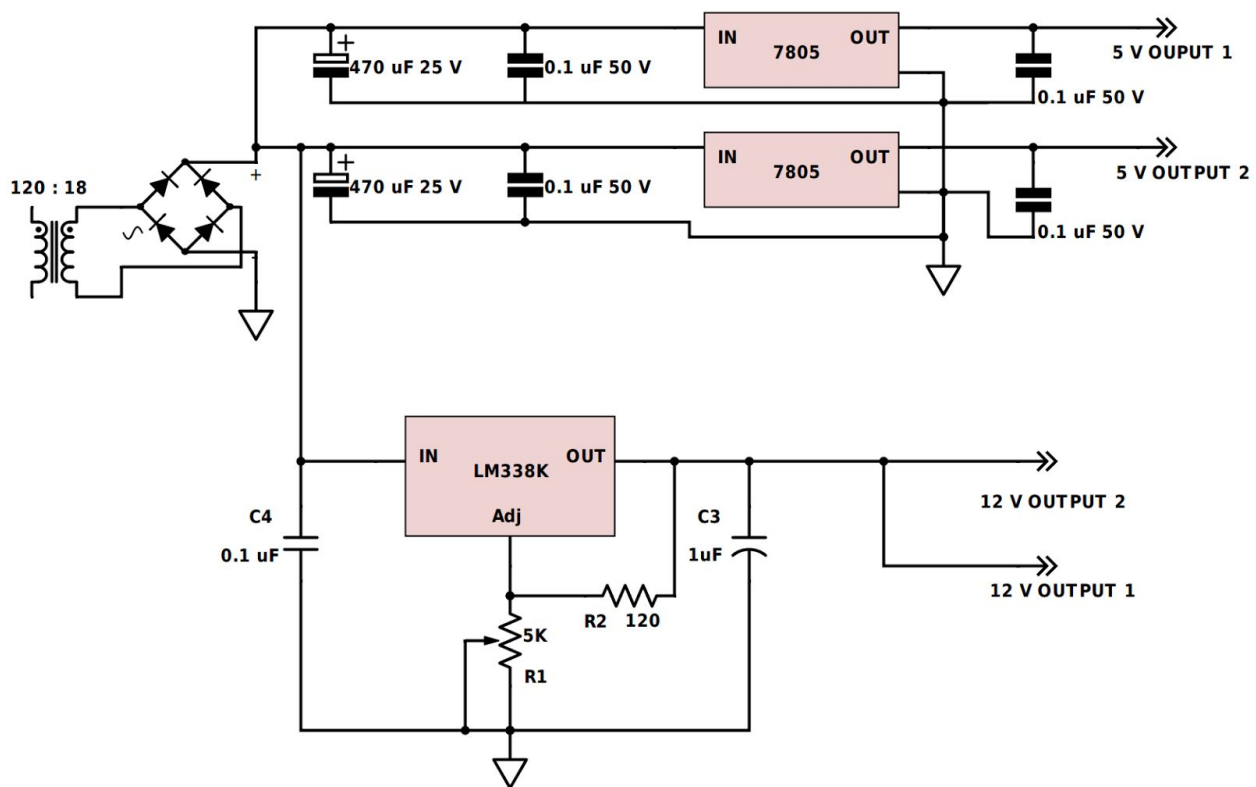

The very first component from the wall power plug is the transformer with a diode rectifier bridge. Since the Arduino Nano in the control module and the electromagnets in the electromagnet array needs DC voltage to operate, the rectifier bridge following an AC transformer that converts 120 V AC to 18V AC offers 18V DC output to the rest of the circuit. The 18V DC coming out of the rectifier bridge is regulated through two types of voltage regulator integrated circuits and we will go through the integrated circuit that regulates the

voltage to 5 V first. We used a MC7805 integrated circuit as the voltage regulator because, first it is available in the parts shop along with the require heat sink, and second, it has small volume which in turn saves the space on the circuit board. The MC7805 integrated circuit has the maximum rated current of 1.5 A, which is more than enough for powering up an Arduino Nano. Figure 4 shows the detailed circuit diagram for the two 5V regulation circuit and figure 5 shows the illustration of MC7805 integrated circuit. In addition, we connected capacitors in parallel with the MC7805 to soothing the voltage wave. To limit the temperature of the MC7805 under its maximum operating temperature, we installed heatsink on it, as illustrated by Figure 6.

Figure 4. Detailed circuit diagram of 5 V power supply

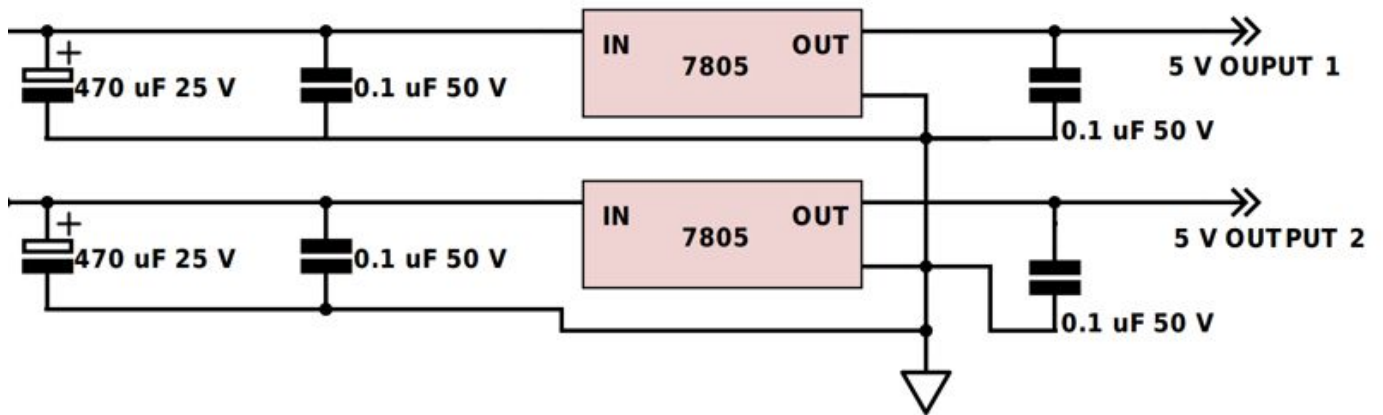

Figure 5. Illustration of MC7805 integrated circuit



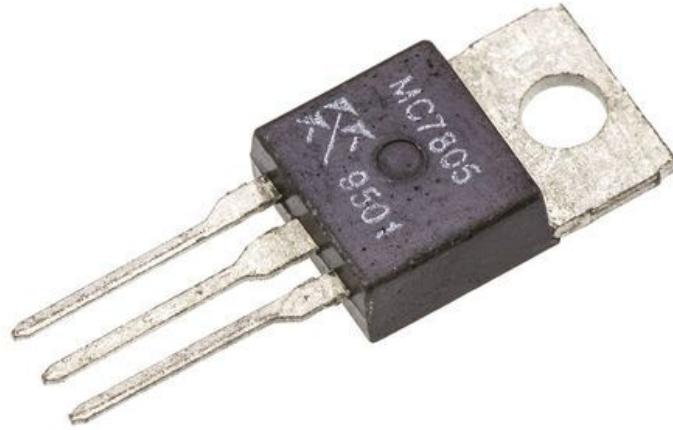
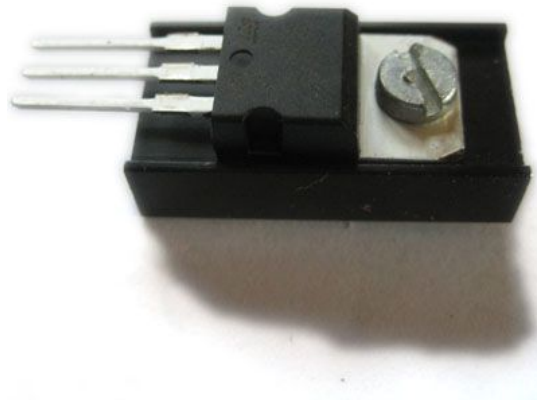

Figure 6. MC7805 with heat sink



Secondly, we designed the 12 V power supply using an integrate circuit LM338K. This type of voltage regulator gave us great degree of freedom at the testing and adjustment phase of the whole design process. Output of LM338K can adjust from as low as 1.2 V to 32 V. Although we set up the requirement to be 12 V output, we could have needed to adjust the voltage powering up the electromagnet if the the quality of the handmade electromagnet had certain variation. Figure 7 shows a picture of the LM338K integrated circuit we used. LM338K has two pins, one being input and the other being the adjustment pin. The output of this integrated IC is on the outer shell. Reviewing the requirements tells us there should be two ports outputting 2 A of current respectively. The current rating for LM338K integrated circuit is 5 A, so LM338K qualifies to have a position on our power supply circuit board. Figure 8 shows the circuit diagram of the circuit regulating 12 V DC voltage. The capacitors in parallel with LM338K is

smoothing the voltage wave and the variable resistor is for adjusting the output voltage. The value of resistor R2 is assigned by the datasheet of LM338K voltage regulator.

Figure 7. Illustration of LM338K



Figure 8. Circuit diagram of 12 V power supply

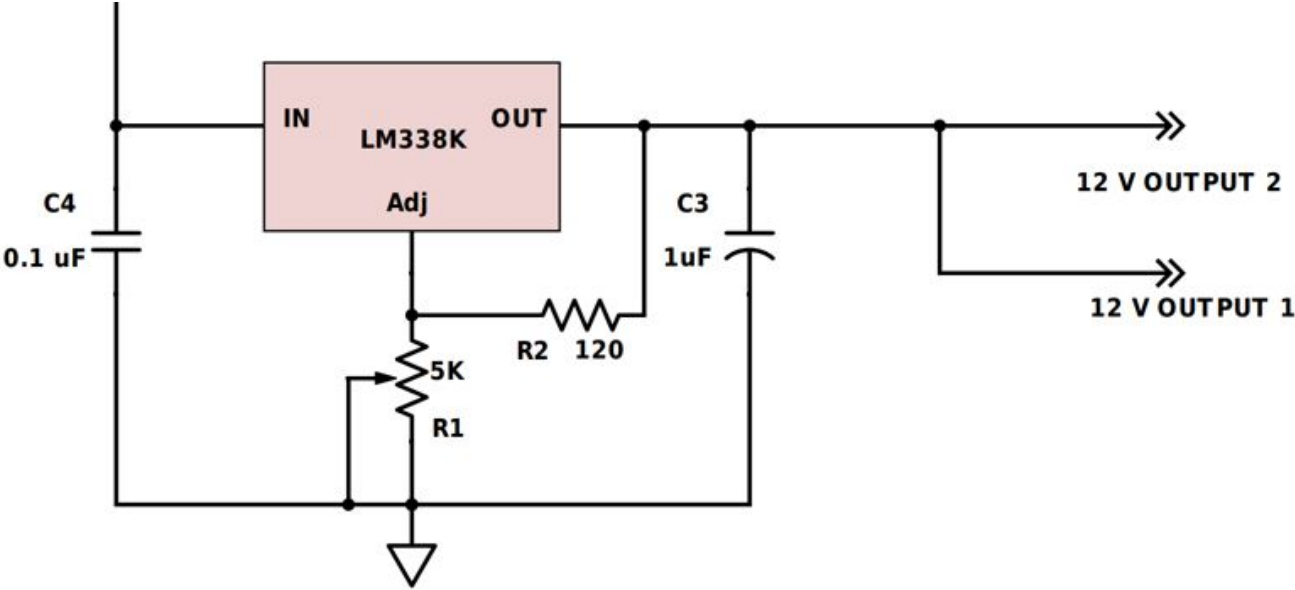

## 3. Design Verification

### 3.1 Physical Display

The physical display of the design was, essentially, the front-end of our project. It was here that any activity would be witnessed. Verification on this portion of the project was usually trivial, and amounted to no more than qualitative observations.

#### 3.1.1 Particle Board Scaffold

The particle board scaffold was responsible for holding the permanent magnets (and, to an extent, the electromagnets) in place. It was able to do both of these things though, unfortunately, it introduced an element of uncertainty (detailed in our conclusion) to our design.

#### 3.1.2 Plexiglass Container

The plexiglass container was responsible for holding the ferrofluid in a leakproof manner, all while allowing the ferrofluid within to be manipulated by our permanent magnets. Initially, the container was able to do both of these things (again, just through visual observation). However, our container sustained damage before our demonstration, and was no longer leakproof when we presented it.

#### 3.1.3 Spools and Backboard

The spools and backboard were responsible for holding the electromagnets in place, and in parallel. It was also imperative that the material used was not too prone to the effects of hysteresis, so the spools used iron while the backboard was made out of aluminum. Neither part exhibited significant amounts of magnetization during our tests (e.g. sticking magnets to them and seeing if they would subsequently be magnetized). The design and construction of these parts was also sturdy, so the structural integrity was never called into question

#### 3.1.4 Electromagnets

The electromagnets needed to be able to both repel and attract the permanent ceramic magnets, and needed to be able to do so with a current of no more than 4 Amps (absolute maximum) running through them. They also needed to have at least 3 ohms of resistance. Both of these needs were easily verified by hooking them up to the circuit and using a multimeter, respectively.

### 3.2 Power supply

The verification of the power supply module is fairly simple. We need to verify if the circuit outputs 5 V in the corresponding ports and 12V in the rest of ports. Figure 9 illustrates the setup for verification. We first ensure that the wall power outlet is giving 120 V with 5% error margin. Then we make the power plug of transformer connect to the wall power outlet and the output ends to an oscilloscope. Reading the result from the oscilloscope makes us know if the voltage output is up to specification. Table 1 gives the result of this verification and from the data shown. By the data collected, we ensure that the voltage output of this power supply fulfills the requirement.

Figure 9. Power supply voltage verification setup

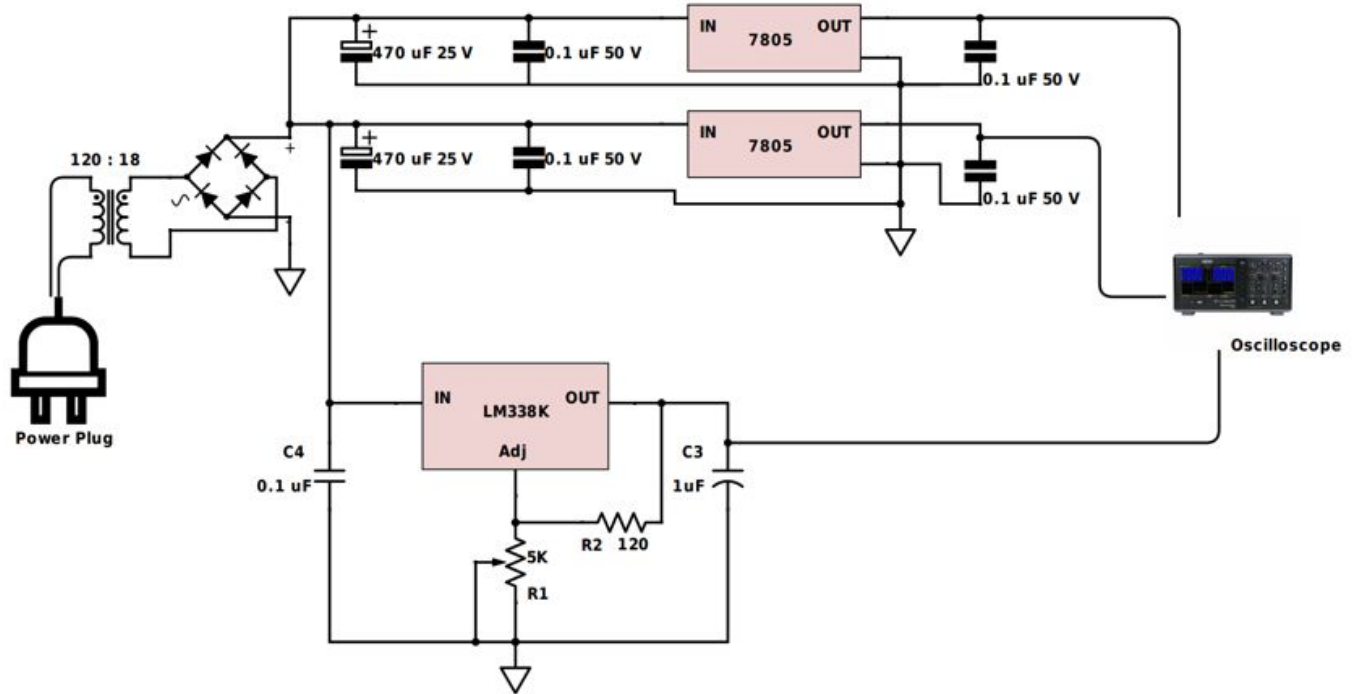

Table 1. Result of voltage verification

Output port	First time	Second time	Third time	Average
5 V (a)	4.97 V	4.99 V	4.92 V	4.96 V
5 V (b)	4.95 V	4.98V	4.99 V	4.97 V
12 V	11.8 V	11.9 V	11.9 V	11.87 V

In addition to the verification of voltage output, we need to verify the current output ability as well. Figure 10 gives a setup illustration of this process. Figure 10 only gives an illustration but not the actual connection. We connect power resistors afterwards the output end to draw the maximum design current from each of the voltage regulator integrated circuit and test if the current can consist without dropping or increasing. We used the multimeter to read the current. Table 2 gives the result of this verification and from the data shown, we ensure the power supply works according to the requirement.

Figure 10 Power supply current verification setup

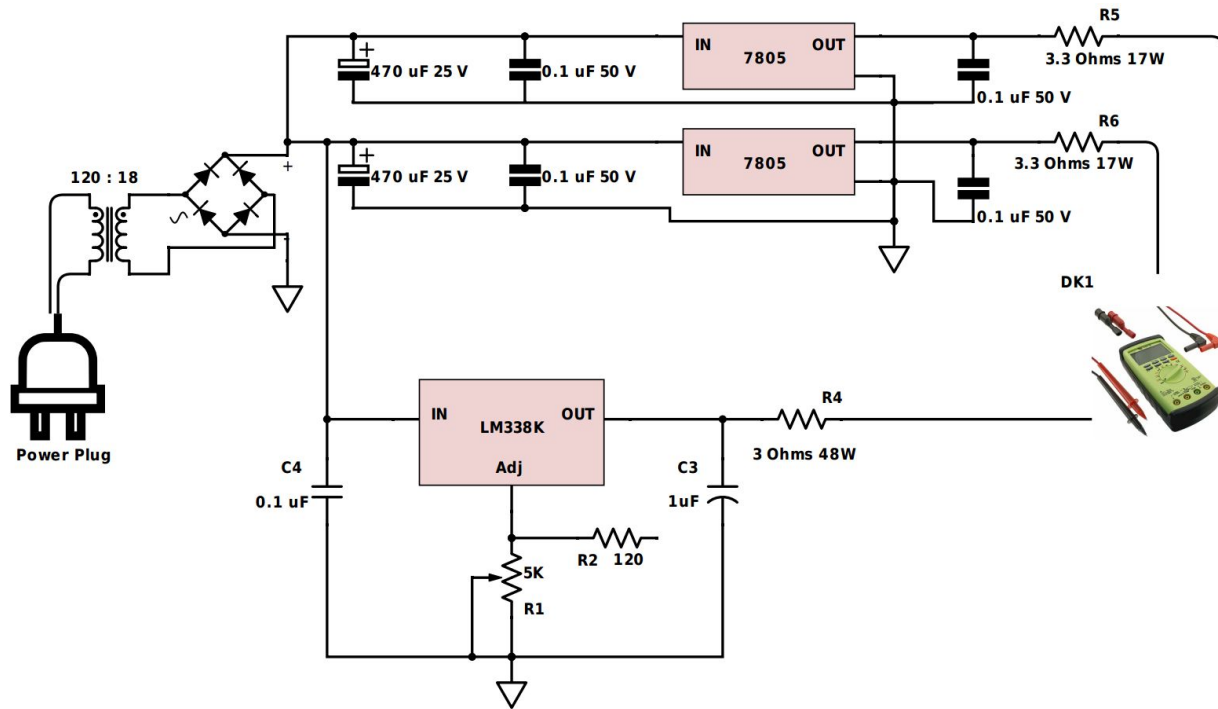

Table 2. Result of current verification

Output port	30 s later	1 min later	3min later
5 V (a)	1.53 A	1.48 A	1.45 A
5 V (b)	1.55 A	1.50 A	1.48 A
12 V	4.1 A	4.1 A	3.8 A

## 4. Costs

### 4.1 Parts

**Table 3 Parts Costs**

<b>Part</b>	<b>Manufacturer</b>	<b>Retail Cost (\$)</b>	<b>Bulk Purchase Cost (\$)</b>	<b>Actual Cost (\$)</b>
EFH1 Ferrofluid (60mL)	Amazing Magnet	19.5	2	38
Magnets (Size 12mm * 0.3mm)	Master Magnetics	0.6	60	36
Magnetic wire		12	2	24
Breadboard		10	1	10
Plastic glass frame	Machine shop	~12	1	12
Transformer	Arrow Electronics	9.5	1	9.5
Arduino Nano	Gikfun	4.5	3	13.5
				<b>Parts total: \$143</b>

### 4.2 Labor

**Table 4 Labor Costs**

<b>Team member</b>	<b>Hourly rate</b>	<b>Total hours</b>	<b>Total= Hourly rate X Total Hours</b>
Zhiyuan Yao	\$35	200	\$7000
Ting-Wei Tsu	\$35	200	\$7000
Hanyao Zhang	\$35	200	\$7000
			<b>Labor total: \$21000</b>

### 4.3 Total Cost

**Table 5 Total Costs**

<b>Parts total</b>	<b>Labor total</b>	<b>Grand total</b>
\$143	\$21000	\$21143

## 5. Conclusion

### 5.1 Accomplishments

We were ultimately able to create a circuit with exactly the behavior that we wanted. As will be mentioned in later sections, all the problems we ran into involved the physical aspects of the display.

Nonetheless, we were still able to achieve a portion of the expected display functionality; the display could create a zigzag of ferrofluid, and subsequently drop it. It was also able to drag up a single glob of ferrofluid, and any other design that required only five electromagnets, in positions 1, 3, 6, 8, and 11 on our arrays, beginning from the upper left with position 0.

### 5.2 Uncertainties

Due to the nature of our design (used electromagnets instead of mechanical linear actuators, our design was actually riddled with problems and general unpredictabilities. These included, but were not limited to, the effects of magnetic hysteresis, magnet-to-magnet attraction/repulsion, friction between the particle board and the magnets, and the effect of electromagnets on unintended targets (particularly neighboring permanent magnets).

In particular were the uncertainties surrounding friction and the shape of the permanent magnets, and the magnetic hysteresis.

The shape of the permanent magnets (many were poorly cut, where their faces and sides did not meet orthogonally), combined with the friction between them and the particle board, often caused the permanent magnets to get stuck in their tubes during actuation.

Magnetic hysteresis, meanwhile, damaged the permanent magnets, requiring that they be flipped over if actuation was to be continued.

### 5.3 Ethical considerations

Safety is the one of the most important concerns in creating our project; while what we hope to achieve with this project is more or less aesthetics, it goes without saying that we must also consider possible safety hazards in the design process.

First, the material we use needs to fulfill safety standards. We will use only a safe ferrofluid (that is, we will avoid using highly toxic, industrial grade products). Meanwhile, the fluid filled into the container along with the ferrofluid will not contain any hazardous materials. The seal of each container will be rigorously tested to ensure user safety and product usability. This last bit is particularly important due to the inherent volatility present when a fluid and electronics are in close proximity to each other.

Second, we considered the operation conditions and environment of the clock. Since the size of the clock will allow for desk use, we will use something like plexiglass for the outer shell to shatterproof the product to some degree. In addition, when the electromagnet arrays are in operation, current goes through the body of the clock and causes heat to be produced. In order to not burn the user, we considered either adding buffer material to the outer shell of the frame or to try to limit the maximum temperature the clock can reasonably reach. Note that the danger heat poses in our design is very low (that is, the display is *highly* unlikely to reach unsafe temperatures). Nonetheless, precautions must be made.

## 5.4 Future work

As hinted at in section 5.2, there are still a great deal of issues in the design that need to be solved. In our time working on the project, we were only able to create a single iteration. Due to the sheer number of variables dictating whether or not our design works, fixing the issues will require either a large number of iterations (that is, a good deal of trial and error) or very accurate modeling of the phenomena we witnessed.

Indeed, getting the display to work as a digital clock would require a lot of balancing. Otherwise, these questions, among others, would remain outstanding:

“If we increase the distance between magnets, would the ferrofluid still travel between them?”

“If we subsequently increase magnet strength, would the inter-magnet forces become too strong?”

“If we were to, then, increase electromagnet strength, would it affect its neighboring permanent magnets too much?”

Again, either testing or modelling would need to be done in order to both lay these questions to rest and to end up with a completely working design.

As for the problem of hysteresis, we believe that it can be solved using our software. We could do this by altering the magnitude of the current passing through an electromagnet during a single pulse to correspond with the distance between the electromagnet and permanent magnet. To account for other variables, such as heat, sensor may need to be added.

An unfortunate reality of all these possibilities for future work, however, is that the final working design may void our original intent of cutting down on the cost of the system.



## References

- [1] *Motorola Semiconductor Data Manual*, Motorola Semiconductor Products, Inc., Phoenix, AZ, 2007.
- [2] *Double Data Rate (DDR) SDRAM*, datasheet, Micron Technology, Inc., 2000. Available at: <http://download.micron.com/pdf/datasheets/dram/ddr/512MBDDRx4x8x16.pdf>
- [3] Linx Technologies LT Series, web page. Available at: <http://www.linxtechnologies.com/products/rf-modules/lt-series-transceiver-modules/>. Accessed January 2012.
- [4] J. A. Pruffrock, *Lasers and Their Applications in Surface Science and Technology*, 2nd ed. New York, NY: McGraw-Hill, 2009.
- [5] W. P. Mondragon, "Principles of coherent light sources: Coherent lasers and pulsed lasers," in *Lasers and Their Applications in Surface Science and Technology*, 2nd ed., J. A. Pruffrock, Ed. New York, NY: McGraw-Hill, 2009, pp. 117-132.
- [6] G. Liu, "TDM and TWDM de Bruijn nets and shufflenets for optical communications," *IEEE Transactions on Computers*, vol. 59, no. 1, pp. 695-701, June 2011.
- [7] S. Al Kuran, "The prospects for GaAs MESFET technology in dc-ac voltage conversion," in *Proceedings of the Fourteenth Annual Portable Design Conference*, 2010, pp. 137-142.
- [8] K. E. Elliott and C. M. Greene, "A local adaptive protocol," Argonne National Laboratory, Argonne, IL, Tech. Rep. 916-1010-BB, 2006.
- [9] J. Groeppelhaus, "Java 5.7 tutorial: Design of a full adder," class notes for ECE 290, Department of Electrical and Computer Engineering, University of Illinois at Urbana-Champaign, 2011.

## Appendix A Requirements and Verifications Table

**Table 6 System Requirements and Verifications**

Requirement	Verification	Verification status (Y or N)
1. The display does not consume more than 10 Watts at any given time over 2 hours of continuous operation.	1. Measure the voltage and current at a shared entry point (i.e. point of origin for all arduino boards) while the clock is running and confirm power never exceeds the required amount.	Y
2. The power supply provides 5V +/- 0.25V	2. Plug the power supply into the AC power outlet and set the AC input to range from -5% to +5% of 110V and check if the output is within the required range using a multimeter. Repeat at beginning of operation, ten minutes after operation and half an hour after operation.	Y
3. Ferrofluid can be moved to any required "pixel" on the display. Being on a pixel constitutes the presence of ferrofluid covering at least a 1 cm diameter around the center of the generated magnetic field from a forward-facing view.	3. Display all possible shapes of digits on each display and check using a ruler placed on the face of the display that all "on" pixels have the required amount and position of ferrofluid over it. Note that precision is not particularly important in this portion of our verification.	Y/N
4. Each pixel in the display will not hold more ferrofluid than 1.5 times 1/13th of the total ferrofluid in compartments 1,2,4, and 5, or 1/2 of the total ferrofluid in compartment 3.	4. Display all potential shapes on each display (i.e. 0-9, : ) as well as all possible transitions. We will measure the sizes of all ferrofluid "pixels" in every case, checking that it is within tolerable levels. Size will be calculated from volume.	Y/N
All compartments of the display are leak-proof and can withstand a reasonable amount (tentatively 20 pounds) of trauma during common indoor use.	Drop from 2 meters of height and pressure test from all sides of the outer shell can be done on the compartments. We will test in high/low temperatures to stress the sealing material. High temperature means 113 degrees and low temperature means 30	Y

	degrees. We will apply around 30 KG of pressure on each side and then use dyed water to do leakage test.	
The maximum time required to change numbers on the display does not exceed 15 seconds.	Test every possible transition (e.g. 1 to 2, 5 to 6) 10 times each. Measure how long each transition takes and ensure that no trials fail the requirement.	Y/N
Required programs fit within our microcontrollers' memories. That is, program and data size must not exceed 15 KB (this allows a 1 KB cushion).	Inspect the program size to check if the size meets the requirement.	Y
Number of electromagnets comes out to 52, each with 200 loops of wire around iron cores.	Simply count the total number of electromagnets across all arrays when complete, and maintain a count of loops in all electromagnets as they are wound.	N
Magnitude of the current through any operating electromagnet averages at .2 A, +/- .01 A.	Using a multimeter, measure the current entering (or leaving, as it may be) an operating electromagnet at the very beginning of operation, 5 minutes after continuous operation and 15 minutes of continuous operation. Find the average over all the measures and confirm that the obtained value falls within our required range.	N
Dimensions of the frame fall within 28 x 12 cm	Measure the dimensions of the frame using a meterstick for three times, and take the average of all the measurements. Compare the average with the required dimension.	Y

Note: Many verifications are listed as Y/N because, while they were not strictly met, became obsolete as our design progressed.