

CPAP Performance Verification Device

Team Members: Joseph Latocha, Zichong Wu, Joe Zinnen

ECE 445 Project Proposal

TA: Kexin Hui

1 Introduction

1.1 Objective

The CPAP (continuous positive airway pressure) device is the world's most popular non surgical option to treat obstructive sleep apnea [1]. When a person has obstructive sleep apnea, his/her airways may relax to the point where their breathing becomes obstructed, thereby reducing the amount of oxygen that reaches his/her brain and other vital organs. If not treated, sleep apnea can lead to health problems that range from minor afflictions such as headaches to more serious issues which include high blood pressure, heart failure, depression, or even stroke [2]. The basic working theory behind a CPAP device is that a constant pressure can keep airways from collapsing. It provides this pressure by use of a pump that delivers air into a hose that connects to a mask that is sealed around either the nostrils, or the nose and mouth of a person [3]. The CPAP must provide the correct amount of pressure that reaches the respiratory pathways to work. Currently there are CPAP machines that record information about how often the device is used and whether or not a person using the device has suffered from any apnea related events during the night, but they are typically the higher end models that are much more expensive. These exclusive models also require analysis and consultation by a physician.

Most CPAP machines are not built with a device that allows the user to directly access information about the pressures they output throughout an entire sleep period. This is problematic because people are unaware if they are actually receiving the pressure they require to treat their obstructive sleep apnea effectively [4]. If someone with obstructive sleep apnea does not realize they are not getting the pressure they require, they could not only have spent money on a machine that's ineffective, but they would also still be struggling with the effects of sleep apnea. For these reasons, we propose to make a device that verifies the CPAP machine is operating correctly. The device we propose should be able to sample air pressure so that the maximum and minimum air pressures are recorded to an accuracy of 3%. Once the maximum and minimum values are sampled, the data should be exported to an external device that will then process the information, and convert it to a readable format.

1.2 Background

A quick google search will reveal several sleep apnea sufferers who have experienced a defective CPAP machine [5]. For every user who can recognize a faulty product, we are concerned there are even more who are oblivious to a malfunctioning machine. As previously stated, only upscale CPAP machines collect and store data about the functionality of the

machine. Even with a high-end machine, accessing and understanding this data can be troublesome (if not impossible) for those who are not technicians, and since not all insurance companies cover the higher end CPAP models, we proposed that we would make a cheaper attachment to the hose that would gather information about the pressure of the device throughout a person's sleep cycle. There are also manual, handheld devices that test the pressure of the CPAP, but they do not provide the user of the CPAP machine with the ability to check if their CPAP machine lost pressure at any point during their sleep cycle. There is currently no device on the market that can provide a sleep apnea patient with accurate and thorough data throughout his/her sleep cycle at a low cost. Without direct access to this information, it is possible that one never realizes that their device is not operating correctly, and they could still unknowingly continue to suffer from obstructive sleep apnea.

1.3 High Level Requirements

- The verification device should be as cheap as possible, in no case should it cost more than 50% of a CPAP machine
- Information from the pressure sensors must be able to be accessed and analyzed each night for a full sleep cycle using an integrated circuit (6-8 hours, preferably even longer). The data stored by the IC should be simple to understand and displayed graphically
- The user must be alerted if there is any irregular activity throughout the sleep period so he/she can access the data.

2 Design

2.1 Design Overview

2.1.1 Hardware Design:

The backbone of the hardware design is based around the three pressure sensors. We decided three pressure sensors was the correct amount to use in order to test the machine because it allows us to place one in the breathing mask, one in the middle of the tube, and one closer towards the machine. The sensors will be connected to an integrated circuit that stores the pressure data. When the data does not fall into the range of a fully functional CPAP machine, the IC will turn on a red LED to let the user know something is wrong. A voltage regulator is necessary to guarantee that the correct voltage drop is being applied across the different components of the device. The device will also power a green LED when it is collecting data to let the user know the device is working. Power to the verification device will be supplied by a wall outlet. In addition, there will have to be an AC to DC power supply converter for the outlet

to voltage regulator connection. Below is a block diagram for our hardware design. The red connections represent power lines while the green connections represent data lines.

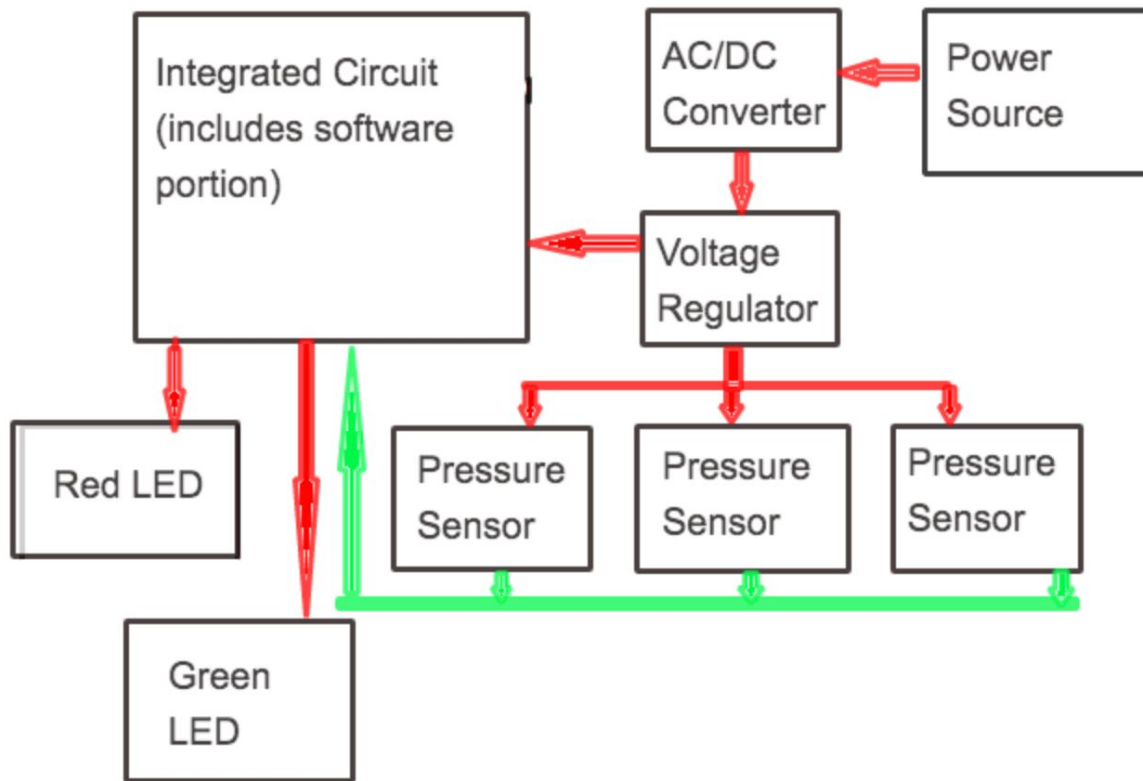

Figure 1: Hardware Block Diagram for CPAP Verification Device

Below is the expected physical representation of our proposed design. The power source (large black wire) plugs into a wall outlet and goes into our verification machine. The verification machine (grey box on top of CPAP machine) analyzes data from the three pressure sensors and turns on/off the red and green LEDs depending on that data. The pressure sensors are represented by the three small grey dots in the CPAP breathing tube.

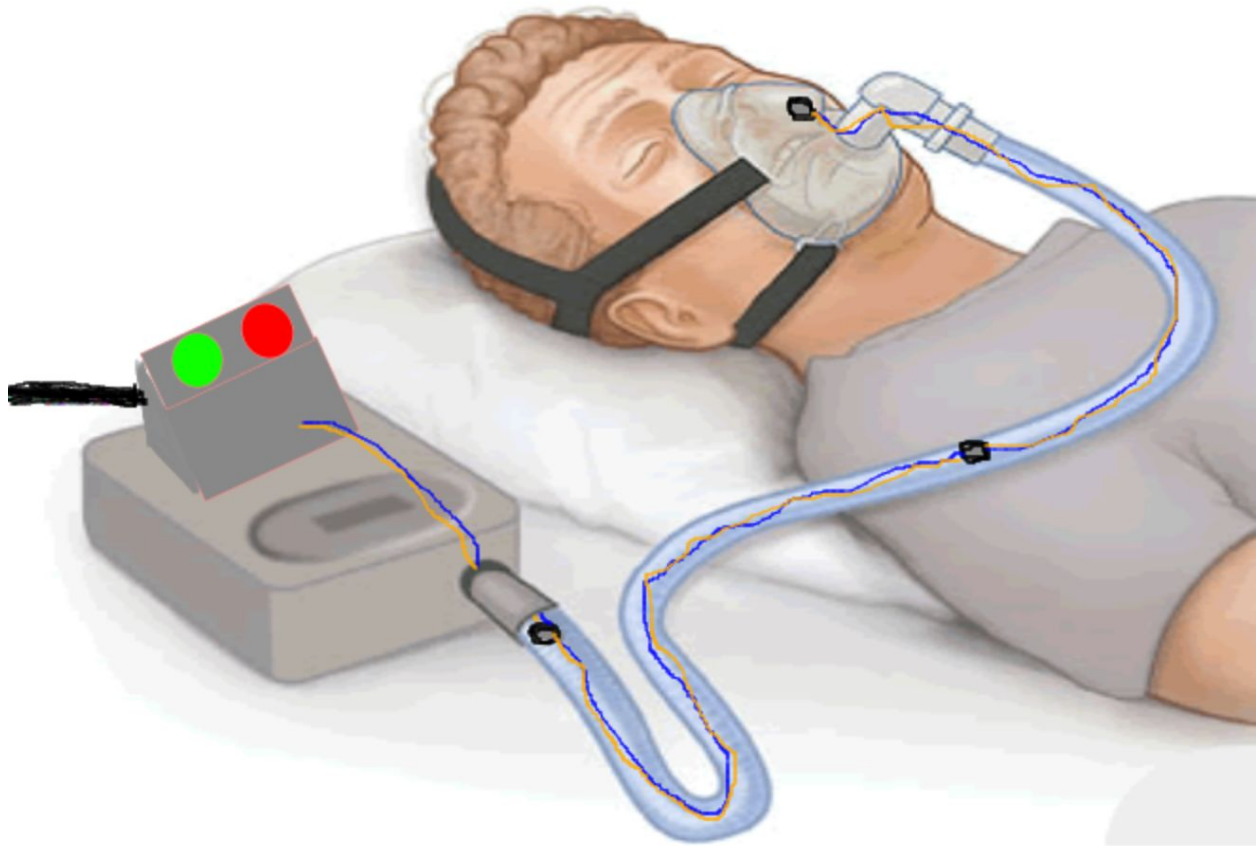

Figure 2: Physical Representation of CPAP Verification Machine

2.1.2 Software Design:

The software part of the design is to perform communication to the hardware design, aka the IC and the array of sensors, provide high level observation and allow high-level operation like viewing results directly and intuitively. This part is the highest abstraction level, in fact the user level, of the entire project. Users or TA's can examine and assess the entire CPAP performance verification device via this interface level.

The software should store data collection on the hosting device(either smartphone or computer). It should store at least 7 days of CPAP performance data and give tool to compare them as well as provide statistics like average maximum and average minimum pressure of the CPAP. When the current day value is over or under some thresholds, the software can perform operation to notify users that CPAP is underperforming.

For the operation part. The following is the list of the functionalities contained:

Pairing: Establish communication with the hardware device and become the hosting device of the unit (permission to receive data)

Turn On/Off Collection: When turned on, the data recorded on the IC unit will be sent to this hosting device. When turned off, the current hosting device will not receive any data

Pairing: Establish communication with the hardware device and become the hosting device of the unit (permission to receive data)

Delete: delete the specific day of readings

Alert: sends a notification to the hosting device when the performance is under a threshold required. Or requires the hardware LED(if mounted) to flash.

Adjust IC Settings: Sets the communication period (for example, sets the IC to send data to host every one hours), and sets the specific number of a periods of data that IC buffers.

Expected User Interface of the Design:

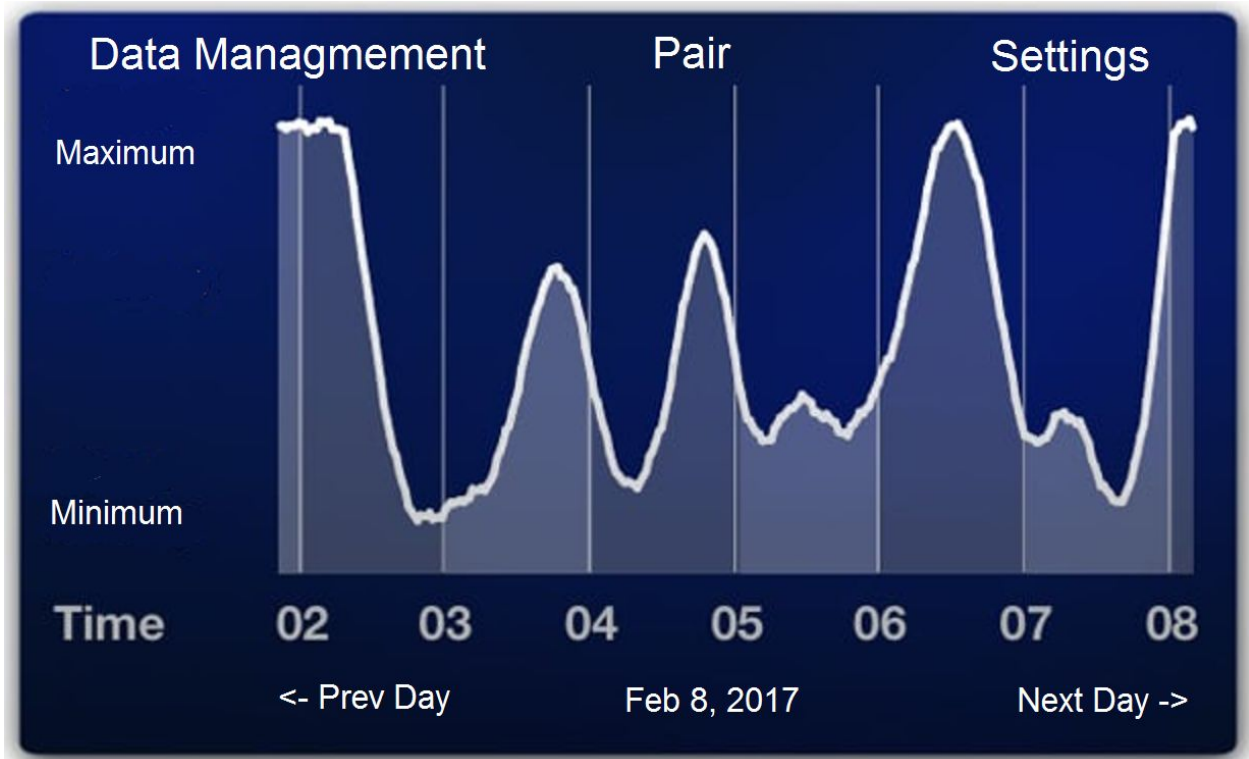

Figure 3: Preview of the interface and functionalities [6]

Block Diagram of Software Design

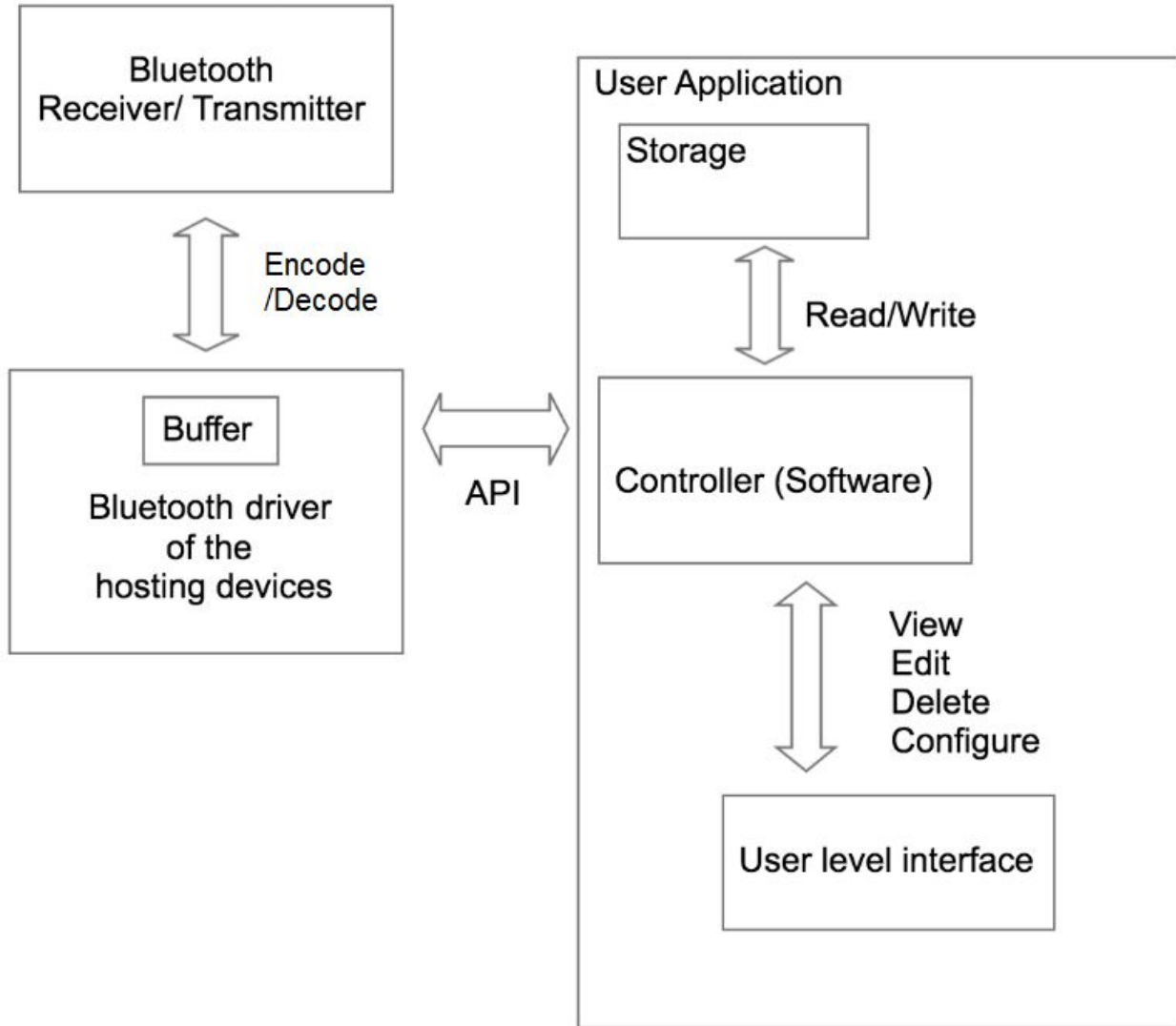

Figure 4: Software Block Diagram for CPAP Verification Device

2.2 Design Components

2.2.1 Power Supply

The sensors and IC will need to be powered by an external source to avoid the possibility of shorting out any CPAP components. The most logical way of supplying power indoors is using the 120V outlets that are most common in the United States, because a typical CPAP machine already plugs into the wall. It will also be controlled by a button to turn on and off the device.

Requirement: The device we build/obtain should be able to plug into a typical 120 V AC outlet found in a household.

2.2.2 AC/DC Converter

Since these lines are supplied by an alternating current, and we will require a constant voltage source, we will need to incorporate an AC/DC converter.

Requirement: The converter must modify the 120 V AC to 120 V DC to properly power the verification device.

2.2.3 Voltage Regulator

Each component of the verification device must be powered properly to function correctly. A voltage regulator is necessary because it ensures that there is not too much voltage across any element of the circuit causing it to short out.

Requirement: The voltage regulator must apply the correct voltage drop across each individual hardware element, as listed on each component's data sheet.

2.2.4 Pressure Sensors

The three pressure sensors are the most important part of the verification device. Each pressure sensor is attached to a different location in the breathing tube of the CPAP machine. One sensor is attached to the mask, one sensor is attached to the middle of the tube, and the last sensor is attached near the CPAP machine. The three different placements of the sensor will hopefully give us the more accurate pressure readings during the sleep cycle.

Requirement: The pressure sensors should sample air pressure (6-20 cm H₂O column) at a rate sufficient to detect maximum and minimum values during each breath cycle to within +/- 3 percent.

2.2.5 Status LEDs

Two status LED's indicate whether the verification device is working correctly (green LED) and if the data obtained is problematic (red LED). The green LED will be on constantly if the pressure sensors are consistently providing information and the device is connected to a smartphone. The red LED turns on if the pressure sensors return data that is not in the expected range of the breath-in or breath-out cycle. If the red LED is on after a sleep period, the CPAP user should observe the IC data. If the red LED does not turn on after a sleep period, the CPAP machine performed ideally.

Requirement: The IC must supply the LEDs with power when the correct functions occur. The green LED must stay on for the full amount of time the circuit is functioning correctly. The red LED must stay on throughout the sleep period until the user turns the machine off. Even if a pressure sensor records undesirable pressure for a few seconds, the red LED must stay on to alert the user.

2.2.6 Integrated Circuit

Bluetooth receiver/transmitter module:

Since this module will be built in consumer level products. The reliability will be as high as average consumer electronics.

Requirement:

Sending/receiving failure rate under 5%

Data corruption rate should be lower than 1%

2.2.7 Software

(a)Bluetooth Driver/API:

This part of design will be using code from existing libraries, with modification.

The maintenance cost is expected to be low.

Requirement:

Successful communication except rare condition occurs

Operation failure rate under 1%.

(b)Application block:

The application will be designed and implemented by us. The platform used is Android.

Requirement:

Controller: Expecting pairing time under 1 minute. (1)Storage reading, verifying, writing, (2)setting configuring, and (3) data retrieving should has a failure rate under 1% response time under 2 second

Storage: storage should not be lost under normal usage

User Interface Level: Operation Response under 1 second

3 Risk Analysis

3.1 Hardware Risks

There are several concerns with the hardware components of the design. Risk analysis is based on the probability of a failure occurring, as well as the magnitude of consequence once a failure does occur. Given these two important parameters, we have deduced that the most important hardware risks our project creates are

- (1) Impeding with the functionality of a fully working CPAP machine
- (2) Faulty pressure sensors yielding incorrect data to the user
- (3) Moisture from the breathing cycle of the user could cause circuit irregularity/breakdown
- (4) Power surges or incorrect design methods can cause circuit breakdown and danger the user

We can account for and prevent risk (1) by attaching the pressure sensors carefully and correctly. The wires running to and from the pressure sensors should absolutely not change the designated pressure for each breathing cycle chosen by a robust CPAP machine. Running small wires through the pressurized tube must have a minimal impact on the change in pressure compared to a tube without wires running through it. We can account for risk (2) by rigorously testing the pressure sensors in varying environments to ensure that they display the correct results in all cases. Risk (3) can be accounted for by covering any open wires or circuit parts with water resistant coating (such as rubber). The increase in the number of pressure sensors from one to three should also prevent any irregularities. If one pressure sensor has been corrupted by moisture, the user can cross reference the data with the other two sensors to see if it is actually a problem with the sensor or the pressure supplied by the machine. Risk (4) is very worrisome because it could cause a housefire. Our verification device must maintain a safety standard that is applicable to any household appliance. We must spend extra time consulting with engineers who have experience in power supply safety to minimize this risk.

3.2 Software Risks

There are three potential issue in the software design:

- (1) The possible risk will be corrupted data during transmission which can lead to abnormal data.

- (2) And unsuccessful reception leads to missing of a few readings over a night period.
- (3) Unstable connection between the host and the IC.
- (4) Software Driver/API issue

The solution will be to configure IC to buffer readings for a longer period of time for later verification of the data (e.g. resent last few readings with the current reading to the host). That way the host will identify discrepancies. This will solve the (1) and (2) issue.

The (3) connection issue of bluetooth module will requires more thorough analysis and controlled environment to identify any possible issue. Simple packets (strings of 0's or 1's) or an one-day sample of data can be used in the testing/debugging environment. Then we can start from this working state to implement features.

The last potential issue (4) will be relatively simple to solve using IDE and modern software debugging tool.

Since the software application will be developed and installed on devices that are already being tested for reliability, the software failure caused by hardware issue (like storage failure of the smartphone) will be unlikely to happen. Also, with the developed platform (Android) will provide good modularization for testing and maintaining purposes.

4 Ethics and Safety

There are some safety concerns that need to be addressed. Since exhaling into a tube will naturally add more humidity into the tube, the circuit elements will have to be kept dry to prevent any shorts from occurring. Parts of the circuit could also be covered in non-permeable material to prevent humid airflow from damaging it. In addition, the tube attachment size will have to be consistent with the rest of the tube to keep the pressure consistent with a normal breathing cycle for the CPAP user. It is imperative that the verification device does not interfere with the normalized pressure in the breathing tube. If our design somehow lowers the designated pressure for the tube, it will most likely make the user's sleep apnea worse instead of better. Shorts are a particularly worrying safety concern. If any part of the circuit shorts out, It could not only ruin the verification device, but it could also potentially start a fire that destroys a user's home, or even worse, result in death.

The application software should not have access to lower level resources of the IC (like power, transmitting control). If the software can cause failure of the IC, this can lead to damage of the verification device and potentially the CPAP. Also, if the software has design flaws that cannot reflect the underperformance of the CPAP machine in some circumstances, the user of the

verification can be misguided unknowingly which can cause uncomfortably and undesired sleep experience of the patient and other potential consequences.

We must stay focused on our goals for the project. We have to be concerned with the safety and reliability of the verification device, not with finishing the project quickly or turning a profit. The safety of the user is to the utmost importance to us. We intend to follow the IEEE Code of Ethics [7] for all unforeseen future ethical dilemmas (in addition to dilemmas we have already addressed).

References

[1] G. H. Gibbons, "How is Sleep Apnea Treated?," in *National Heart Lung and Blood Institute*, Department of Health and Human Services, 2012. [Online]. Available: <https://www.nhlbi.nih.gov/health/health-topics/topics/sleepapnea/treatment>. Accessed: Feb. 4, 2017

[2] "7 hidden dangers of obstructive sleep apnea," in WebMD, WebMD, 2016. [Online]. Available: <http://www.webmd.com/sleep-disorders/guide/understanding-obstructive-sleep-apnea-syndrome#2>. Accessed: Feb. 4, 2017.

[3] K. Phillips, "CPAP therapy: How it works, getting set up, & results," in *Alaska Sleep Clinic*, 2014. [Online]. Available: <http://www.alaskasleep.com/blog/what-is-continuous-positive-airway-pressure-cpap-therapy>. Accessed: Feb. 5, 2017.

[4] "CPAP," in *National Heart, Lung, and Blood Institute*, 2016. [Online]. Available: <https://www.nhlbi.nih.gov/health/health-topics/topics/cpap>. Accessed: Feb. 5, 2017.

[5] B. Peters, "Signs Your CPAP Machine is Not Working Anymore to Treat Sleep Anymore," in *Verywell*, 2016. [Online]. Available: <https://www.verywell.com/signs-your-cpap-is-not-working-3015051>. Accessed: Feb. 7, 2017.

[6] B. Warner, Image retrieved from "Measure The Quality Of Your Sleep With The Sleep Cycle App", 2014. [Online]. Available: <http://www.bitrebels.com/apps/measure-quality-sleep-cycle-app/>. Accessed: Feb. 7, 2017.

[7] IEEE Code of Ethics [Online] Available: <http://www.ieee.org/about/corporate/governance/p7-8.html> Accessed: Feb. 8, 2017.

