

Design Document

Anti-freeze Water Pipe System

Team #12
Team Members:
Qinru Li
Rui Lan
Zichen Liang
TA: **Eric Clark**
March 11, 2017

1 Introduction

1.1 Objective

We notice a fact that during the winter when the room temperature is low, the water pipe will become frozen. Frozen pipe has a high risk of bursting. This is a huge trouble if there are no people at home to deal with the problem immediately. We believe it would be helpful if there is a system that can both heat up the water pipe externally and notify the user when the water pipe is about to be frozen.

To design the system, we first need to monitor the temperature around the water pipe. When the temperature is below the threshold, a heating system will start heating the pipe above a certain temperature to prevent the pipe from freezing. Meanwhile, the system will use a Wi-Fi module to inform the user about this issue.

1.2 Background

The water pipe is an essential housing installation to every house or apartment. Although the pipes seem to be robust, a lot of people have the experience that in a harsh winter the water pipes are easy to be frozen and burst. If this situation happens, not only the water supply will be cut off along with the apartment getting flooded, but also extra time and money are needed to repair the pipe. We searched online and found there is a kind of heating cable sold well on Amazon [1]. From the comments, we noticed that the main reason people are all willing to buy it is they are trying to heat up their water pipes during the winter. However, this system is purely manual controlled, which means it cannot work when no people are home. Also, people cannot know the emergency happens when no one home. We came up with an idea to design an integrated system to detect the temperature, process the data, heat up the pipe, and notify the user. In this way, we can save a lot of human work and make the system more reliable and safer.

1.3 High-level Requirements List

- Our system must prevent water in a 1.5-meter long pipe from freezing.
- Our system must be easy to install and disassemble, allowing householders to use the system.
- Our system must be reliable. When blackout happens, there is an alternative battery source which will keep the system functioning.

2 Design

2.1 Block Diagram

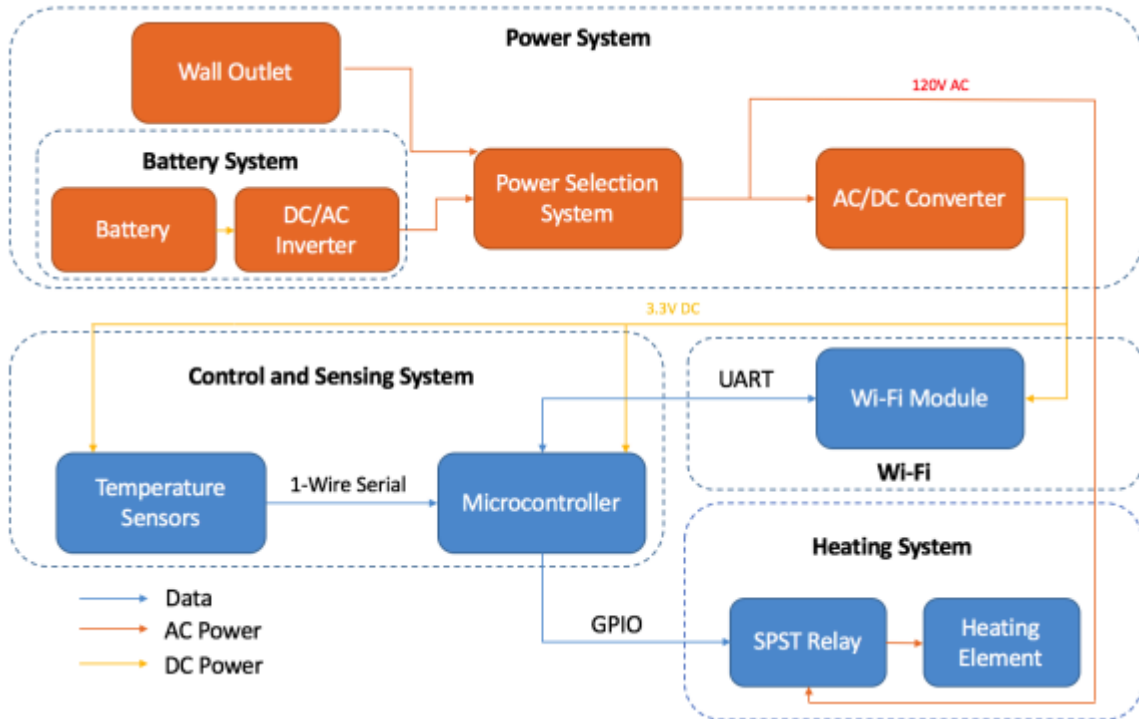

Figure 1. System Block Diagram

2.1.1 Temperature Sensor

The first part of the system is sensing system. We plan to use temperature sensors to get the related information from the pipe and pass the data to the controller which will control the Wi-Fi module and the heating system. We plan to use the DS18B20 temperature sensors from Maxim [2] which can detect the temperature change in the worst case of 0.5°C accuracy (with 9-bit bus) in the range of -10°C to 85°C. The input of this sensor is a DC voltage from 3.0V to 5.0V. We plan to feed 3.3V DC voltage into the sensors using the output of the AC/DC converter. The output of the sensor is a 9-12 bits Celsius temperature measurement. The measurement resolution is programmable. We choose to use the 12-bit output bus to pass the temperature information to the controller. In this situation, the precision of the temperature sensors is 0.0625°C which is the maximum precision the sensor could reach.

To improve reliability, we plan to use two temperature sensors which will be placed at the top and the bottom of the pipe (as the physical design part shows). The data from both the sensors will be reported to the controller, and the controller will use the average temperature as the reference of control decision.

$$T = \frac{T_{bottom} + T_{top}}{2} \quad \text{Eq. 1}$$

We will stick waterproof tape around the water pipe to protect the sensors from wet conditions. Also, we should be careful not to let the heater directly heat temperature sensors,

which can mess up the measurement. Therefore, we put sensors in a fair amount of distance from the heater to prevent mismeasurement.

The circuit diagram of the temperature sensor part is shown below. We need to connect the data bus with a 4.7kΩ pull-up resistor as required on the datasheet [2].

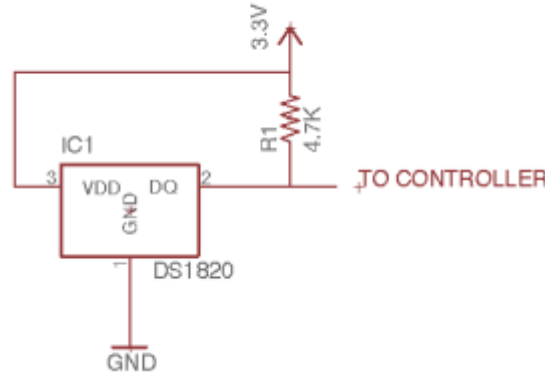

Figure 2. Temperature Sensor Schematic

Table 1. Temperature Sensor PIN Assignment

PIN Name	Detail
VDD	3.3V DC from AC/DC Converter
GND	Ground
DQ	Data bus connected with a 4.7kΩ pull-up resistor for data transition

In terms of the wiring with the microcontroller, the DQ pin in the temperature sensor can connect to any digital pin in the microcontroller. In our case, we pick PIN4, PIN5 for each DQ in the sensor.

1-Wire Bus Protocol

The communication to the temperature sensor is through 1-wire protocol. 1-wire bus protocol use a single bus master to control multiple slaves. The DS18B20 is always a slave. The transaction sequence of data communication is as follows:

- a. Initialization.

The initialization starts by a reset pulse transmitted by the bus master. The bus master will pull low the bus. Then it follows by a presence pulse transmitted by the slave(s).
- b. Send ROM Command.

The ROM command allows master to determine how many and what kind of devices are present on the bus. There are five kinds of ROM command, with each of them 8-bit long: SEARCH ROM, READ ROM, MATCH ROM, SKIP ROM, ALARM SEARCH.

To read temperature data from the sensor, we will need READ ROM, MATCH ROM and SKIP ROM. The description for each command can be find in the datasheet [2].
- c. Send Function Command

After the master uses ROM command to determine the DS18B20 which it wishes to communicate, it will issue function command. Function command allows master to read from and write to the sensor. To read temperature data from sensor, we first need

Convert T command which initialize the temperature measurement in the sensor. Then we repeat the 1-wire bus protocol and use Read Scratchpad command to read the data from sensor.

R&V [10 points]

Requirements	Verifications
<ol style="list-style-type: none"> The controller can use 1-wire protocol to communicate with the sensor and acquire the temperature data. 	<p>Verification of Time for Adjustment</p> <ol style="list-style-type: none"> Attach the temperature sensor to a desk. Follow the transaction sequence as describe above to communicate with the temperature sensor. In the first 1-wire bus communication, use SKIP ROM Rom command and Convert T function command to instruct sensor to initialize the temperature conversion. In the second communication, use SKIP ROM Rom command and Read Scratchpad function command to read the temperature data. Connect the microcontroller to PC with Arduino board, once the microcontroller receives the data, print out the temperature data in Arduino console. Use an infrared thermometer to measure the desk temperature. Compare its result with the printout in the Arduino console, the printout data should be close to the infrared thermometer data.

2.1.2 Controller

The control system is the decision-making center of our system. It collects data from the temperature sensors and instructs the Wi-Fi module and the heating system. The controller will determine when to send the pipe-freeze information to the user and when to start or stop heating the pipe.

The controller will receive inputs from temperature sensors. When the water pipe's temperature is lower than 4°C, the controller will start the heating system. When the temperature is above 7°C, the controller will stop the heating system. This way, we can prevent the whole system from overheating.

The controller will pass the real-time temperature information to the Wi-Fi module which will publish the message to the user.

We plan to use ATmega328P [3] as our microcontroller because this kind of controller is easy to program and low power-consuming. ATmega328P supports various Arduino libraries which provide us multiple opportunities and convenient platforms to develop our software. The required power supply of this microcontroller is 1.8-5.5V. We plan to use the 3.3V DC voltage from the AC/DC converter to power it up.

Circuit Schematics:

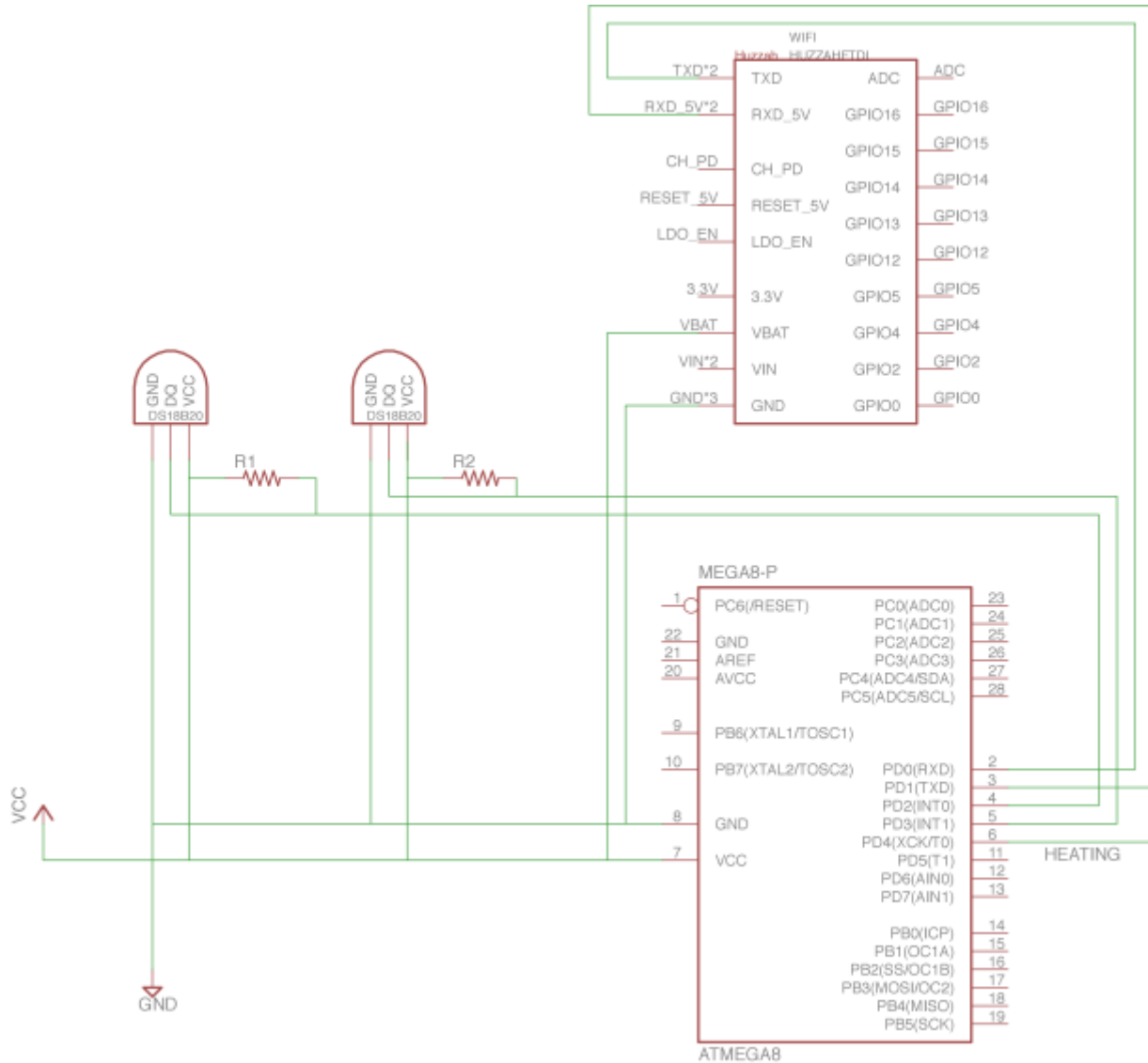

Figure 3. Control Circuit Schematic

Software Flowchart:

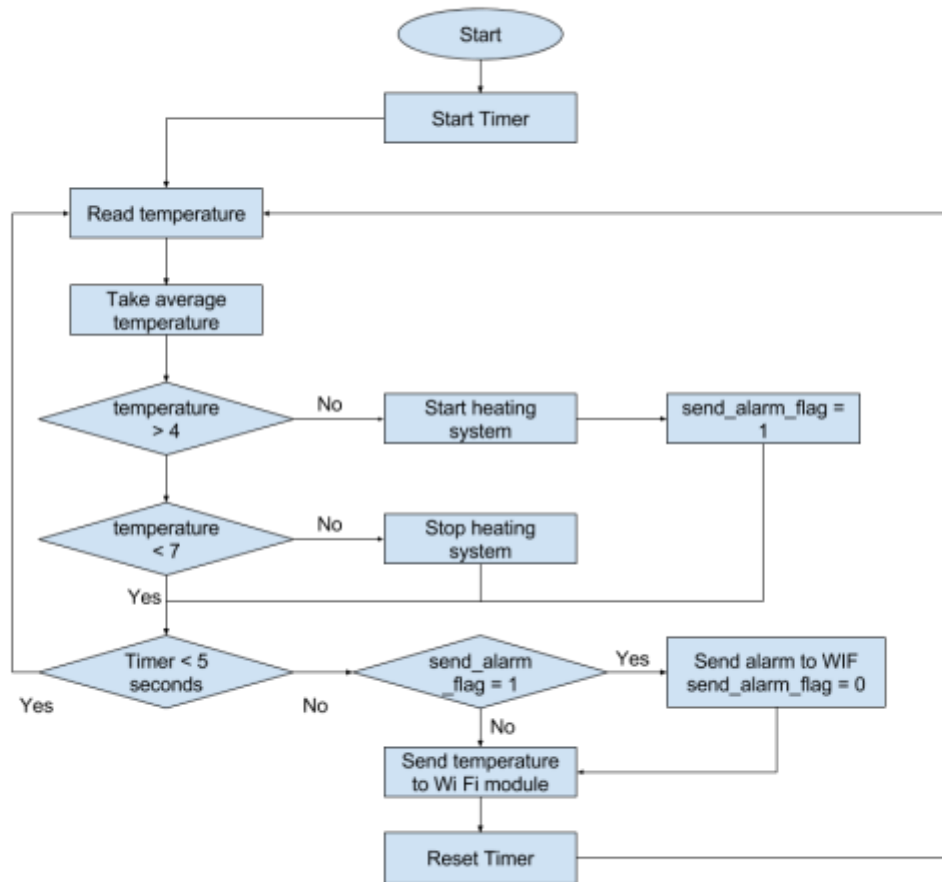

Figure 4. Software Flowchart

Flowchart Explanation

After the controller is initialized, it will first start the timer and read the temperature data from sensors, then it takes an average of the measurement. If the measured temperature is below 4°C, the controller will start the heating system and mark the alarm signal flag as 1. If the measured temperature is above 7°C, the controller will turn off the heating system.

After this, the controller will check the timer. If the timer duration is more than 5 seconds, the controller will start sending the currently measured temperature data to the Wi-Fi module and the alarm if necessary. Otherwise, the controller goes back to the read temperature state and control the heating system. Only when the data is sent to Wi-Fi, will the timer be reset. This flowchart ensures system has a quick response to the change of temperature while doesn't send too much data to online broker.

R&V [10 points]

Requirements	Verifications
<ol style="list-style-type: none"> 1. The controller should sample the temperature data at least 1Hz. 2. Microcontroller can send temperature data to Wi-Fi module at least every 5 seconds. 3. The controller can turn on the heating system when the temperature is below $4^{\circ}\text{C}\pm 0.5^{\circ}\text{C}$ and can turn it off when the temperature is above $7^{\circ}\text{C}\pm 0.5^{\circ}\text{C}$. 	<p>Verification of Sampling Data</p> <ol style="list-style-type: none"> 1. Microcontroller uses 1-wire bus protocol to read the temperature data from temperature from the sensor. Once it receives the 2-byte temperature from sensor, it turns on an I/O pin in the controller. Here we pick the I/O pin to be pin 11. 2. Microcontroller uses 1-wire bus again to read the temperature. Once it receives it, it turns off the pin 11. 3. Microcontroller keeps repeating the step 1,2 above. 4. Measure the pin 11 output signal in the oscilloscope, the frequency should be at least 0.5Hz. <p>Verification of Sending Temperature Message to Wi-Fi module</p> <ol style="list-style-type: none"> 1. Use a python stopwatch software to monitor the data sent from the Wi-Fi module. The software will also use MQTT protocol and connects to the online broker 2. Use the stopwatch software to measure the time duration between it receives every data from the Wi-Fi module. The time duration should be less than 5 seconds. <p>Verification of Correct Timing of Switching Heating System</p> <ol style="list-style-type: none"> 1. Emulating the 1-WIRE protocol by using another Arduino act as the DS18B20 slave 2. Master issues the reset bit. Slave response with an acknowledge bit. 3. Master issues the data read command. Slave doesn't acknowledge. 4. Then Slave send 9-byte pre-programmed data to Master and. 5. Repeat above steps for 3 scenarios:

	<p>when the temperature data sent is below 4 degree, when the temperature data sent is between 4 to 7 degree, when the temperature data sent is above 7 degree.</p> <ol style="list-style-type: none"> 6. Connect a LED in series with the heating system. Observe its behavior, when the LED is off, it means the heating system is off. When the LED is on, the heating system is on. 7. From the first to the second scenario, the LED should be on. From the third to the second scenario, the LED should be off.
--	---

2.1.3 Wi-Fi Module

The Wi-Fi module is a device that sends data to remote users. It will publish real-time temperature. When the water pipe is about to freeze, it will also send an alarm signal to users. We plan to use Adafruit Huzzah ESP8266 [4] as the Wi-Fi module. It connects the microcontroller through UART protocol and temperature information will be provided by the microcontroller.

The Wi-Fi module will be set as a network client and use MQTT protocol to publish data into the online server. We pick two candidates for the server: Amazon AWS or HiveMQ broker. Both provide similar MQTT interfaces. In the PC, we plan to design a software as a client that subscribes to the message published by the Wi-Fi module. This software will be our demo as the user-end interface of the entire anti-freeze water pipe system.

Physical Layout for Adafruit Huzzah ESP8266 [4]

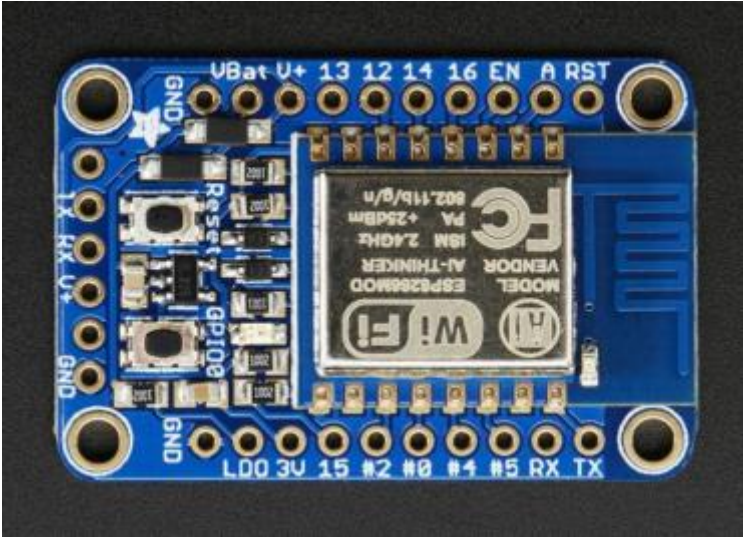

Figure 3. Layout for Wi-Fi Module [4]

Important Pins

- V_{Bat} : The power supply of the entire circuit board, which will be connected to the 3.3V DC from the AC/DC converter.
- GND : The GND pin in the power supply. There are several GND pins in the layout. They are connected to each other. We can pick any one.
- TX : TX pin for UART communication. It will connect to the RX pin in the microcontroller.
- RX : RX pin for UART communication. It will connect to the TX pin in the microcontroller.

Software Client

A software client will be built in PC with Python. This software will connect to the MQTT server and subscribe to the topic which the Wi-Fi module will publish to.

R&V [5 points]

Requirements	Verifications
<p>1. The Wi-Fi module must be able to send a real-time temperature data to the online server at least every 5 seconds.</p>	<p>Verification of Wi-Fi Module Frequency</p> <ol style="list-style-type: none"> 1. Use the temperature sensor to measure the room temperature. Use a thermometer to measure the room temperature as a reference. 2. Use microcontroller to send the sensor's data to the Wi-Fi module. 3. Use a stopwatch app designed in Python on a PC to read the data Wi-Fi module sent to the MQTT online server. 4. The stopwatch app print out the data it receives and the time duration between it receives every data. 5. The data should be close to the data measured by the thermometer in Step 1 and the time duration should be less than 5 seconds.
<p>2. The software in the PC can be able to receive the same temperature data sent from Wi-Fi module.</p>	<p>Verification of Software Client</p> <ol style="list-style-type: none"> 1. The controller will keep sending a counter to the Wi-Fi module which starts from 0. 2. Create a MQTT software in python that subscribes to the topic Wi-Fi module publishes to. 3. Once the software receives the data, it

prints it out immediately in the console. An array of consecutive digital number should be displayed in the console.

2.1.4 Heating System

The main function of our project is to heat the pipe. The way to heat the pipe is using heating element locating outside the water pipe. The heating material we use is silicon rubber bendable heating element [5]. The 110V to 120V AC voltage (either from battery system or wall outlet) to support the heater is from the source that is selected from the power selection system (DPDT relay). The sensors located at the surface of the pipe would detect whether there is a need to heat the pipe. Based on sensors' signal, the controller switches the heater using an SPST (Single-pole, Single-throw) relay. We choose to use the PCB relay G5NB-1A(-DC5) from OMRON Corporation [6]. The reason of using SPST delay is to control a high voltage circuit (the 120V AC going into the heating system) using a low voltage circuit (the control signal generated by the controller, 5V DC in our system). By doing this, we can easily and safely control our heating system to keep the water pipe within a rational temperature region.

Since the operating current of SPST relay is 40 mA, and the output current of microcontroller is 40 mA, to protect the circuit, we choose to have a Common Drain (CD) (Source Follower) configuration of the MOSFET. The circuit diagram of CD MOSFET [17] is shown as below:

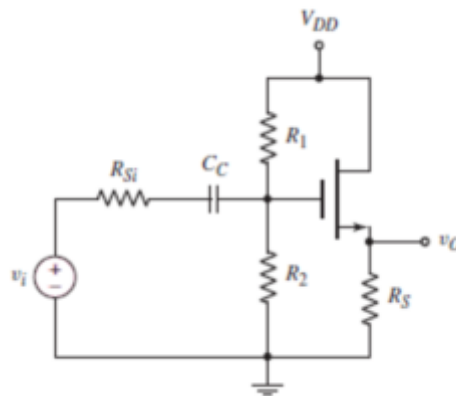

Figure 7. Circuit diagram of Common Drain MOSFET

The CD amplifier has a voltage of 1, which can pass the output voltage of controller to the coil of relay without change. Also, the CD amplifier can block the currents from the input stage and output stage, which protects our controller. To let the MOSFET works as a source follower, we need to choose DC bias to set it in the saturation region. The requirement of saturation region is: $V_{GS} > V_T$ and $V_{DS} > V_{GS} - V_T$. From the datasheet [17] of 2N7000 MOSFET we plan to use (available in the electronics shop), the threshold voltage V_T of the MOSFET is 2.1V. We can also choose the operation point from the output characteristic plot of the MOSFET on the datasheet [17].

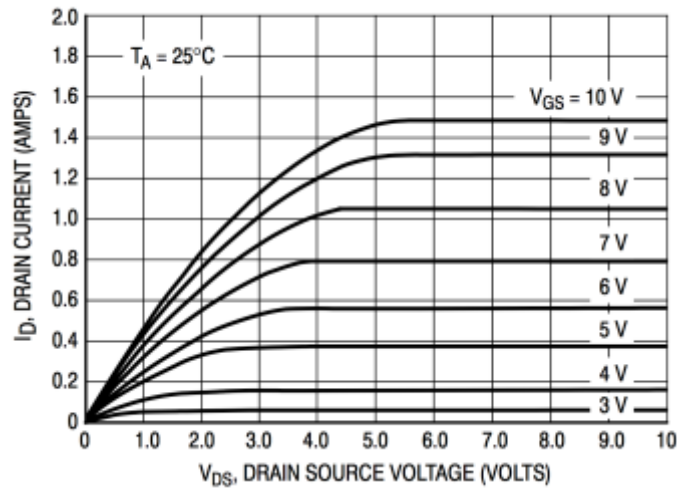

Figure 8. Output characteristic plot of the MOSFET

According to Figure 8, we find the point of $V_{GS} = 4V$, $V_{DS} = 5V$, and $I_D = 0.15A$ is a good work point for the MOSFET. It satisfies the requirements in the saturation region: $V_{GS} > V_T = 2.1V$ and $V_{DS} > V_{GS} - V_T = 1.9V$. We plan to use 10V DC voltage (VDD) to power the chip. (Further adjustment may be needed for the AC/DC Converter). The choice of R_1 , R_2 , and R_S are calculated as below:

$$V_S = V_{DD} - V_{DS} = 10 - 5 = 5V \quad \text{Eq.2}$$

$$R_S = \frac{V_S}{I_D} = \frac{5}{0.15} = 33.3\Omega \quad \text{Eq.3}$$

$$V_G = V_{GS} + V_S = 4 + 5 = 9V \quad \text{Eq.4}$$

Based on the value of V_G , we can use $R_1 = 1M\Omega$ and $R_2 = 9M\Omega$ to set the gate voltage to be 9V. We also need two coupling capacitors on both input and output stage to filter out DC component. The value of those two capacitors is 0.1uF by convention.

In our system, we decide to start heating the pipe when the temperature is below 4°C, and stop heating when the temperature is above 7°C. The relationship of the heating system with other systems is as the diagram below.

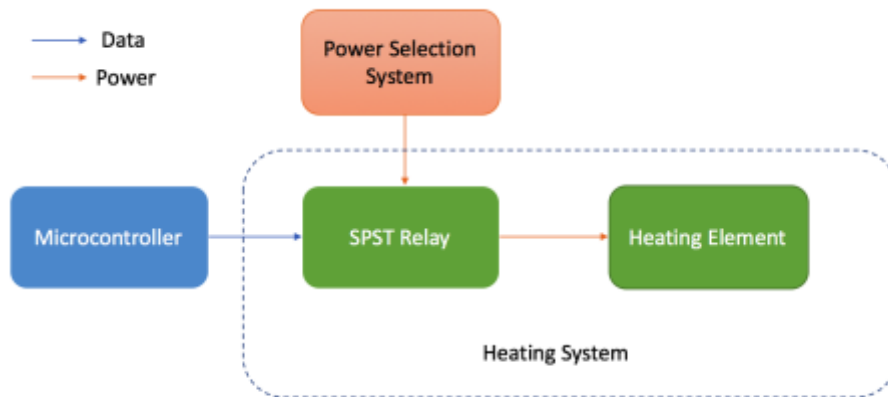
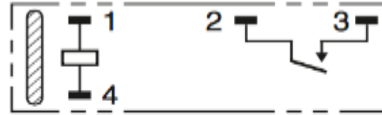

Figure 9. Heating System Block Diagram

SPST relay circuit diagram from datasheet [6]:

**Terminal Arrangement/
Internal Connections
(Bottom View)**

l.



(No coil polarity)

Figure 10. SPST Relay Circuit Diagram

Table 2. SPST Relay Connection

PINs	Connections
PIN 1	Connect to the signal generated microcontroller
PIN 2	Connect to power selection system (high)
PIN 3	Connect to power selection system (ground)
PIN 4	Connect to ground of the whole PCB

The heating element we plan to use [5] could give us 150W power by using 120V AC voltage to power it up. In this situation, the current passing through the heating element can be calculated as:

$$I = \frac{W}{V} = \frac{150W}{120V} = 1.25A \quad \text{Eq.5}$$

We understand this is a pretty large current value. However, we will need it to heat the water and the pipe which require a large power to do. We do the following calculation of the total amount of power needed to heat the water inside and copper pipe for 3°C.

1. To calculate the heating temperature of copper with a variance of $\Delta T = 3^\circ\text{C}$,
With the parameters of water pipe: Outer diameter (D_{Outer}): $\frac{13}{8}$ inch (0.041275 m), Inner diameter (D_{Inner}): $\frac{3}{2}$ inch (0.0381 m), Pipe length (L): 5 feet (1.524 m), we can get the mass of copper pipe (with the copper density: $\rho_{copper} = 8960 \frac{kg}{m^3}$):

$$m_{copper} = \pi((D_{outer}/2)^2 - (D_{inner}/2)^2)L\rho_{copper}$$

$$\text{Eq.3} = \pi \left[\left(\frac{0.041725}{2} \right)^2 - \left(\frac{0.0381}{2} \right)^2 \right] \times 1.524 \times 8960$$

$$= 2.66 \text{ kg}$$

Along with the heat capacity of copper C_{copper} is 390 J/kgK and we assume the heating temperature difference is $\Delta T = 3^\circ\text{C}$, the thermal energy Q is calculated as following:

$$Q_{copper} = C_{copper} \Delta T m_{copper} = 2.66 \times 3 \times 390 = 3112.45 \text{ J} \quad \text{Eq.6}$$

Then the heating time of water to raise 3°C would be:

$$t_{copper} = \frac{Q_{copper}}{W} = \frac{3112.45J}{150W} = 20.75s \quad \text{Eq.7}$$

2. As the heat conductivity of copper is 385 W/mK , which is a one of the best heating conduct material, we are going to assume the water will be heated as we heat outside of the copper. To calculate the heating temperature of water with a variance of $\Delta T = 3^\circ\text{C}$:
 With the parameters of water pipe: Inner diameter (D): 1.5 inch (0.0381 cm), Pipe length (L): 5 feet (1.524 m), we get the mass of water pipe (with the water density: $\rho_{\text{water}} = 1000 \frac{\text{kg}}{\text{m}^3}$):

$$m_{\text{water}} = \pi \left(\frac{D}{2}\right)^2 L \rho_{\text{water}} \quad \text{Eq.6} \quad = 3.14 \times \left(\frac{0.0381}{2}\right)^2 \times 1.524 \times 1000$$

$$= 1.74 \text{ kg}$$

Along with the heat capacity of water C_{water} is 4184 J/kgK , and we assume the heating temperature difference is $\Delta T = 3^\circ\text{C}$, the thermal energy Q is calculated as following:

$$Q_{\text{water}} = C_{\text{water}} \Delta T m_{\text{water}} = 1.74 \times 3 \times 4184 = 21463.92 \text{ J} \quad \text{Eq.8}$$

Then the heating time of water to raise 3°C would be:

$$t_{\text{water}} = \frac{Q_{\text{water}}}{W} = \frac{21463.92 \text{ J}}{150 \text{ W}} = 143.09 \text{ s} \quad \text{Eq.9}$$

$$t_{\text{total}} = t_{\text{copper}} + t_{\text{water}} = 20.75 + 143.09 = 163.84 \text{ s} \quad \text{Eq.10}$$

Thus, if we use this kind of heat material to heat up both the copper water pipe and the water inside, the total time will be 163.84s (approximately 3 mins). As the heat conductivity is not as ideal as we assume when we do the calculation, and there will be other power losses during the heating process, we expect our heating system could heat up the system for 3°C in 6 minutes.

Moreover, because this heating material externally attaches to the pipe, we must be cautious if the pipe leaks. The water coming from the water pipe will be dangerous if it splashes on the electrically heating material. Therefore, we decide to paste water-proof tape around the heater to prevent such emergency happens. Also, as we decided in the physical design section, we will add caps on both ends of the water pipe to prevent the pipe from leaking.

R&V [5 points]

Requirements	Verifications
1. The heater should increase the temperature of the water pipe at least 3°C within 6 minutes.	1. Verification Process for Item 1: (a) Use thermometer to measure the temperature of water pipe (b) Apply 5V DC to coil voltage, and 120 V AC to the input of the relay, and start to time using the timer (c) Ensure the temperature of the water pipe to increase at least 3°C within 6 minutes
2. The current of heating system should be less than 2A while operating.	2. Verification Process for Item 2: (a) Attach multi-meter to measure the current when passes the heating system (b) Apply 5V DC to coil voltage, and 120 V AC to the input of the relay (c) Ensure the current is always less than 2A through the heating process

2.1.5 Battery System

As we described in the high-level requirement list, we want our system to continue working even there is a blackout (harsh winter when the wall outlet power is not available). We use a 12V 7Ah rechargeable lead acid battery [7] for the backup power system. The reason we decide to use this battery is:

1) Safety issue. The battery utilizes Rugged Construction (Non-conductive ABS plastic), such that the device can avoid shock, vibration, chemicals and heat.

2) User friendly. The acid inside is absorbed between the plates and therefore immobilized by a very fine Fiberglass mat. This configuration allows customer to use in any orientation.

The battery then connects to inverter, which inverts 12V DC to 110 V AC voltage [8]. The inverted 110 V AC voltage will be another input of the power selection relay. The inverter we plan to buy from the website can provide 300W maximum power supply, which is enough for heater (consumes 150W) to work. The inverter then connects to heater complements as battery system.

R&V [5 points]

Requirements	Verifications
1. The battery system must work without power from wall outlet for at least 20 minutes.	1. Verification Process for Item 1: a) start the timer when the battery system starts b) stop the timer when the system stops c) make sure the operation time is at least 20 minutes

2.1.6 Power Selection (DPDT Relay)

Our power selection system aims to select the power supply from two sources to make our system more reliable even there is a power blackout. One input of the relay will be the power from the wall outlet, which is 110V-120V AC power. The other input of the relay will be the power of the battery system, which will also be a 110V AC power. To select the two sources of energy, we plan to use a DPDT (double-pole, double-throw) relay [9].

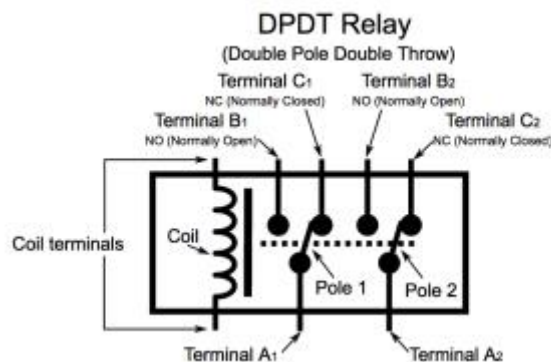

Figure 11. DPDT Relay Circuit [9]

The DPDT relay acts as a switch in the circuit. As the block diagram above shows, the inputs of the DPDT relay are B1, B2, C1, and C2 (for power sources B and C), and the outputs are A1 and A2, which is the selected power. To choose the power supply based on the existence of the wall power supply, we plan to connect the 110V power from wall outlet directly into the coil. When the coil voltage exists, the relay will choose wall outlets as the source of energy. Otherwise, the relay will choose the power from battery system to power up our whole circuit. The design requires the coil voltage is near 110V AC and both inputs can bear at least 120VAC voltage. We find the DPDT relay Z5357-ND from Omron is suitable for our design [10].

The coil voltage is 110VAC, and the maximum switching voltage is 380VAC (larger than 110VAC-120VAC). The circuit diagram from the datasheet [11] is shown below:

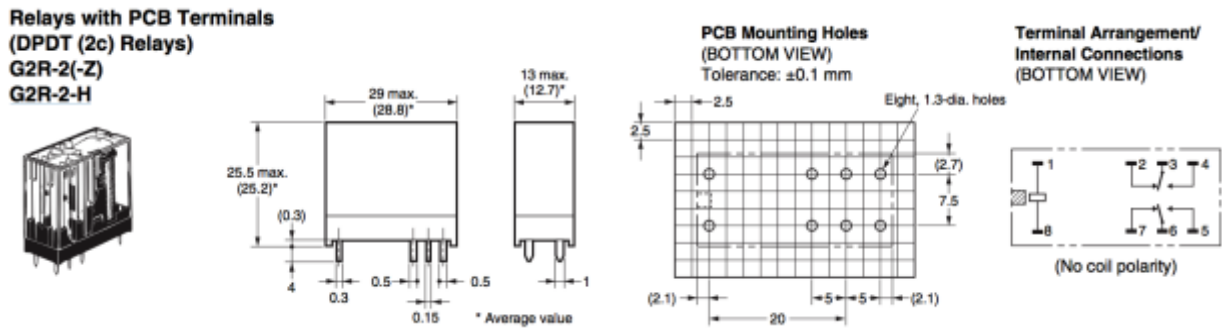

Figure 12. Z5357 Relay Datasheet [11]

Table 3. PIN Assignment of DPDT Relay

PINs	Connections
PIN1, PIN8	AC power coming from wall outlet (PIN1 for high, PIN8 for ground)
PIN2, PIN7	AC power coming from wall outlet (PIN2 for high, PIN7 for ground)
PIN3, PIN6	To the AC/DC converter and the heating system (PIN3 for high, PIN6 for ground)
PIN4, PIN5	AC power coming from the battery system (PIN4 for high, PIN5 for ground)

The output of relay (PIN 3 and PIN 6) will be connected to the AC/DC converter (for converting to DC voltage and then powering up the controller, sensors, and the Wi-Fi module) as well as the heating system (to provide heating power).



Figure 13. AC/DC Converter Block Diagram

For the transformer part, we decide to buy a transformer (MT2115-ND) available in the market [12], which can convert 115V AC to 10V AC (series connection) or 5V AC (parallel connection). We plan to choose to use series connection because of its lower complexity and to satisfy the input requirement of the voltage regulator (the voltage regulator requires input voltage larger than $2.5V + \text{output voltage} = 2.5V + 3.3V = 5.8V$). The primary side of the transformer will be connected to the output of the power selection circuit, and the secondary side of the transformer will be connected to next part of the AC/DC converter which is the rectifier. We plan to use the full-wave (bridge) rectifier to rectify our incoming AC voltage because it can rectify the both half-cycles of the AC voltage (thus, we can achieve a higher accuracy than half-wave rectifier). We are going to use the 1N4004 diodes which are available in the lab. To simulate the full-wave rectifier circuit, we assembled a circuit as below:

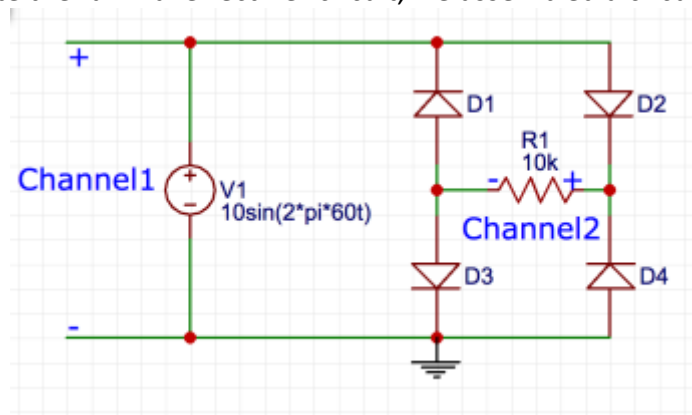

Figure 14. Test Circuit of Full-Wave Rectifier

The simulation result of channel 1 is as below:

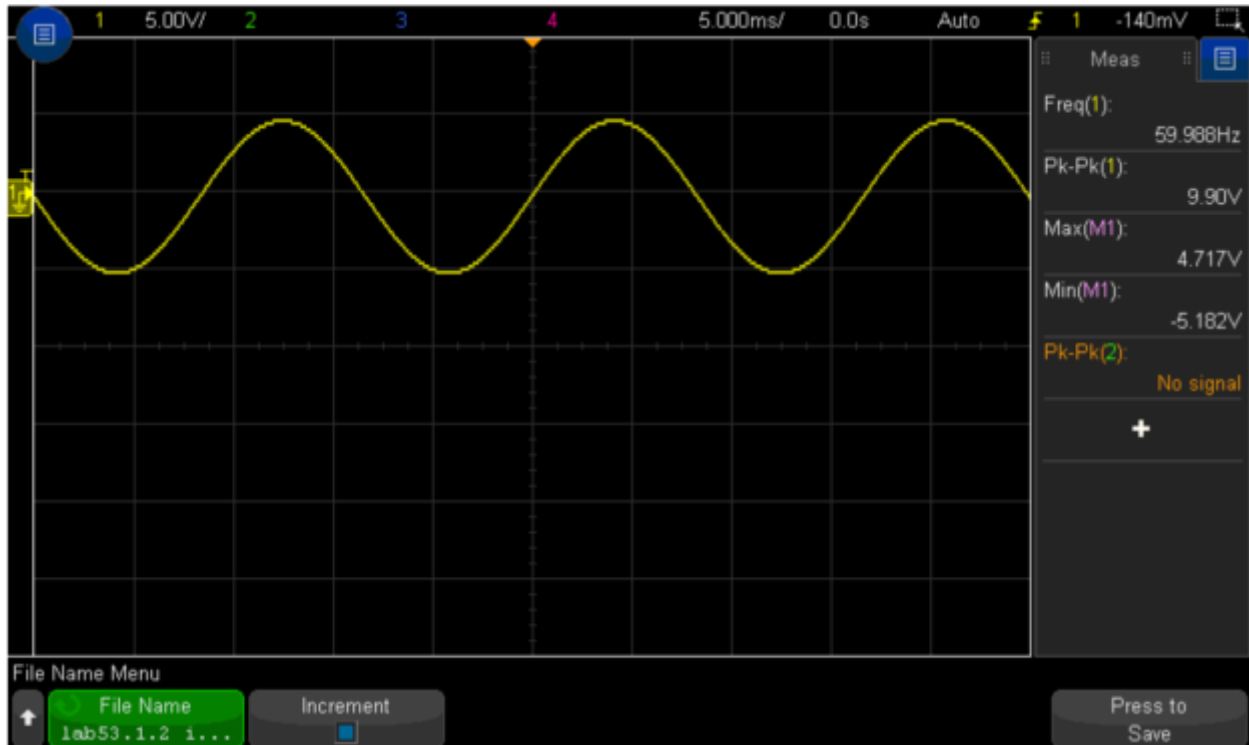

Figure 15. Input Signal of Test Circuit

The simulation result of channel 2 is as below:

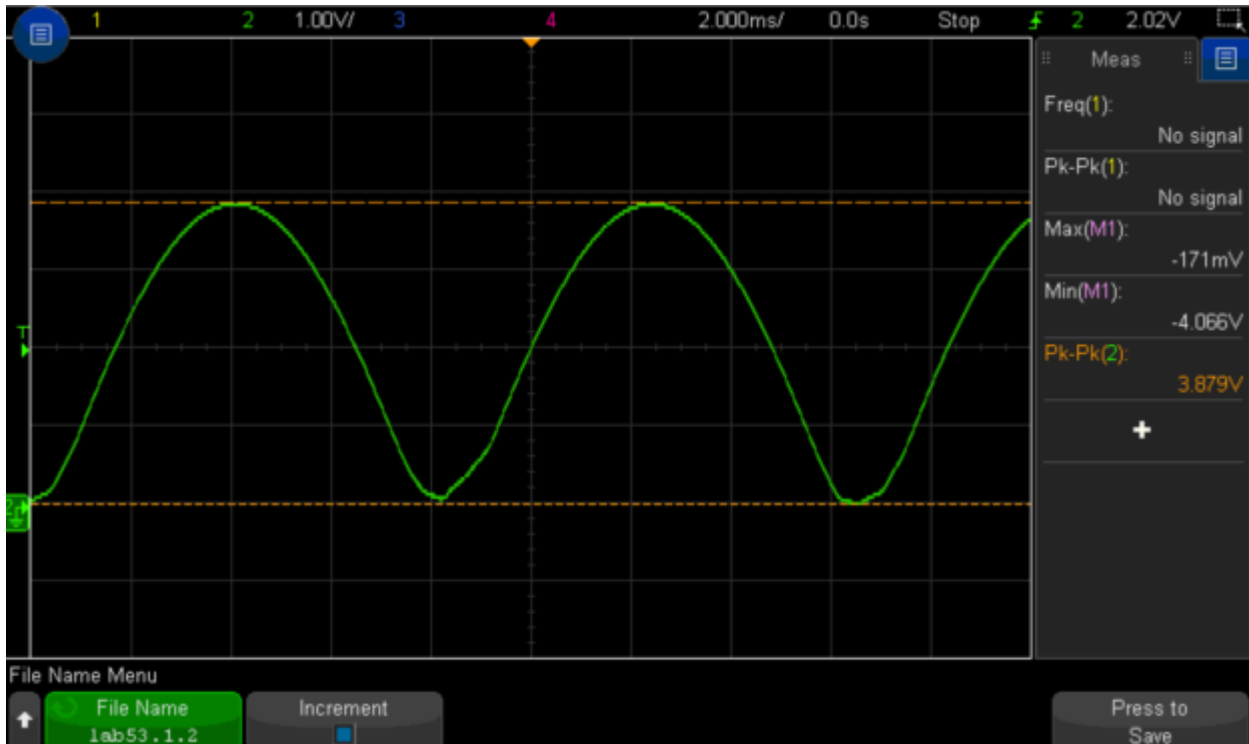

Figure 16. Output Signal of Test Circuit

As we can see, after the rectifier, the signal only contains the positive part and the signal of the whole period has been rectified.

We also need a smoothing capacitor after the full-wave rectifier to average the signal. The capacitor is required by the voltage regulator to perform correctly. The value of the capacitor can be determined by the voltage ripple on the capacitor, the load current, and the voltage signal frequency after the transformer. As the output of whole AC/DC converter can bear 10% ripple ($3.3V \pm 0.3V$), we assume the ripple on the smoothing capacitor to be 1V, which is 10% of the output voltage from the transformer. The load current is on the voltage regulator datasheet, which is 100mA. The frequency is two times 60Hz which is the frequency from the wall outlet. The reason why we need to double it is the full-wave rectifier rectifies both sides of the input voltage.

$$C = \frac{I}{fV_p} = \frac{100m}{2 \times 60 \times 1} = 833\mu F \quad \text{Eq.11}$$

There are 1000uF electrolytic capacitors available in the electronics shop.

After the smoothing capacitor, the voltage goes into a voltage regulator to obtain a stable 3.3V DC voltage. We plan to use the LM317L Adjustable Regulator from Texas Instruments [13] for this conversion. This kind of voltage regulator can convert the input DC voltage from 5.8V ($2.5V + \text{output voltage} = 2.5V + 3.3V$) to 32V into DC voltage from 1.25V to 32V. According to LM317L's datasheet [13], the circuit schematic of this voltage regulator is as:

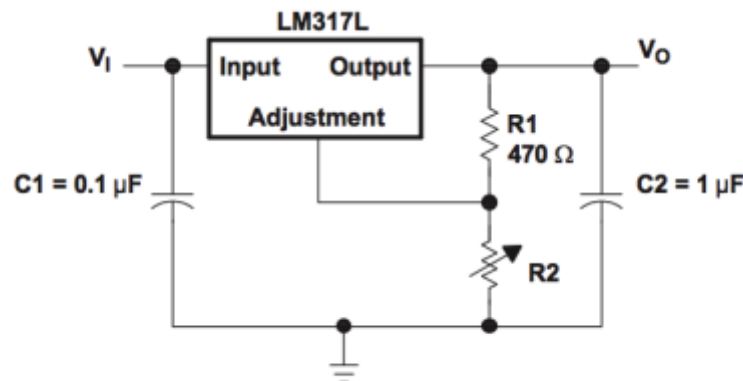

Figure 17. Circuit Schematic of Voltage Regulator

And the output voltage is determined by:

$$V_O = V_{REF} \left(1 + \frac{R_2}{R_1} \right) + I_{ADJ} R_2 \quad \text{Eq.12}$$

where $V_{REF} = 1.25V$, $I_{ADJ} = 50\mu F$ (which can be ignored), and $R_1 = 470\Omega$.

We can calculate R_2 based on the output voltage $V_O = 3.3V$ as our expectation.

$$\frac{3.3}{1.25} = 1 + \frac{R_2}{470}$$

$$R_2 = \frac{41}{25} \times 470 = 770.8\Omega$$

Also, the LM317L voltage regulator can ensure the output current is less than 100mA, which makes our AC/DC converter and the other systems safer and more reliable.

The circuit schematic of the AC/DC converter is shown below:

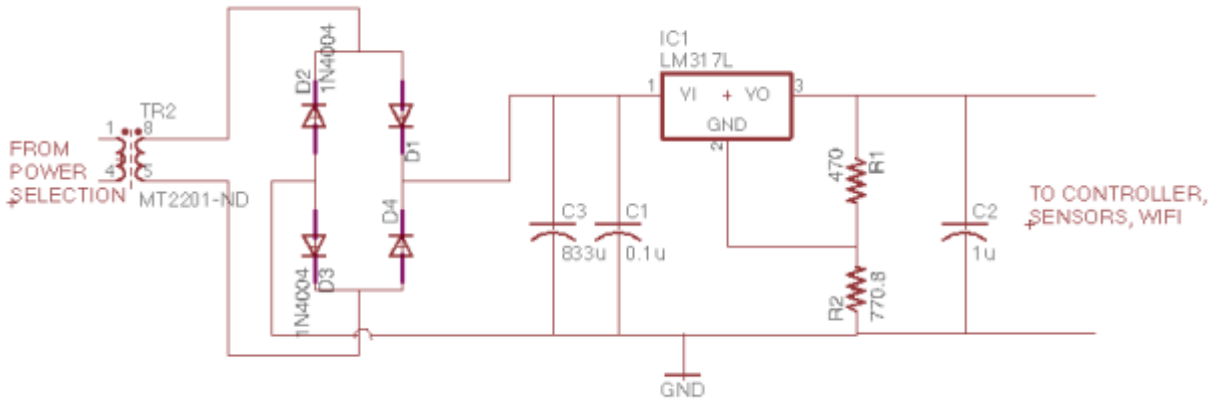

Figure 18. Circuit Schematic of AC/DC Converter

The output side of the AC/DC converter is going to be connected to the temperature sensors, the Wi-Fi module, and the controller.

R&V [10 points]

Requirements	Verifications
1. The output of AC/DC converter should be within the range of $3.3V \pm 0.3V$ at 100mA	1. Verification Process for Item 1: (a) Attach 33Ω resistor as the load (b) Attach an oscilloscope across the load (c) Supply AC/DC converter with 115VAC (d) Ensure the output voltage remains in $3.3V \pm 0.3V$
2. The output of the transformer should be AC voltage with in $10V \pm 1V$	2. Verification Process for Item 2: (a) Attach $10k\Omega$ resistor as the load (b) Attach an oscilloscope across the load (c) Supply the primary side of the transformer with 115V AC (d) Ensure the voltage on the secondary side remains in 9V-11V

2.2 Physical Design

The physical connection of our project is following:

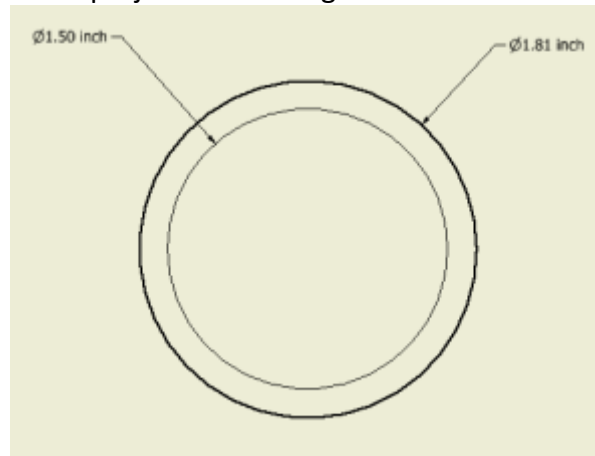

Figure 19. Water Pipe Cross Section



Figure 20. Appearance Sketch of the Water Pipe

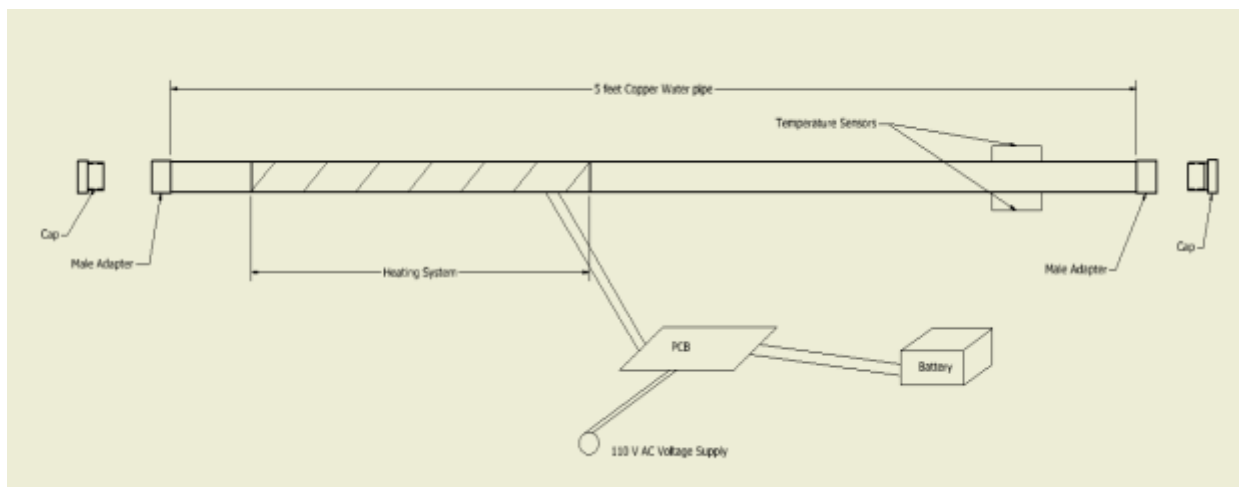

Figure 21. Physical Connection Diagram

We plan to use 1-½ inch or 1-inch diameter, approximately 5 feet long copper water pipe [14] with heating system winding around. The two temperature sensors are located at top and bottom part of the pipe respectively. To ensure the accuracy of collected temperature information, we will install appropriate insulator between our temperature sensors and the heating system. The placement of sensors is roughly 50cm apart from the heating system, which aims to minimize the error with the temperature data. For demo purpose, we plan to solder male adapters on both sides of the pipe. With threads inside, the caps will be installed on the both ends, which help us to demo the system (to easily fill the pipe with ice or water). Our controller, Wi-Fi module, and power selection system will be integrated on one PCB. The output from the power selection system will be connected directly to the PCB. The sensor will be installed on the pipe with insulation, and it will send data to the controller on the PCB and get power from the PCB.

2.3 Risk Analysis

First, we have a 120 VAC power source coming from the wall outlet and 12V DC from battery. The main process of our task is to convert electric energy into thermal energy. Therefore, it might impact the performance of our project if there exist some potential issues (e.g. the poor efficiency of DC to AC inverter and the low capacity of the battery) with voltage conversion and stepping up/down voltage.

An issue might take place on the temperature. Due to fact that the placement of the temperature sensor is outside the pipe, we can never acquire the exact temperature of the water inside the pipe. Great measurement error may lead to poor performance of our system.

The other major issue might take place on the part of the heating system. Since we heat the water pipe externally, it relates to the thermal conductivity of pipe material, as well as the material of the heater. A potential pitfall is that the heating process takes long time to heat up the pipe.

2.4 Tolerance Analysis

According to Solar-Facts.com, a website that provides people many power-conversion related information, “Efficiency may vary from something just over 50% when a trickle of power is being used, to something over 90% when the output is approaching the inverters rated output” [15]. The lower efficiency of an inverter can not only dramatically reduce the amount of power being provided, but also shorten the working hours of the battery. Therefore, because the battery system is a backup solution of the power source, and time of heating the pipe in amount of 3°C must within 6 minutes, we need to make sure that the battery can work at least 20 minutes.

The following calculations are made to calculate the efficiency of the inverter in the worst-case scenario:

1. Since the battery we found on Amazon.com is 12V DC with 7 Ah, the amount of power it gives to the inverter as an input power is:

$$E_{input} = IVt = 12 \times 7 \times 60 \times 60 = 302400J \quad \text{Eq.13}$$

2. Since the heating material we found needs 150 W, the amount of power it comes from the inverter as output power is:

$$E_{output} = IVt = 150 \times 20 \times 60 = 180000J \quad \text{Eq.14}$$

$$\eta = \frac{E_{output}}{E_{input}} = \frac{180000J}{302400J} = 59.52\% \quad \text{Eq.15}$$

As calculated above, the efficiency of the inverter to ensure the proper functioning of battery for at least 20 minutes is 59.53%. Since our inverter works better than the worst-case scenario, we can convince ourselves that our battery system well enough to sustain in the blackout period.

Another important thing is the AC/DC converter. As almost all the components on the PCB need the 3.3V DC power, the requirement, "output of AC/DC converter should be 3.3V±0.3V" is curial to our whole system. In the regulator design, we choose to use R_2 which equals to 770.8 Ω to meet the requirement. However, we cannot get the exact 770.8 Ω resistor in the real-life. To satisfy the minimum requirement, we also need to calculate the tolerance range of the resistor R_2 . As we know the formula of the voltage regulator (LM317L) [13]:

$$V_O = V_{REF} \left(1 + \frac{R_2}{R_1} \right) + I_{ADJ} R_2 \quad \text{Eq.16}$$

where $V_{REF} = 1.25V$, $I_{ADJ} = 50\mu F$ (which can be ignored), and $R_1 = 470\Omega$.

The first worst case is when the V_O is 3.0V:

$$\frac{3.0}{1.25} = 1 + \frac{R_2}{470}$$

$$R_2 = \frac{7}{5} \times 470 = 658\Omega$$

The second worst case is when the V_O is 3.6V:

$$\frac{3.6}{1.25} = 1 + \frac{R_2}{470}$$

$$R_2 = \frac{47}{25} \times 470 = 883.6\Omega$$

Thus, if our resistor within the range of 658 Ω to 883.6 Ω , our voltage regulator should work well.

3 Cost and Schedule

3.1 Cost Analysis

3.1.1 Parts

All the part we need and their costs are listed.

Table 4. Cost of Parts

Parts	Quantity	Manufacturer	Vendor	Price	Subtotal
1-1/2" x 5' Type L Copper Pipe	1	Menards	Menards	\$36.48	\$36.48
1-1/2" PVC Male Adapter	2	Carlson	Menards	\$1.54	\$1.54
Black pipe cap	2	Menards	Menards	\$1.76	\$1.76
DS18B20 Temperature Sensor	2	Maxim	Digi-Key	\$2.99	\$5.98
Z5357-ND DPDT Relay	1	OMRON	Digi-Key	\$11.81	\$11.81
MT2201-ND Transformer	1	Tamura	Digi-Key	\$5.08	\$5.08
LM317L Voltage Regulator	1	Texas Instrument	Mouser Electronics	\$0.62	\$0.62
DPCS10 Heating element	1	Briskheat	Gordo Sales	\$140.00	\$129.95
EXP1270 Rechargeable Lead Acid Battery	1	ExpertPower	Amazon	\$16.99	\$16.99
G5NB-E SPST POWER RELAY	2	Omron Electronics	Digi-Key	\$1.98	\$3.96
300W Inverter DC 12V to 110V AC	1	SNAN	Amazon	\$24.99	\$24.99
ATmega328P	1	Atmel	Microchip Technology	\$1.96	\$1.96
Adafruit HUZZAH ESP8266	1	Espressif	Adafruit	\$9.95	\$9.95
Total					\$251.07

3.1.2 Labor

Table 5. Labor Cost

Name	Hourly Rate	Hours	Total	Total×2.5
Qinru Li	\$25	300	\$7500	\$18750
Zichen Liang	\$25	300	\$7500	\$18750
Rui Lan	\$25	300	\$7500	\$18750
Total				\$56250

Grand total = Parts + Labor = \$251.07 + \$56250 = \$56501.07

3.2 Schedule

Table 6. Team Schedule

Week	Qinru Li	Zichen Liang	Rui Lan
2/20	Prepare for Design Review; Start setting up Arduino developing environment	Prepare for Design Review; start order all necessary equipment needed in project	Prepare for the Design Review; start to work on AC/DC Converter
2/27	Develop the communication with controller and temperature sensor	Start work on Heating System	Start to work on AC/DC Converter
3/6	Test the temperature sensor; start developing the Wi-Fi module; finish soldering assignment	Finish Heating System and start to work on Battery System; finish soldering assignment	Continue to work on AC/DC converter; finish soldering assignment
3/13	Test Wi-Fi module performance and start developing MQTT service	Finish Battery System	Finish the work on AC/DC Converter
3/20	Test the control of heating system; Help Zichen set up the water pipe	Start install heater on water pipe with all necessary safety isolations	Finish the first version of PCB
3/27	Finish all control system; Install the temperature sensors on the water pipe	Finish all installations	Start to work on Power Selection System
4/3	Test the whole control system; Finish MQTT service and develop PC software client	Test the cooperation between PCB and heating system	Finish the Power Selection System; start testing the PCB
4/10	Test the sensing system and control system	Test the heating system and battery system	Test the whole power system
4/17	Prepare for demo	Prepare for demo	Prepare for the demo
4/24	Start writing final paper of control and sensing system	Start writing final paper of heating system and battery system	Prepare the presentation of power system
5/1	Finish final paper on control and sensing system	Finish final paper on heating system and battery system	Finish the final paper on power system

4 Ethics and Safety

4.1 Ethics

As future electrical and computer engineers, we will obey and defend the IEEE Code of Ethics [16]:

#1 “to accept responsibility in making decisions consistent with the safety, health, and welfare of the public, and to disclose promptly factors that might endanger the public or the environment;”

We will make all decisions which are safe, health, and doing good to the public. The aim of our project is to help people solve problems rather than harm the public and society. In our project, we plan to use a lead acid battery rather than a lithium battery because of the safety reasons. We aim to provide users a safe product.

#3 “to be honest and realistic in stating claims or estimates based on available data;”

We will be practical and realistic to our project design and data acquire, avoiding overstate the function of our project or cheat on data we get. For example, we will be honest with the data from temperature sensors and use the real data to control our system.

#4 “to reject bribery in all its forms;”

We will report and record all the cost of each component of our project to prevent bribery in our design.

#5 “to improve the understanding of technology; its appropriate application, and potential consequences;”

We will treat this project as the integration of our undergraduate studies. We will apply what we learn during the four years to the project and do new research to explore and learn new technologies.

#9 “to avoid injuring others, their property, reputation, or employment by false or malicious action;”

We will obey the lab requirements and rules. We will do our research and design under the safety instruction. All the components we used should ensure the safety of our consumers. For example, we use the control system to prevent the whole system from over-heating.

#10 “to assist colleagues and co-workers in their professional development and to support them in following this code of ethics.”

We will help and support each other to finished the project. We will supervise each other to obey the IEEE Code of Ethics.

4.2 Safety

Our project will use wall outlet power as the power supply, which’s voltage is 110V-120V AC. Using this power safely is crucial in our whole design. During our design, we will consider the following rules:

- Disconnect the power supply when connecting or debugging the circuit;
- Prior testing the circuit, double check the connection by another group member;
- Using the circuit component which designed for high-voltage situation;
- Don’t place the circuit in heat or humid situation, keep it cool and dry;
- Using simulation software to test before doing the bench test;
- Follow the datasheet of all components, prevent improper power usage.

Since we use a battery as a backup system of wall outlet power supply. The rated voltage is 12V DC. While this is not very high voltage, we must use this external battery with care. During our design, we will also follow these rules:

- Carefully distinguish the polarities of battery to avoid of sparks happening;
- Do not overuse the rated voltage.
- Store the battery in a cool and dry place

The battery system also contains a DC to AC inverter which provides us 110V AC voltage. When we test the inverter, we should apply all the rules before for the high-voltage power supply and for the battery system.

To ensure the safety, we plan to manual control the two power sources when testing on them. For the battery, we can use the switch on the battery to control it. For the power coming from a wall outlet, we plan to add another SPST relay before it goes into the power selection system. The coil of the relay will connect to 5V DC voltage provided in the lab. Thus, we can manually active or close the power source by using this relay, which ensures the safety.

Also, our project has a heating system which design to heat up the copper water pipe. The heating system needs to be used carefully as well. During our design, we will also follow these rules:

- Disconnect the power of the heating system unless testing;
- Avoid touch the heating pipe directly by hands;
- Leave the heating system in cool and dry condition;
- Avoid expose the heating tube to water or other humid conditions;
- Design the feedback control prevent the heating tube from overheat.

As we are going to dealing with both the electricity and water, we need to do the waterproof insulation on the heating element to avoid the dangerous condition when the heating element contact with water. Also, to protect the functionary of the sensors, which will be installed on the copper pipe, we plan to add both thermal insulation and water-proof insulation to them.

Besides, all the team members must finish and pass the lab safety training before working in the senior design lab. We should also keep in the mind the instruction all the time when we are working in the lab.

5 Reference

- [1] Amazon. "9ft. DURABLE GardenHOME Cold Weather Pipe and Valve HEATING CABLE warmer with BUILT IN Thermostat, keeps your pipes ICE FREE and avoids freezing pipes, De Icing Kit ist flexible and EASY to install", 2017. [Online]. Available: https://www.amazon.com/DURABLE-GardenHOME-Thermostat-freezing-flexible/dp/B015JXDPAO/ref=sr_1_2?ie=UTF8&qid=1487956243&sr=8-2&keywords=heating+cable
- [2] Maxim. "Programmable Resolution 1-Wire Digital Thermometer", 2016. [Online]. Available: <https://cdn-shop.adafruit.com/datasheets/DS18B20.pdf>
- [3] Atmel. "ATMEL 8-BIT MICROCONTROLLER WITH 4/8/16/32 KBYTES IN-SYSTEM PROGRAMMABLE FLASH", 2015. [Online]. Available: http://www.atmel.com/images/Atmel-8271-8-bit-AVR-Microcontroller-ATmega48A-48PA-88A-88PA-168A-168PA-328-328P_datasheet_Complete.pdf
- [4] adafruit.com. "Adafruit HUZZAH ESP8266 breakout", 2016. [Online]. Available: <http://www.mouser.com/ds/2/737/adafruit-huzzah-esp8266-breakout-932845.pdf>
- [5] gordosales.com. "5 gallon plastic bucket heater- DPCS10", 2017. [Online]. Available: <http://www.gordosales.com/store/pc/5-gallon-plastic-bucket-heater-DPCS10-p3707.htm>
- [6] Digi-Key. "Omron Electronics Inc-EMC Div G5NB-1A-E DC5", 2017. [Online]. Available: <http://www.digikey.com/product-detail/en/omron-electronics-inc-emc-div/G5NB-1A-E-DC5/Z2771-ND/1731471>
- [7] Amazon.com. "ExpertPower 12V 7 Amp EXP1270 Rechargeable Lead Acid Battery", 2017. [Online]. Available: https://www.amazon.com/ExpertPower-EXP1270-Rechargeable-Lead-Battery/dp/B003S1RQ2S/ref=sr_1_1?ie=UTF8&qid=1487726717&sr=8-1&keywords=12vdc+battery
- [8] Amazon.com. "SNAN 300W Car Power Inverter DC 12V to AC 110V with Dual AC Outlet and 4.8A Dual USB Charging Port", 2017. [Online]. Available: <https://www.amazon.com/dp/B019IFYMQU?psc=1>
- [9] DataSheetCafe. "DPDT Relay – Double Pole Double Throw Relay", 2015. [Online]. Available: <http://www.datasheetcafe.com/dpdt-relay-double-pole-double-throw-relay/>
- [10] Digi-Key. "Omron Electronics Inc-EMC Div G2R-2-AC110", 2017. [Online]. Available: <http://www.digikey.com/products/en?keywords=Z5357-ND%20>
- [11] Omron.com. "The Best Seller G2R", n.d. [Online]. Available: <http://www.omron.com/ecb/products/pdf/en-g2r.pdf>

- [12] Digi-Key.com. "3FS-2XX series", 2009. [Online]. Available: <http://www.digikey.com/product-detail/en/tamura/3FD-424/MT2115-ND/98323>
- [13] Texas Instrument. "LM317L 3-Terminal Adjustable Regulator", 2014. [Online]. Available: <http://www.ti.com/lit/ds/symlink/lm317l.pdf>
- [14] menards.com. "1-1/2" x 5' Type L Copper Pipe", n.d. [Online]. Available: <https://www.menards.com/main/plumbing/rough-plumbing/pipe-tubing-hoses-fittings-accessories/copper-pipe-tubing/copper-pipe/p-1483428094287-c-8565.htm?tid=4791873874477026403>
- [15] solar-facts.com. "How Much of your DC Power Comes Out as AC Power", 2016. [Online]. Available: <http://www.solar-facts.com/inverters/inverter-efficiency.php>
- [16] IEEE.org. "IEEE Code of Ethics", 2016. [Online]. Available: <http://www.ieee.org/about/corporate/governance/p7-8.html>
- [17] calctown.com. "small signal analysis of CD MOSFET Amplifier", n.d. [Online]. Available: <http://www.calctown.com/calculators/small-signal-analysis-common-drain-mosfet-amplifier>