

Phys 102 – Lecture 23

Diffraction

Today we will...

- Learn about diffraction – bending of light by objects
 - Single slit interference
 - Circular aperture interference
- Apply these concepts
 - Resolution of optical instruments
 - X-ray crystallography

Single slit interference?

What happens when light passes through a small slit?

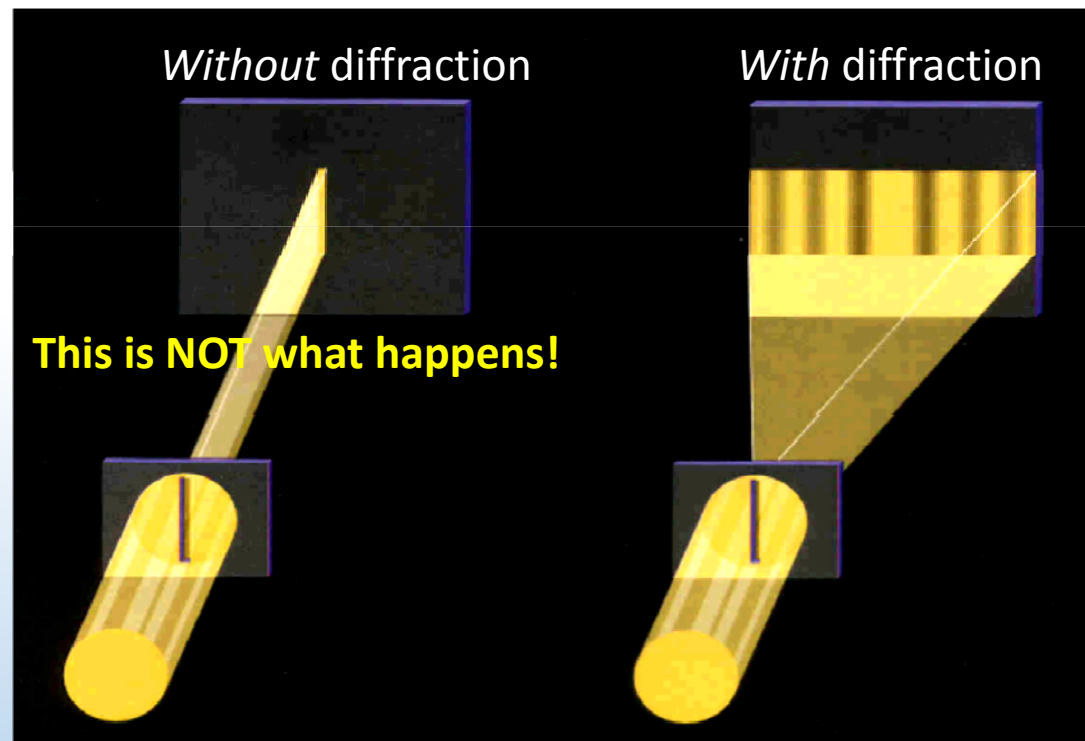

Diffraction – the apparent bending of light around an object or aperture

Diffraction & Huygens' principle

Coherent, monochromatic light passes through one narrow slit

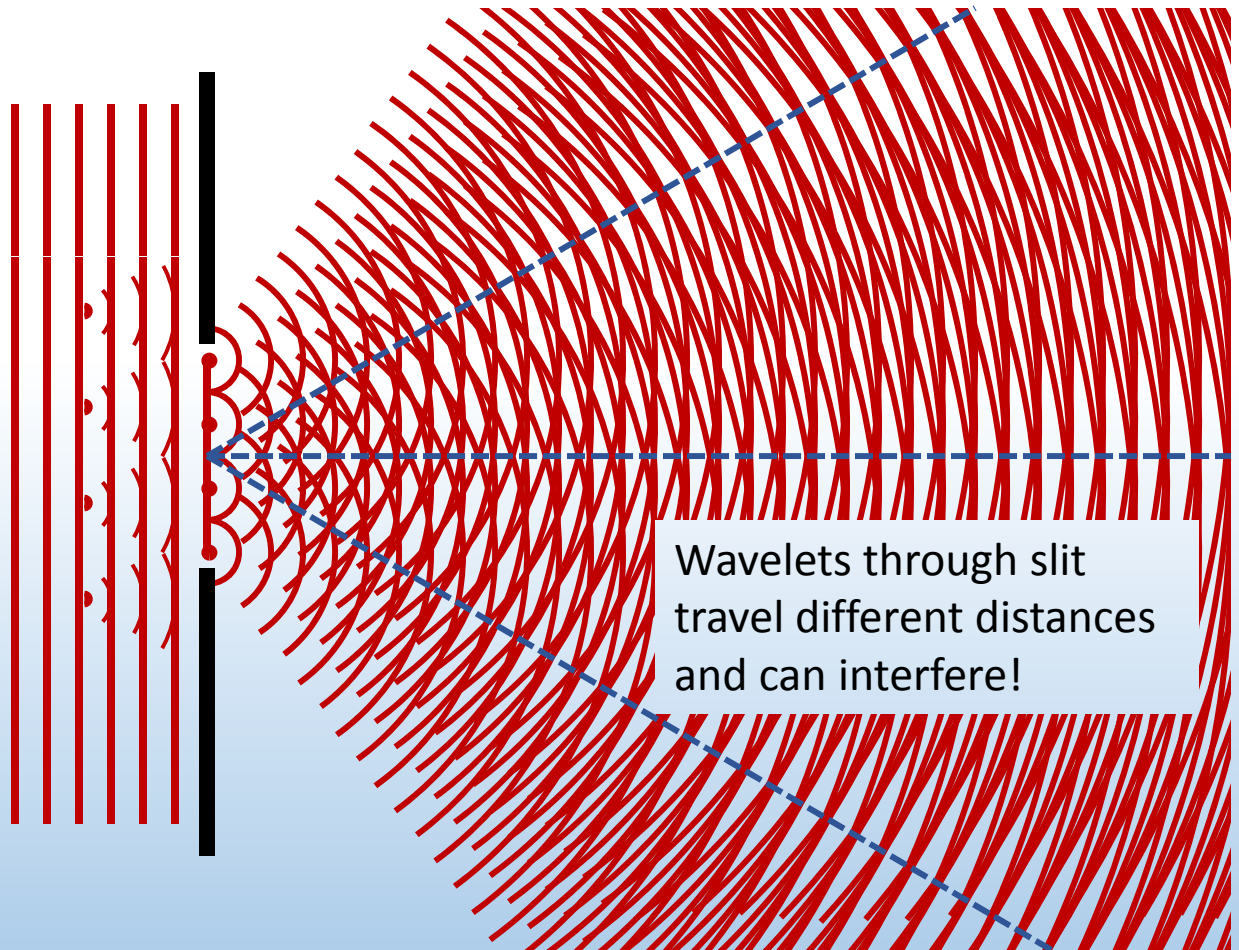

Where are the interference maxima and minima?

Single slit diffraction

Consider waves from top and bottom $\frac{1}{2}$ of slit of width a

At this angle, every wave from top $\frac{1}{2}$ of slit interferes destructively with corresponding wave from bottom $\frac{1}{2}$

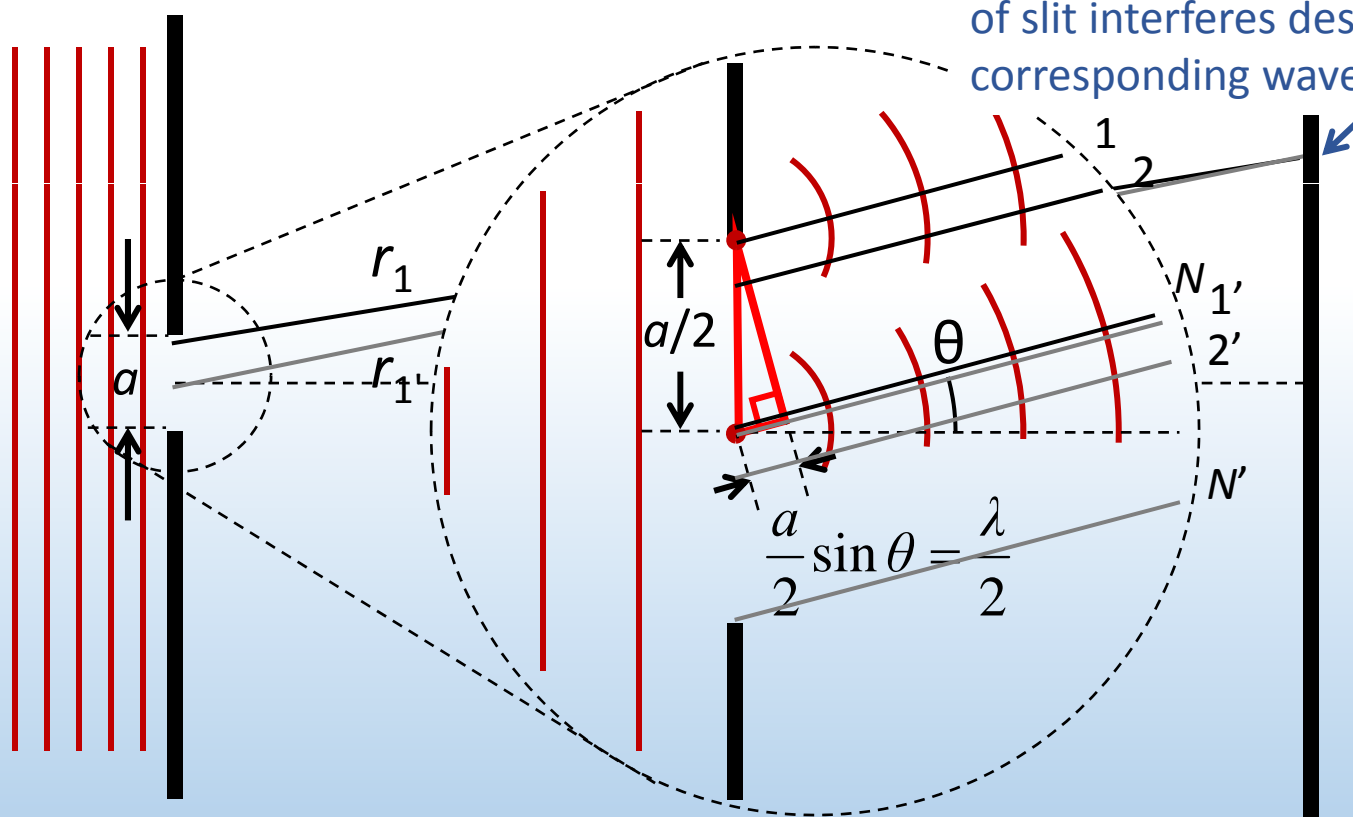

Destructive: $r_1' - r_1 = r_2' - r_2 = \dots = r_{N'} - r_N = a \sin \theta_1 = \lambda$

1st minimum

Single slit diffraction

Consider waves from $\frac{1}{4}$'s of slit

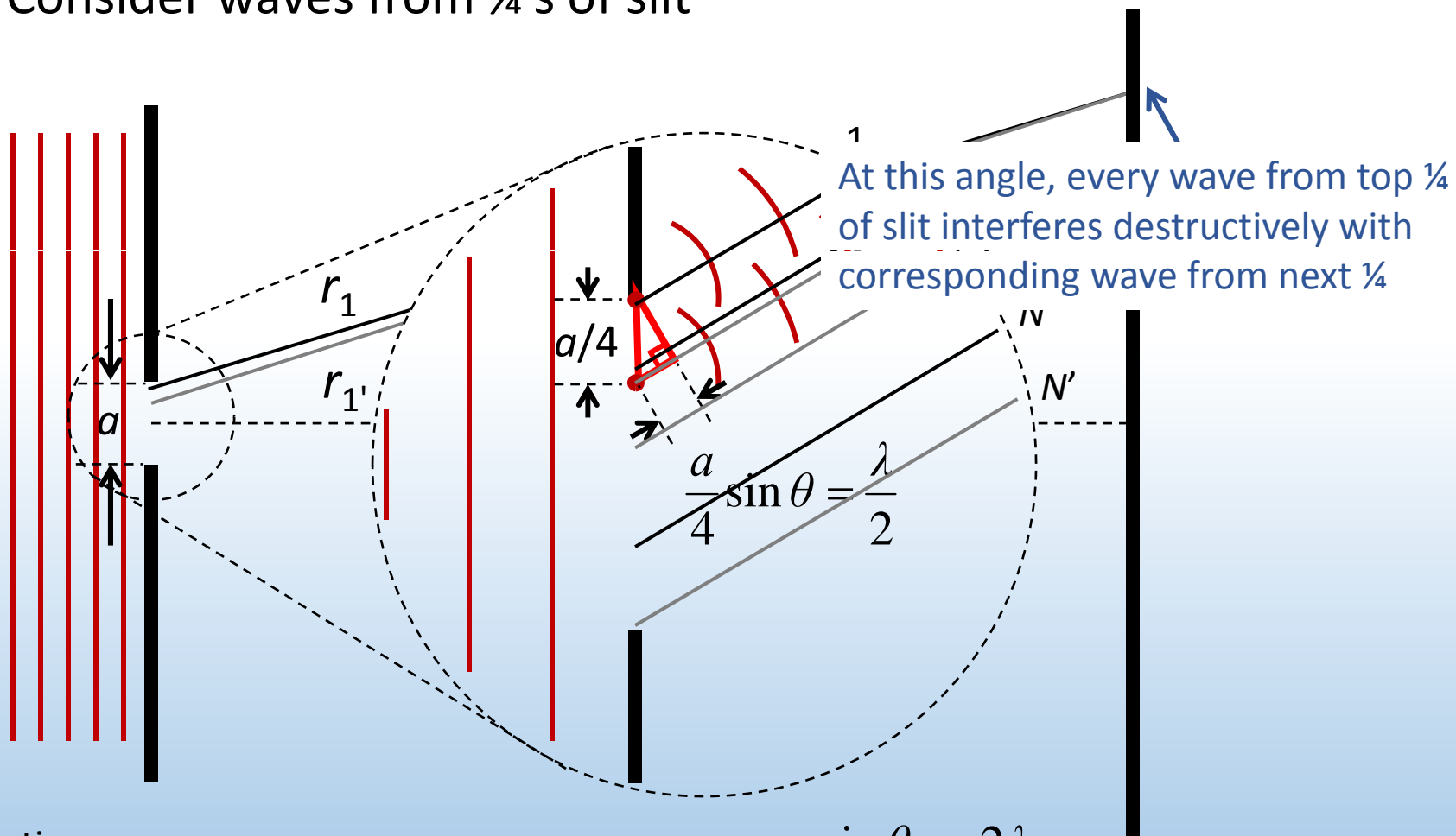

Destructive: $r_1 - r_1 = r_2 - r_2 = \dots = r_{N'} - r_{N'} = a \sin \theta_2 = 2\lambda$

2nd minimum

Single slit diffraction minima

Condition for **sixths** of slit to interfere destructively

$$a \sin \theta_3 = 3\lambda$$

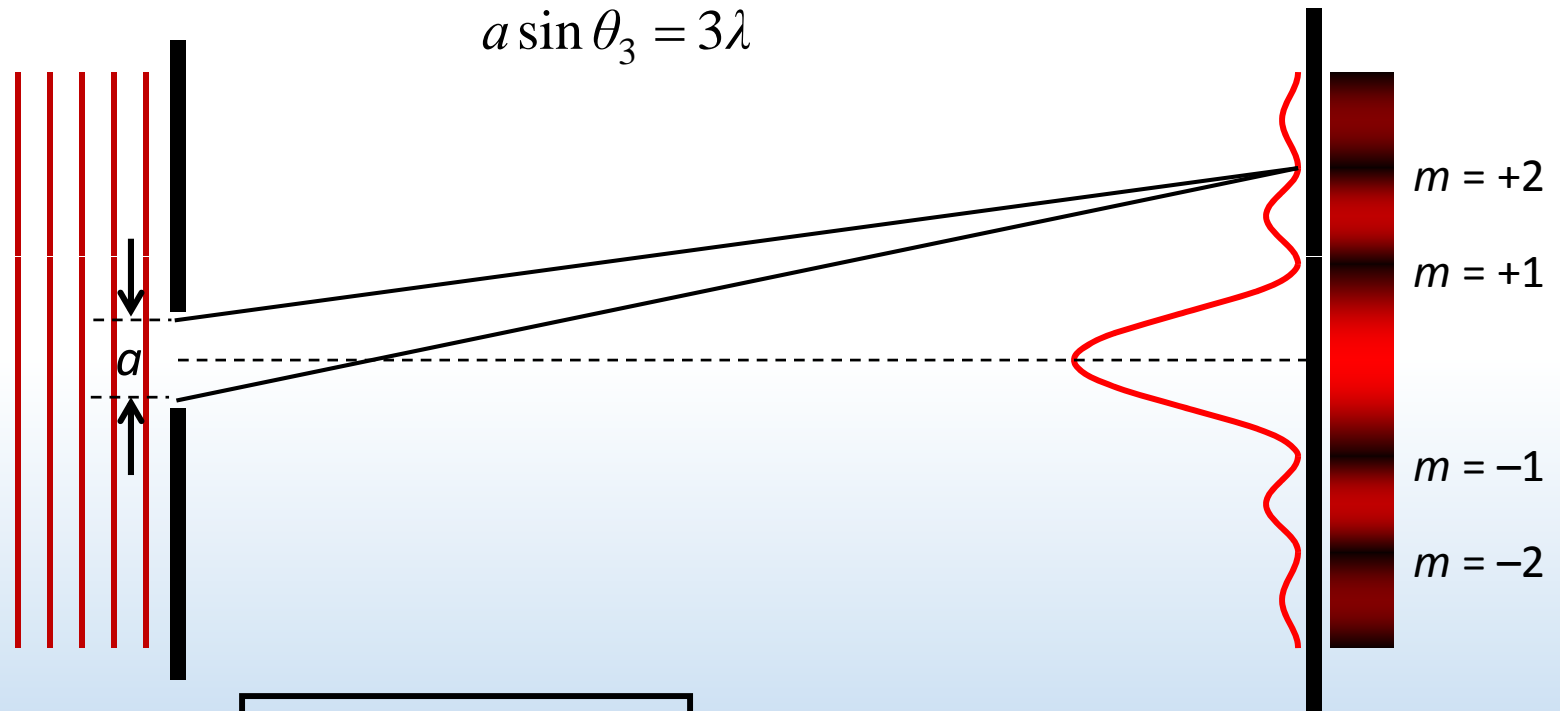

In general,

$$a \sin \theta_m = m\lambda$$

$$m = \pm 1, \pm 2, \dots$$

THIS FORMULA LOCATES MINIMA!!

Note the maximum at $m = 0$, why?



ACT: CheckPoint 1

The width a of the slit in the screen is decreased

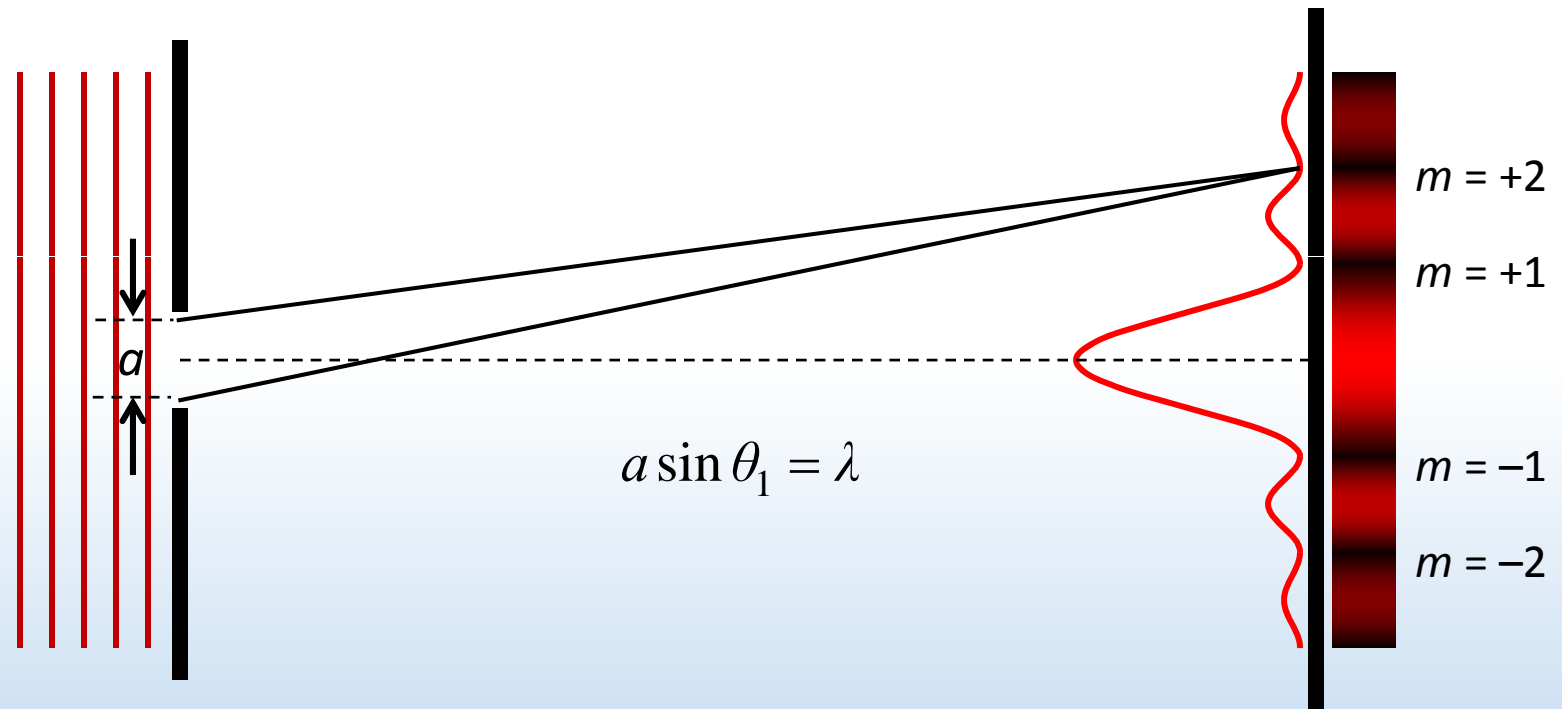

What happens to the light pattern on the screen?

- A. It gets wider B. Stays the same C. It gets narrower



ACT: Wide double slits

Consider a double slit where the slit width a is not negligible. The separation d between slits is such that $d = 3a$.

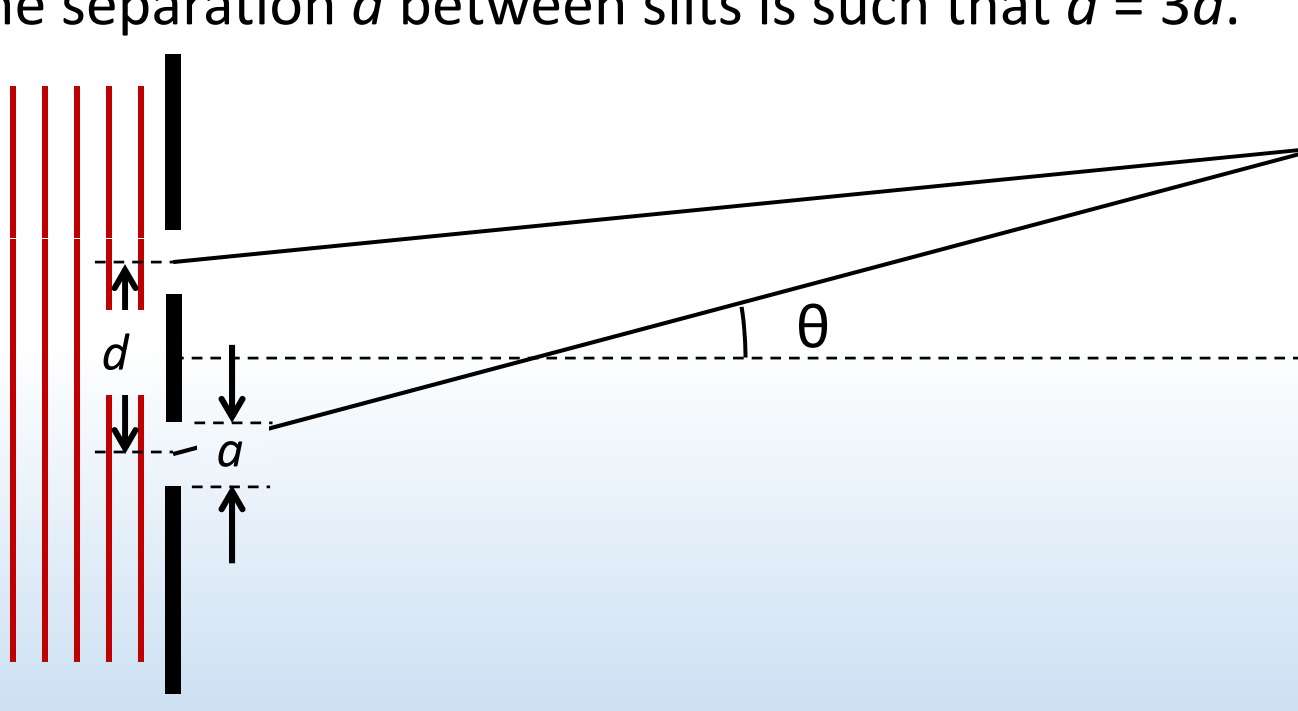

At an angle θ where $d \sin \theta = 3\lambda$, what do you see on the screen?

A. A maximum

B. A minimum

C. In between

Diffraction in 2D

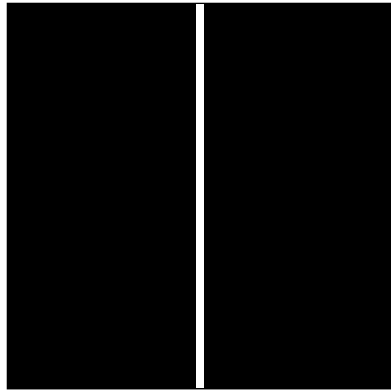

Single slit

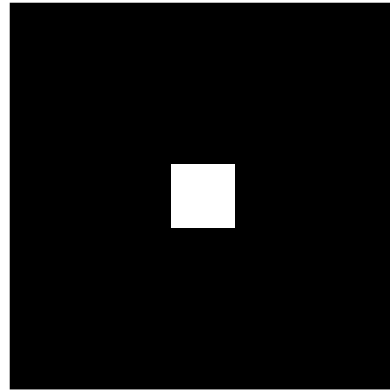
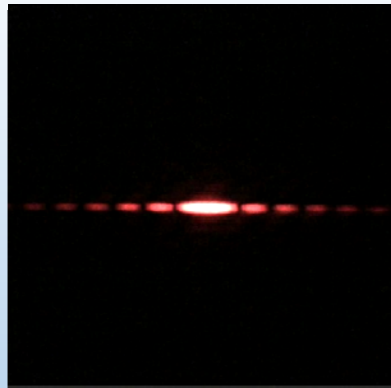

Square aperture

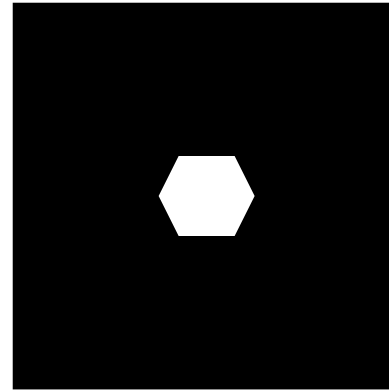
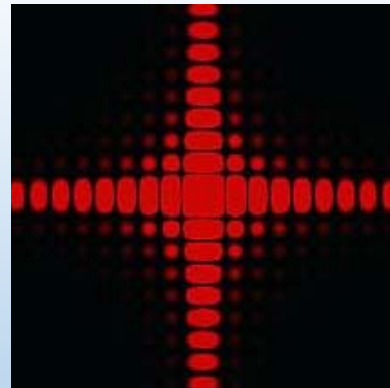

Hexagonal aperture

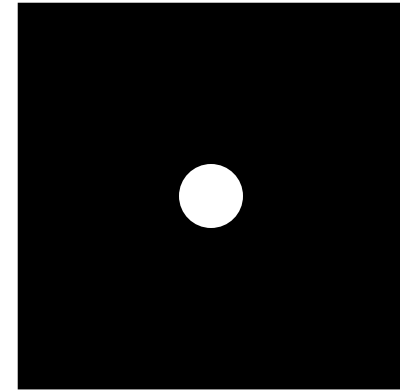
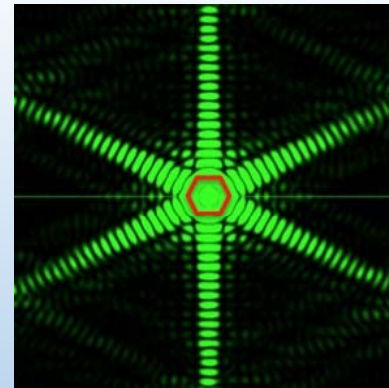

Circular aperture

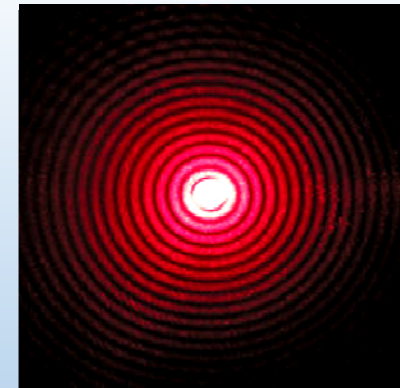

CheckPoint 2

Diffraction from circular aperture

1st diffraction minimum

Central maximum

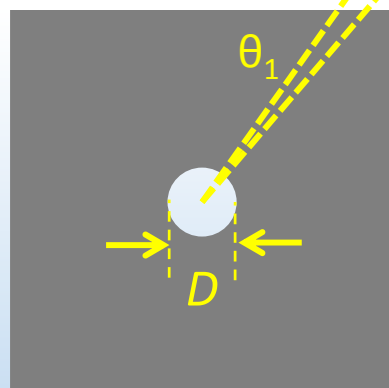
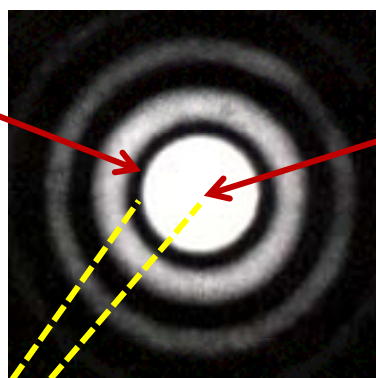

$$D \sin \theta_1 = 1.22 \lambda$$

Maxima and minima will be a series of bright and dark rings on screen

Resolving power

Light through aperture (of eye, camera, microscope, telescope, etc.) creates diffraction pattern

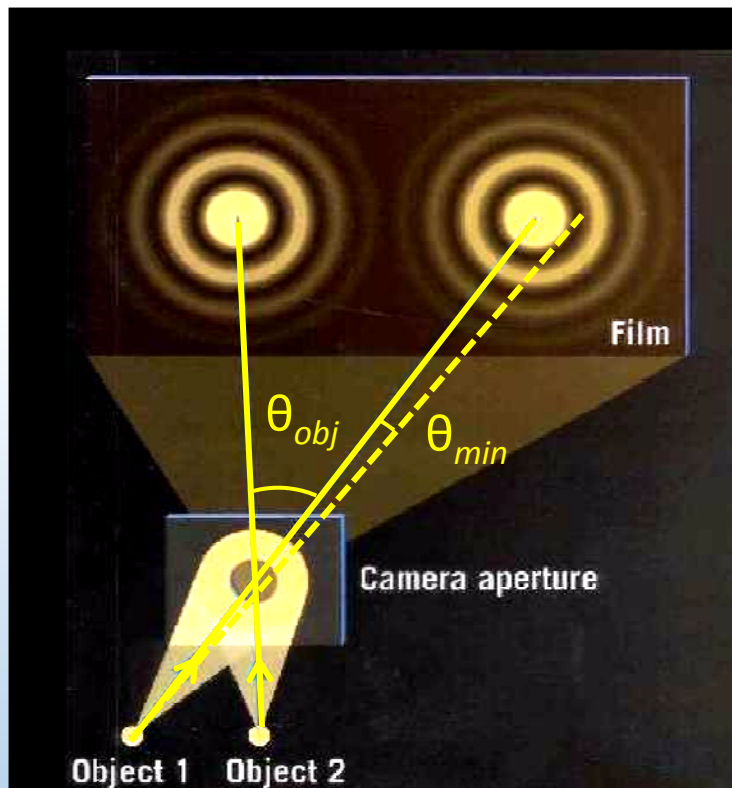

Two objects are resolved only when:

$$\theta_{obj} \geq \theta_{min} \quad \text{"Diffraction limit"}$$

Larger spacing

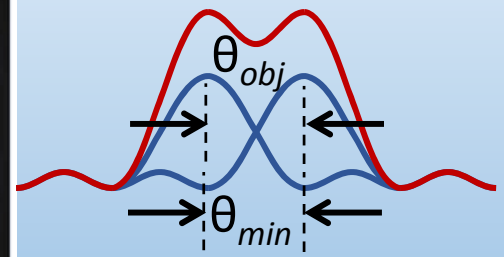
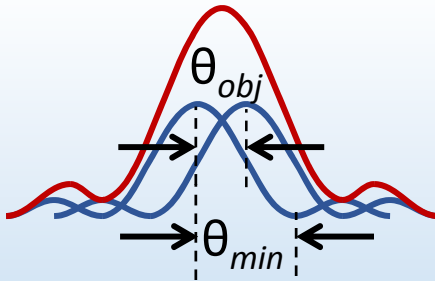
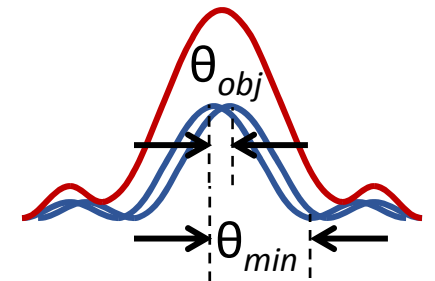
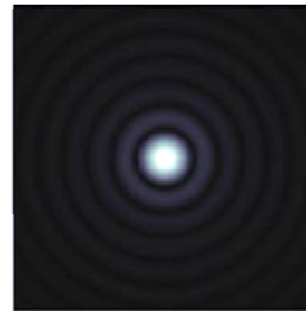

Calculation: microscope resolution

A microscope objective has an aperture size $D = 6.8$ mm, and a focal length $f = 4$ mm. What is the closest distance two green light sources ($\lambda = 530$ nm) can be to resolve them?

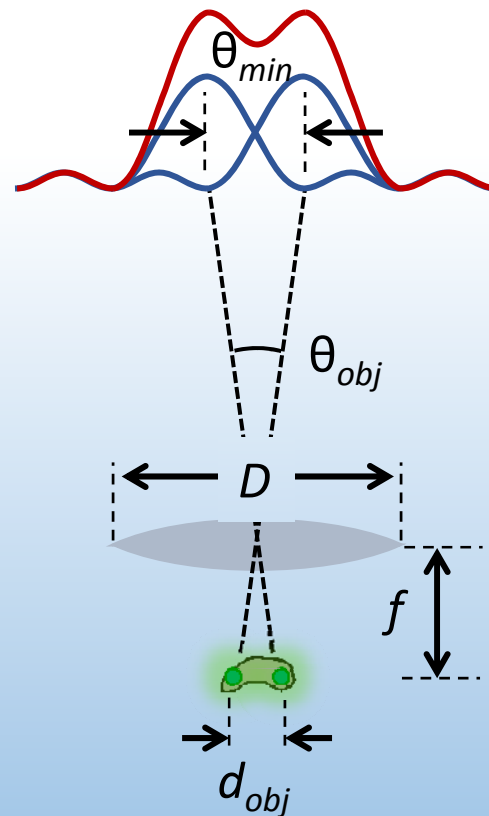

Use small angle approximation:

$$\theta_{min} \approx 1.22 \frac{\lambda}{D} \quad \theta_{obj} \approx \frac{d_{obj}}{f}$$

Want: $\theta_{obj} \geq \theta_{min}$

$$d_{obj} \geq 1.22 \frac{\lambda f}{D} \approx 1.22 \lambda \left(\frac{4 \text{ mm}}{6.8 \text{ mm}} \right) \approx 0.7 \lambda$$
$$\geq 380 \text{ nm}$$

Ultimate limit to resolution: $d_{obj} \approx 0.5 \lambda$



ACT: CheckPoint 3

You are on a distant planet with binary suns. You decide to view them by building a pinhole camera. Light from both suns shines through the hole, but you can only see one spot on a screen.



You should make the pinhole _____

A. Larger

B. Smaller



ACT: Rectangular slit

A goat has a rectangular shaped pupil, with the long axis along the horizontal.



In principle, in which direction should a goat's eye have higher resolution?

A. Horizontal

B. Vertical

Diffraction from a crystal

EM waves of short wavelength scatters off of atoms

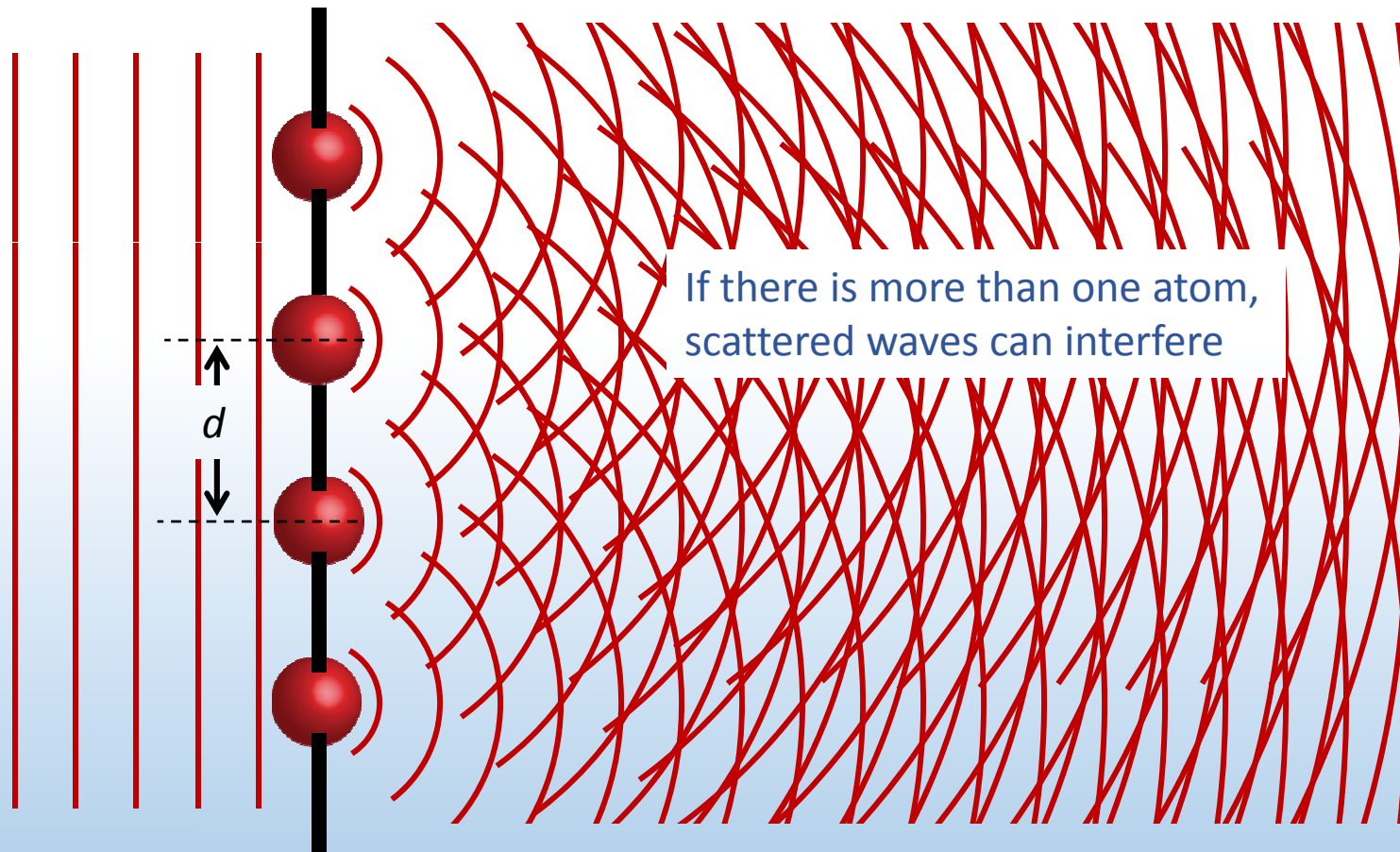

Crystals – periodic arrangements of atoms – create same interference pattern as diffraction grating!



ACT: Crystal diffraction

In a NaCl crystal, the spacing between atoms is 0.282 nm. Which of the following wavelengths could be used to see a clear diffraction pattern?

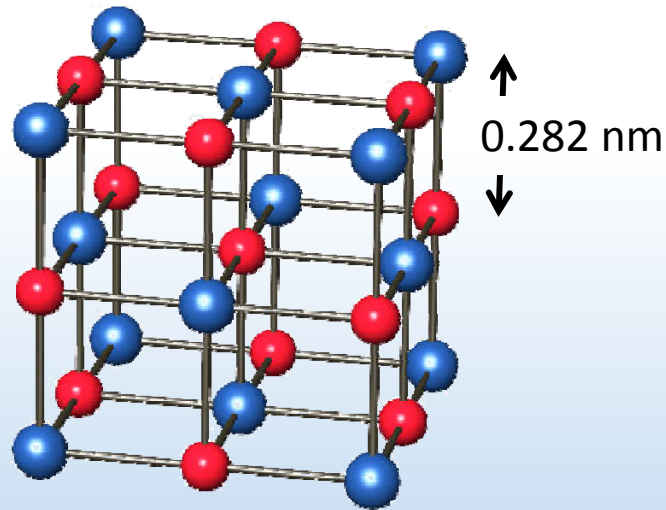

A. $\lambda = 0.1 \text{ nm}$

B. $\lambda = 1 \text{ nm}$

C. $\lambda = 10 \text{ nm}$

X-ray crystallography

Given X-ray wavelength λ , diffraction angles θ provide information about distance d between atoms in crystal

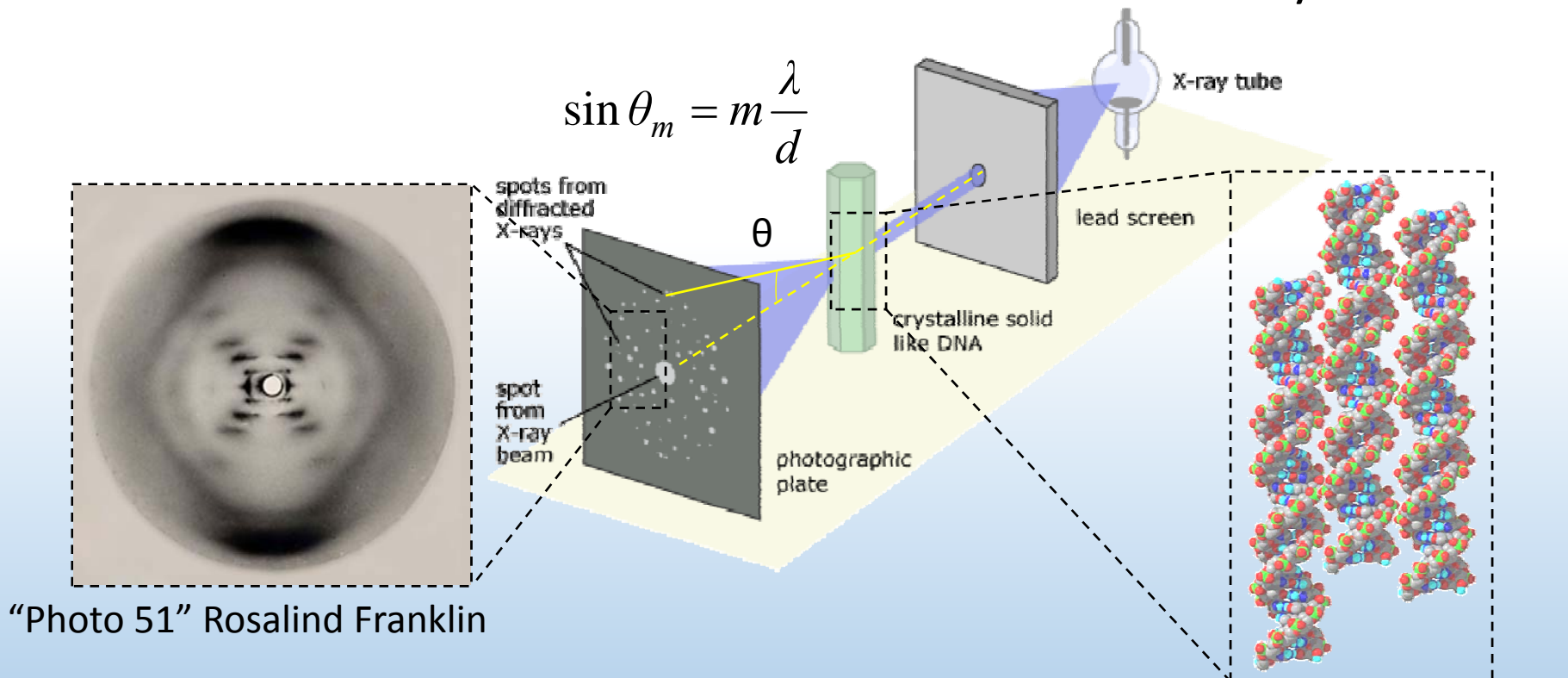

“Photo 51” Rosalind Franklin

Crystalline fiber of DNA

As long as $\lambda < d$, small features lead to large θ . BUT need regular ordering of atoms – i.e. a crystal!

Diffraction pattern of DNA

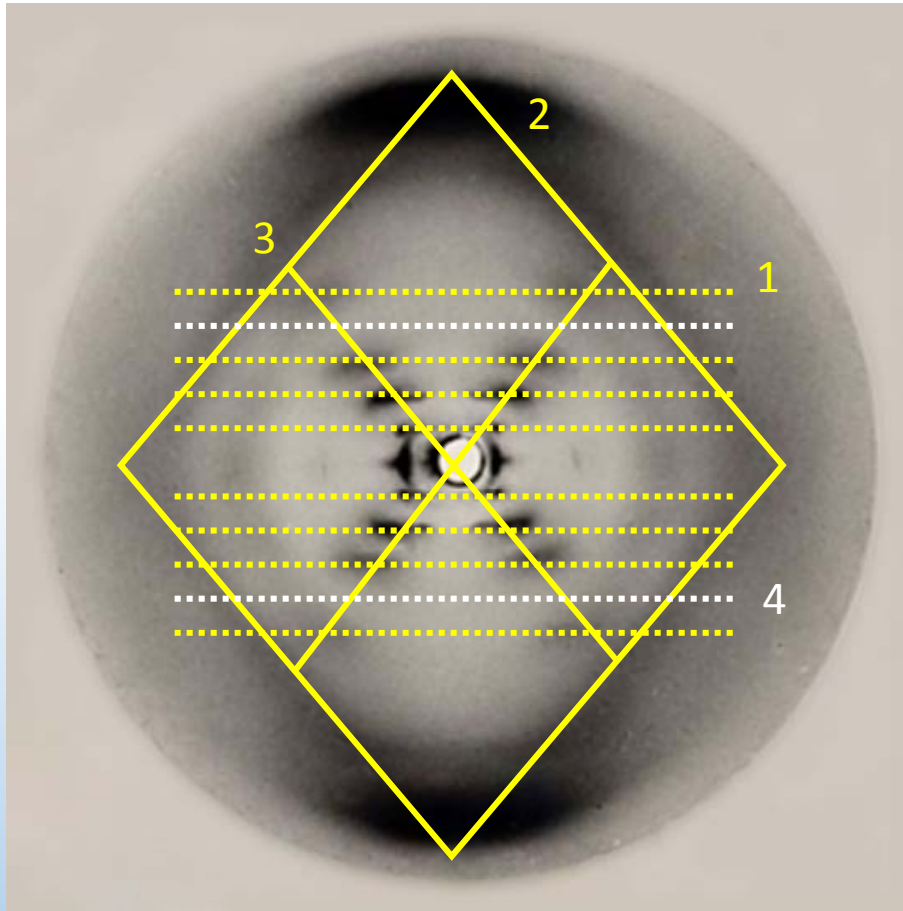

Features of pattern:

- 1) Layer lines
- 2) Outer diamond
- 3) Cross pattern
- 4) Missing 4th layer line

“Photograph 51” – Rosalind Franklin

Layer lines & diamond pattern

What features in DNA generate layer lines and diamond pattern?

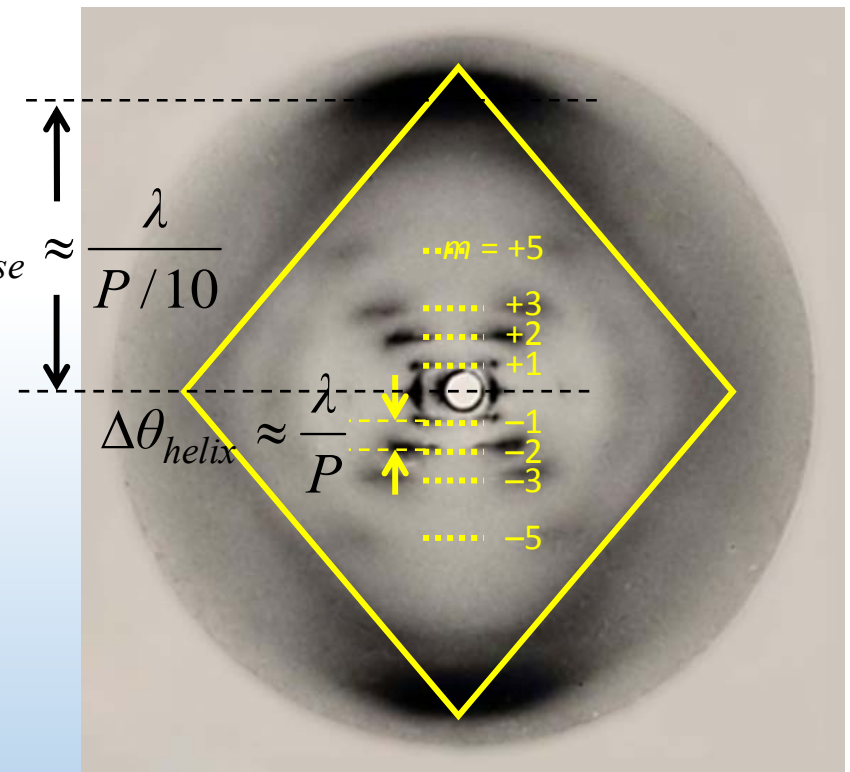
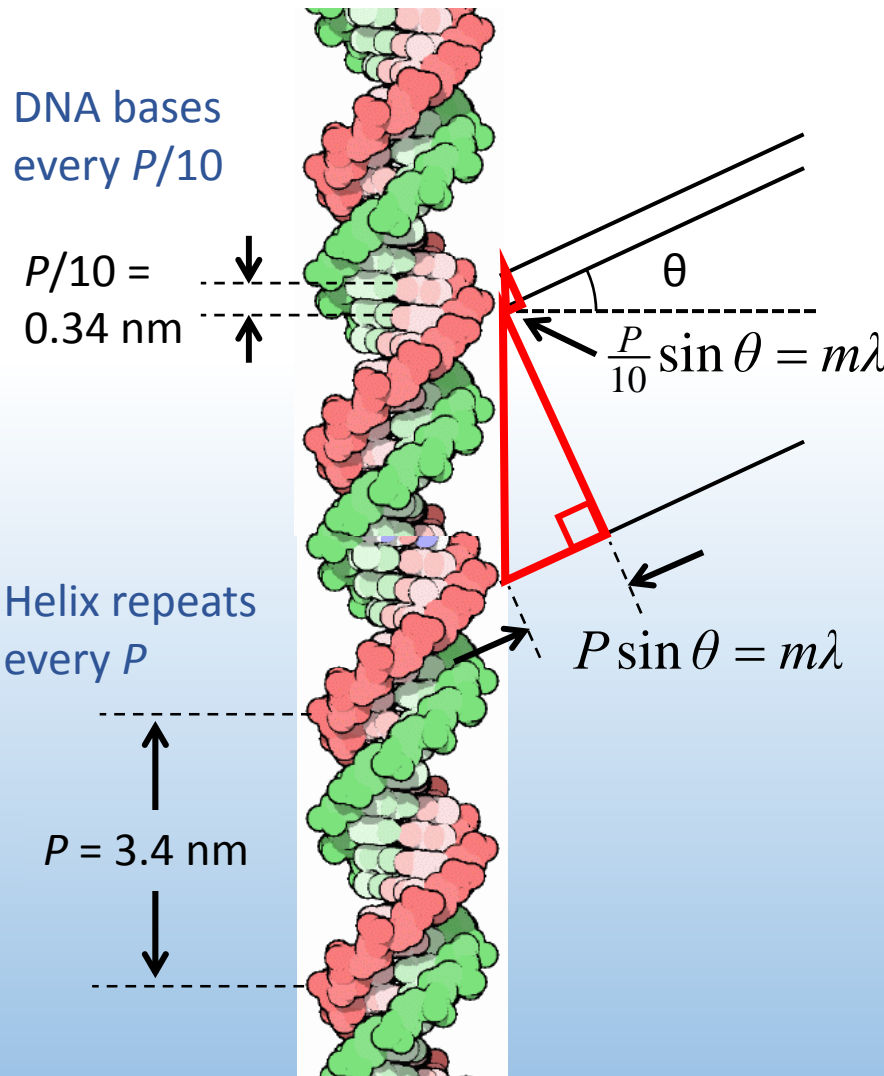

Note that large (small) distances diffract to small (large) angles

Cross pattern

Why does DNA diffraction generate cross pattern?

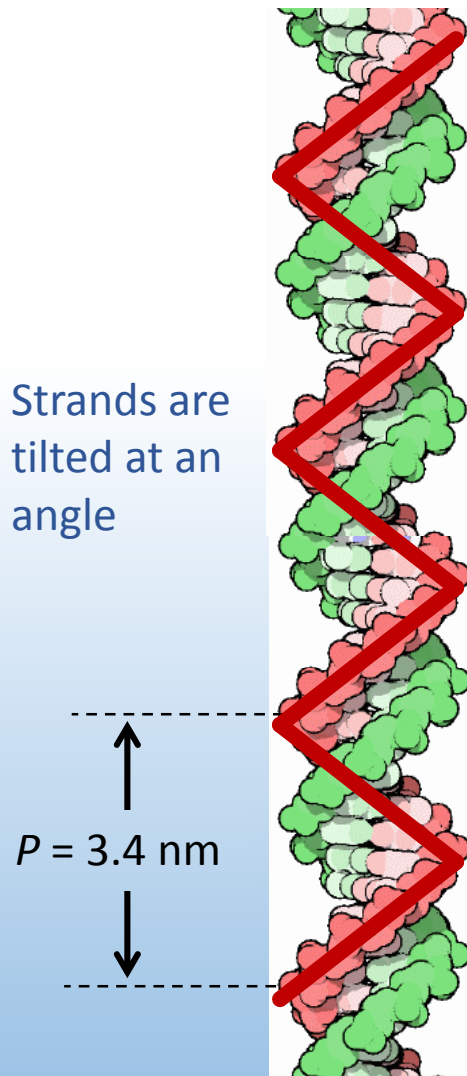

Slit pattern

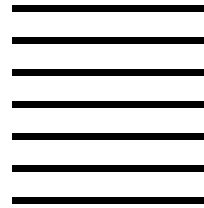

Interference pattern



Light diffracted \perp to slit

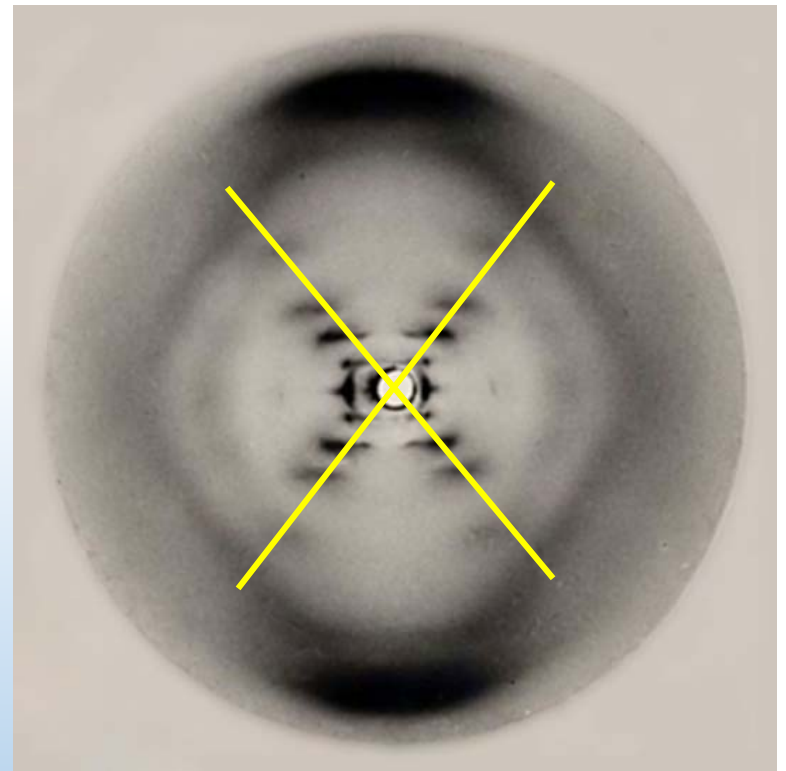

Key to discovery of helix structure



ACT: DNA cross pattern

You discover a new structure of DNA in which the diffraction pattern is the same as the “normal” DNA in every respect EXCEPT that the cross makes a more acute angle α

“Normal” DNA

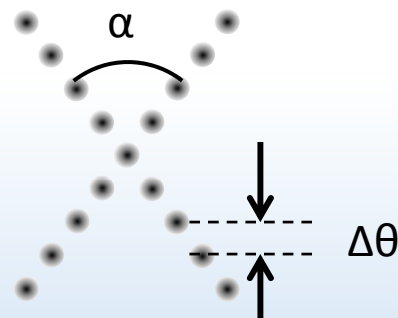

New form of DNA

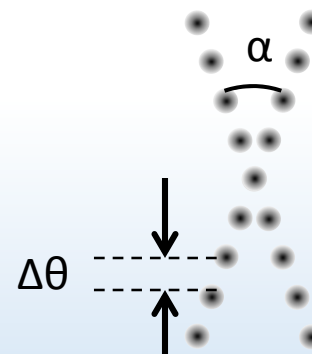

Which statement regarding the new DNA structure must be true?

- A. It cannot be a helix
- B. The helix repeat distance P must be different
- C. The helix tilt angle must be different

Missing 4th layer

Why is there no interference maximum at $m = 4$?

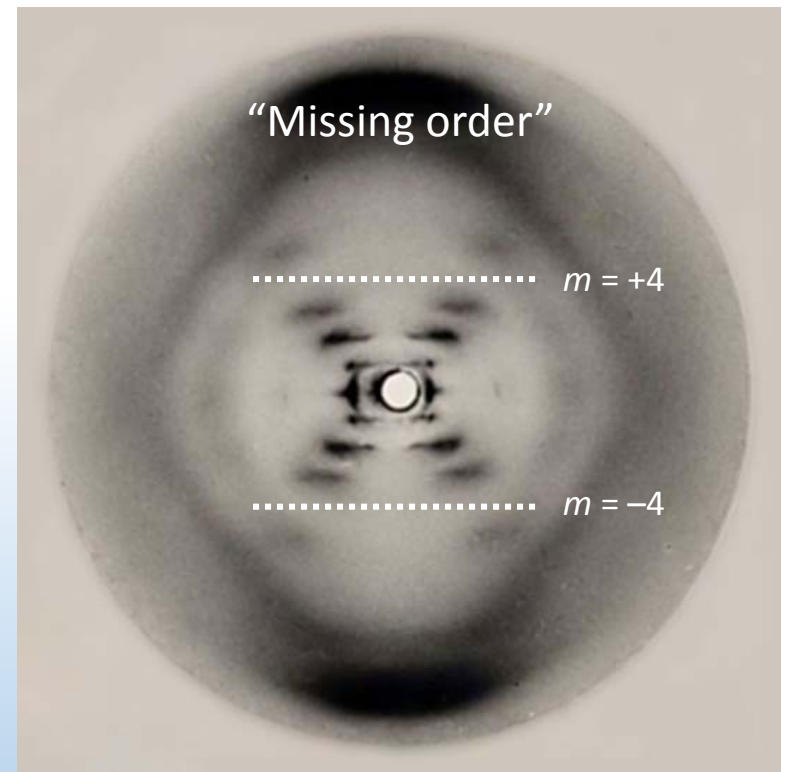
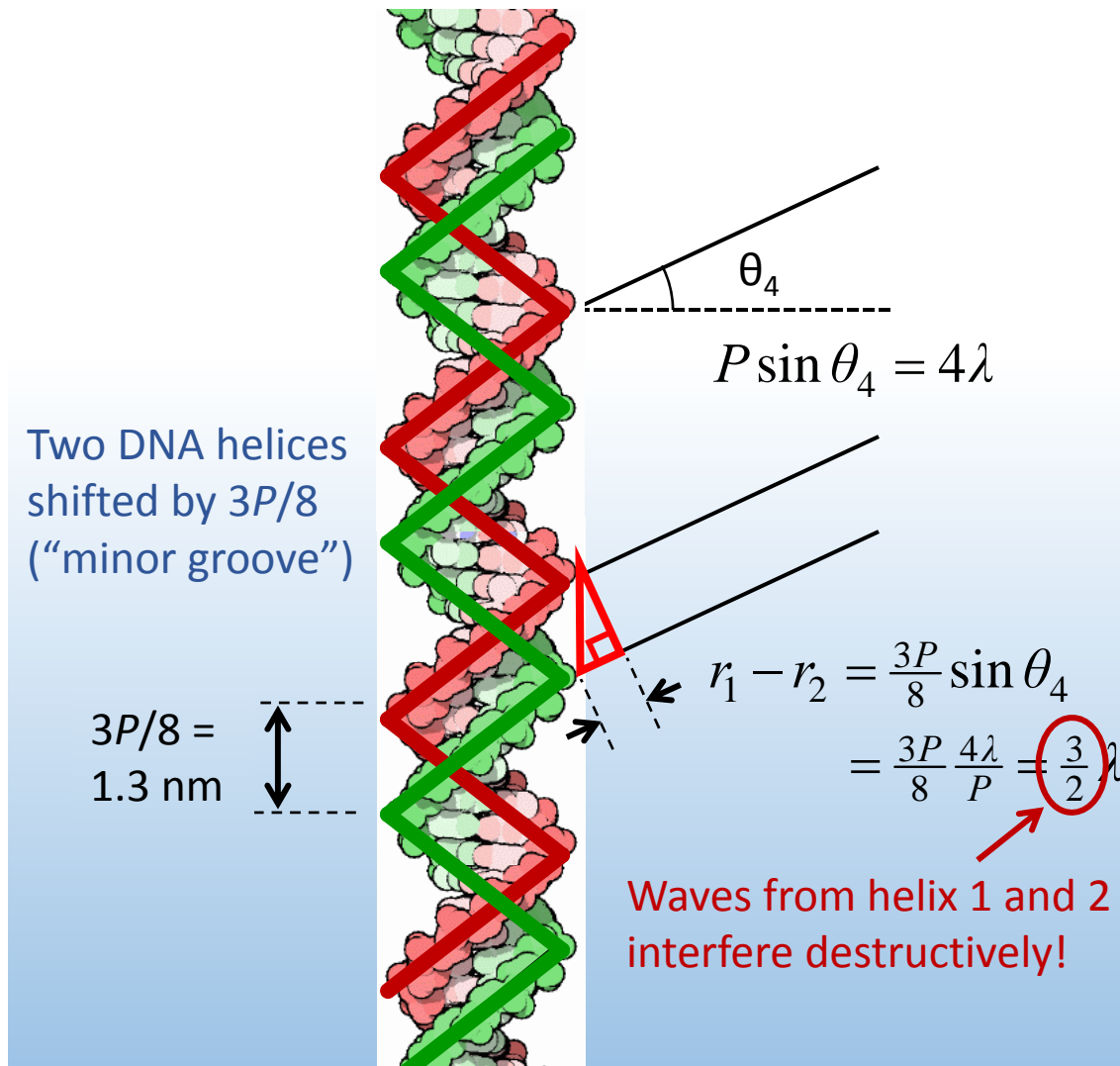

Key to discovery of *double helix*

Summary of today's lecture

- Single-slit diffraction

Interference minima: $a \sin \theta_m = m\lambda$ $m = \pm 1, \pm 2, \dots$

- Circular aperture diffraction

First interference minimum: $D \sin \theta_1 = 1.22\lambda$

- Resolution in optical instruments

Angle subtended by objects \geq angle of first diffraction minimum

- X-ray diffraction

Small distances \rightarrow large diffraction angles