

Welcome to Physics 102!

- Electricity + Magnetism

(at the heart of most processes around us:
...in atoms & molecules; living cells)

- Optics

- Atomic Physics

- Nuclear Physics

- Relativity

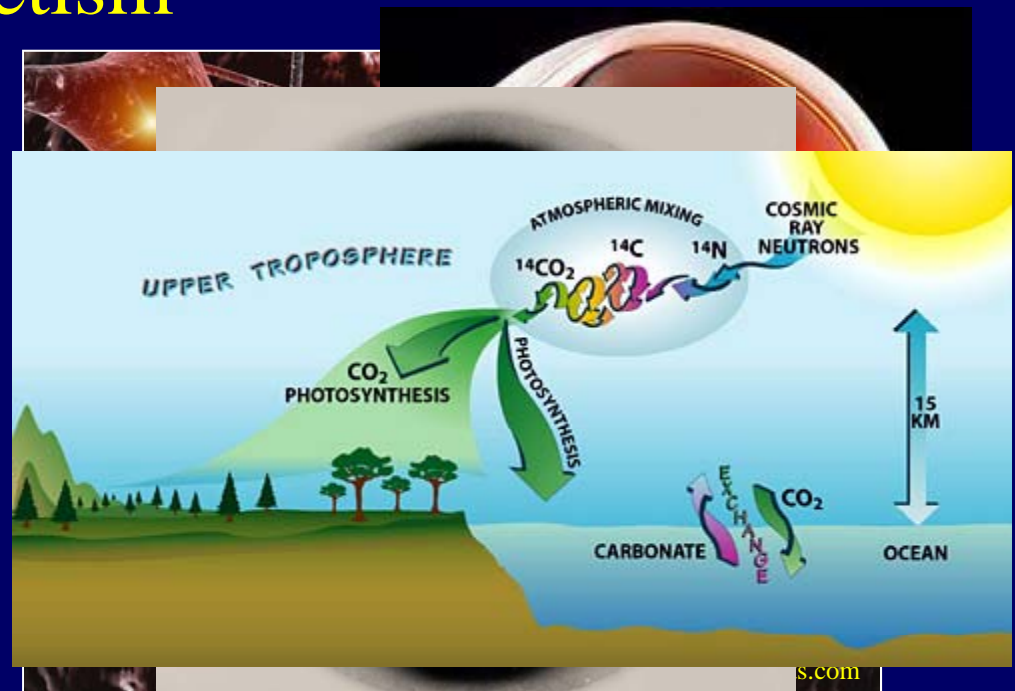

Please turn cell phones off

Meet the Lecturer

- Yann Chemla

ychemla@illinois.edu

- Research:

Biophysics

- see <http://www.illinois.edu/~ychemla>

- Office Hours: Monday 3-4pm, Loomis 161



When emailing me:

- Email must be sent from @illinois.edu
- Subject line should begin with “PHYS102 question:”
- Message should contain:
 - your full name, netID, discussion section, TA name
- Questions about physics:
 - Do not use email, use office hours (see course website)
- Before emailing:
 - Verify information is not already on the course website
 - The course directors reserve the right to penalize your HW score if you ask questions via email that are answered on the website

Course Website

- <http://courses.physics.illinois.edu/phys102/>
- **Syllabus**
 - what you should be doing and when you should be doing it
 - Lectures posted after they are given
- **Course Description / Excused Absences**
- **Required Materials**
 - Be sure to register your i-Clicker prior to lecture
- **First Discussion: 1/15**
- **First Lab: 1/23**
- **Exam dates: 2/18, 3/11, 4/15 at 7 pm**

Course Philosophy

- Read about it (textbook) ^{+ Check pts.}
- Untangle it (lectures)
- Play with it (labs)
- Challenge yourself (homework)
- Close the loop (discussion/quiz)

The order is important!

Grading

• CheckPoints & Lectures	50
• Homework	150
• Lab (Prelab due at start of lab)	150
• Discussion	100
– in-class quizzes; drop lowest 1	
• Hour Exams (3 x 100)	300
• Final Exam	<u>250</u>
	1000

Physics Department letter grades:

A+(950), A(920), A-(900), B+(880), B(860), B-(835), C+(810),
C(780), C-(750), D+(720), D(690), D-(610), and F(<610).

This is a challenging course!

Usually mean & median=B-, 20% of students get C or lower

CheckPoints & ACTS

- Answer CheckPoints 50/1000 points

smartPhysics

- 1 point for attempt at Checkpoint.

- ACTS: use iClicker in class

- 1 point for answering the questions



- 2 points/lecture x 25 lectures = 50 points
- Note that there are 28 lectures, so you have some free ones

Register i-Clicker before lecture: [gradebook](#)



ACT: iClicker test

Change your frequency to BB at the beginning of every lecture

- Let's take a poll. What is your major?
 - A) pre-med
 - B) biology (MCB or IB), non pre-med
 - C) other
 - D) undecided

iClicker registration problems? Check registration in the Gradebook first.

Prerequisite!

Content

Physics 101

Macroscopic

- Kinematics
- Forces
- Energy
- Fluids
- Waves (Sound)

Physics 102

Microscopic

- Electricity+Magnetism
- Circuits
- Optics
- Modern
 - Atomic
 - Nuclear
 - Relativity

Physics 102: Lecture 01

Electric charge & Coulomb's Law

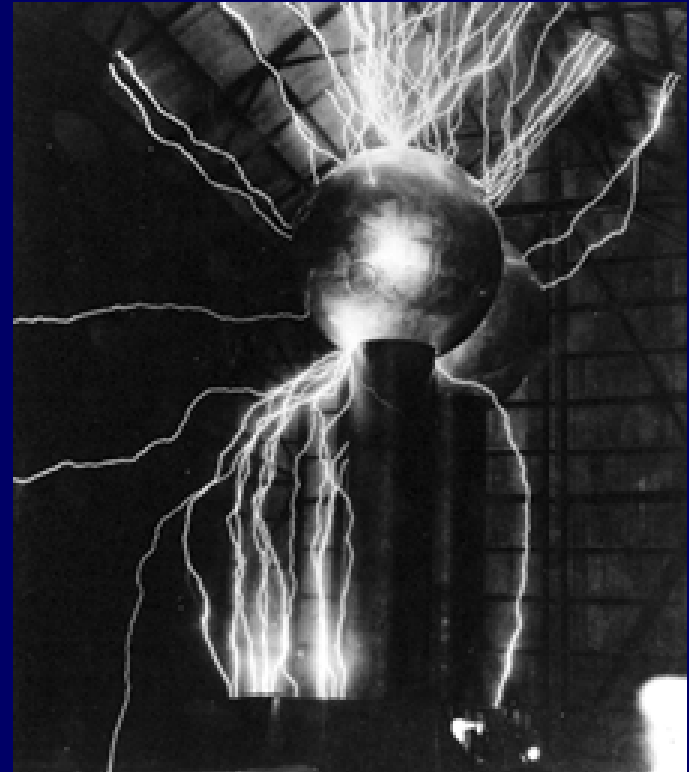

Origin of Charge

Charge is an intrinsic property of matter

- Two types:
 - Positive Charge
 - Negative Charge
 - Opposite charges attract, like charges repel.
 - The electric force is what holds stuff together

- Atoms are neutral
 - electron “orbits” the positive nucleus

proton electron

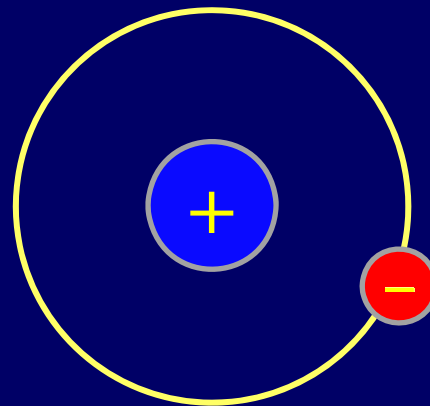
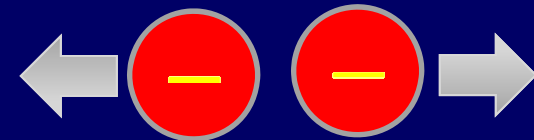
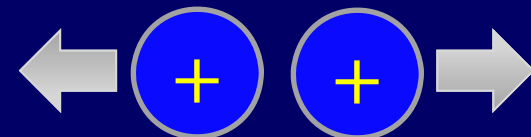
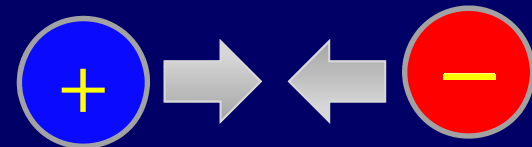

Conductors and Insulators



Q: How do electrons behave in a perfect conductor?

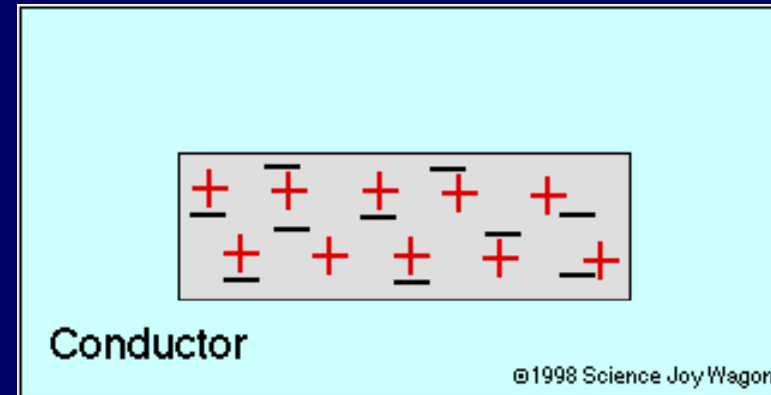

Q: How do electrons behave in a perfect insulator?

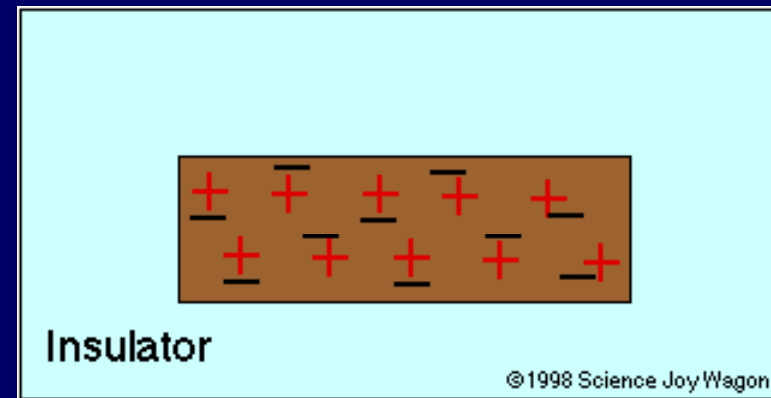
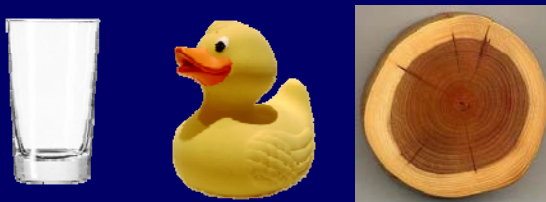

Most things are in between perfect conductor / insulator

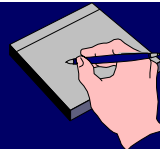

Electroscope (+demo)

- Conduction

- Charged rod is brought near scope
- Charged rod touches scope transferring some charge
- Scope is left w/ same charge as rod

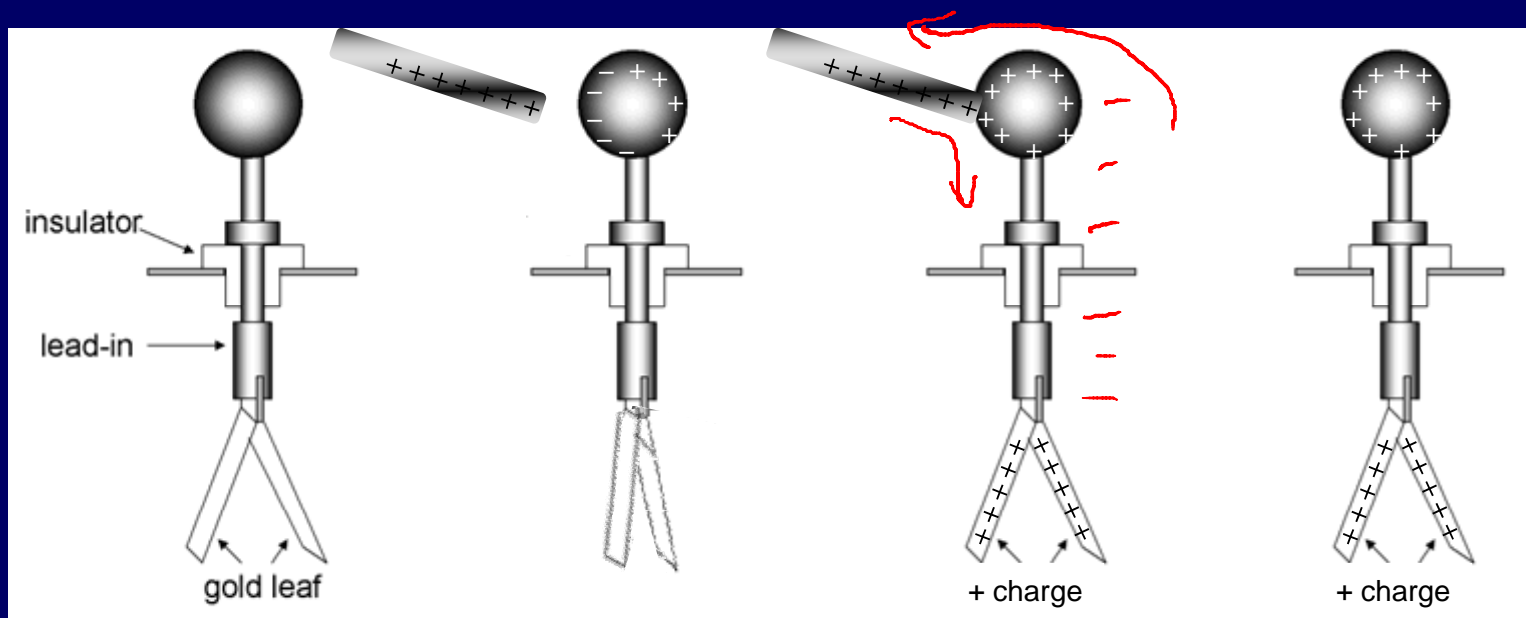

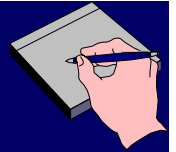

Electroscope (+demo)

- Induction

- Charged rod is brought near scope
- Scope is briefly grounded allowing charge to flow on (or off) scope
- Scope is left w/ opposite charge as rod

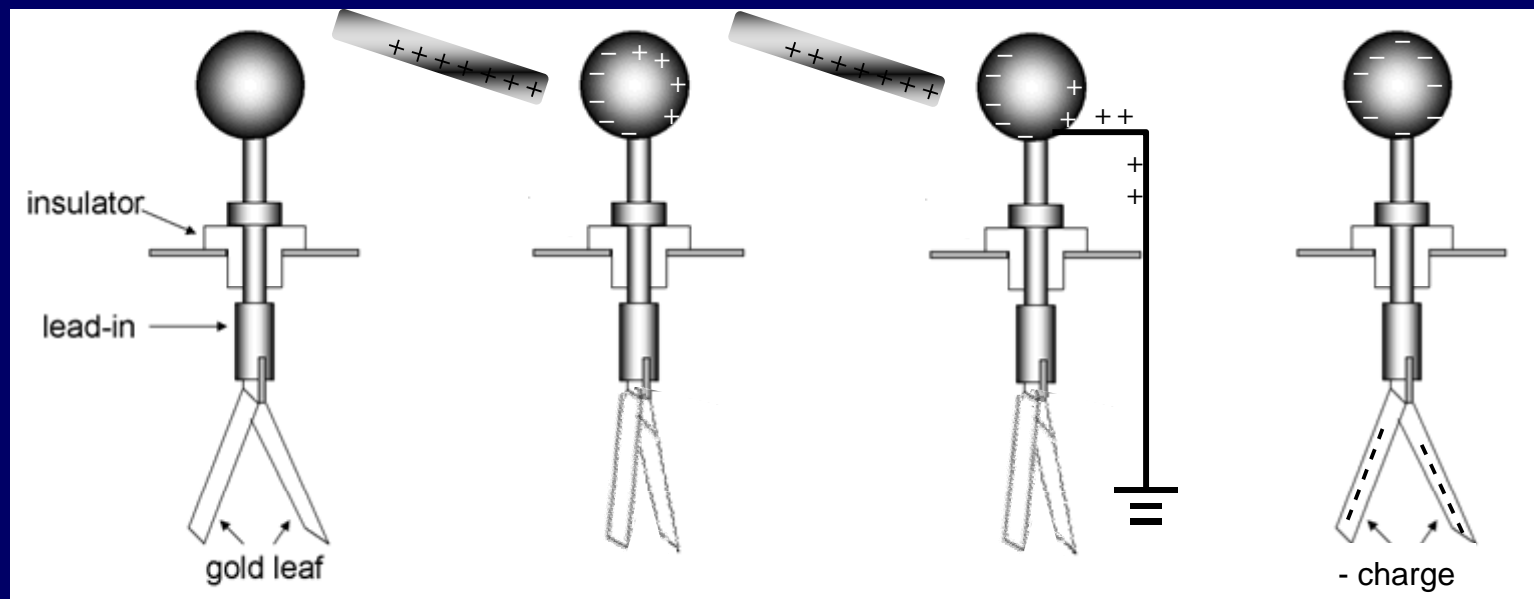



ACTS

A negatively charged rod is used to charge an electroscope by induction. What is the resulting net charge on the electroscope?

A) positive

B) zero

C) negative

- If the conducting electroscope were replaced by an insulating ball and then charged by induction as above, what would be the net charge on the ball.

A) positive

B) zero

C) negative

Coulomb's Law



Vector: magnitude + direction

Force between charges q_1 and q_2 separated a distance r :

Magnitude
 ≥ 0

$$F = k \frac{|q_1| |q_2|}{r^2}$$

$[N]$ $[C]$ $[C]$ $[m]$

“Coulomb constant”

$$k = 9 \times 10^9 \text{ Nm}^2/\text{C}^2$$

Or:
$$F = \frac{1}{4\pi\epsilon_0} \frac{q_1 q_2}{r^2}$$

“Permittivity of free space”

$$\epsilon_0 = 8.85 \times 10^{-12} \text{ C}^2/\text{Nm}^2$$

Direction

Opposite charges attract, like charges repel

Example

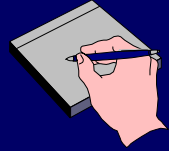

Coulomb's Law

- What is the magnitude of the force on the proton due to the electron in hydrogen?

$$F = k q_1 q_2 / r^2 \quad k = 9 \times 10^9 \text{ Nm}^2 / \text{C}^2$$

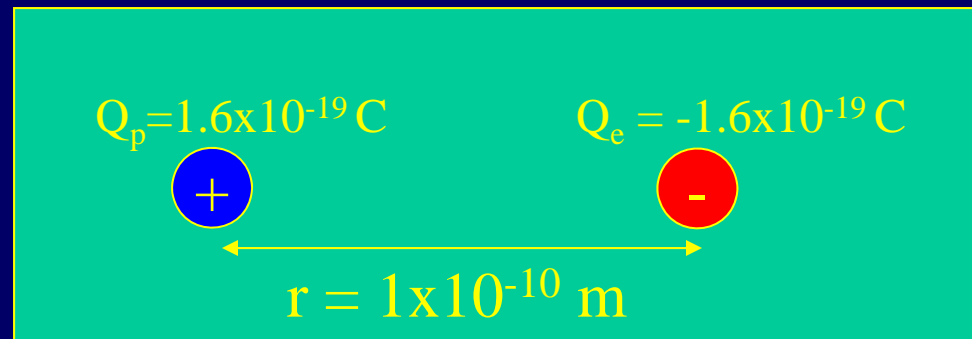

$$F = 9 \times 10^9 \frac{\text{Nm}^2}{\text{C}^2} \frac{(1.6 \times 10^{-19} \text{ C})(1.6 \times 10^{-19} \text{ C})}{(1 \times 10^{-10} \text{ m})^2} = 2.3 \times 10^{-8} \text{ N}$$



ACT: Coulomb's Law

- What is the direction of the force on the proton due to the electron?

(A) Left (B) Right (C) Zero

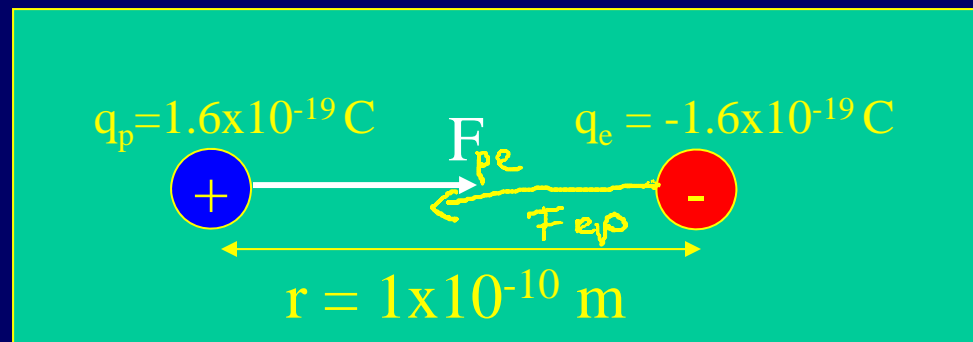

- What is the direction of the force on the electron due to the proton?

Electric dipole

A positive and negative charge of equal magnitude separated by a (usually small) distance

Ex: water

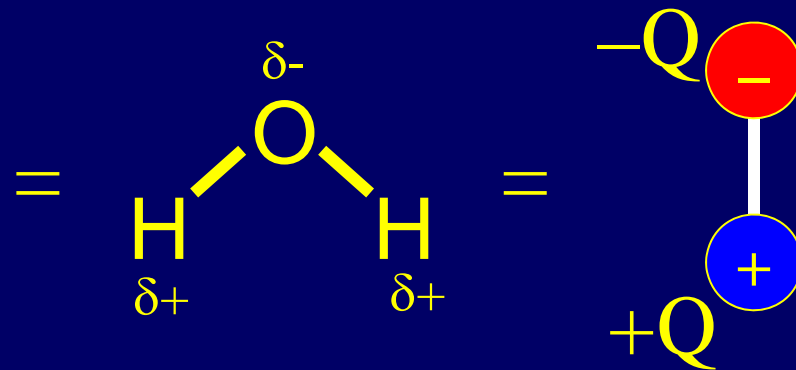
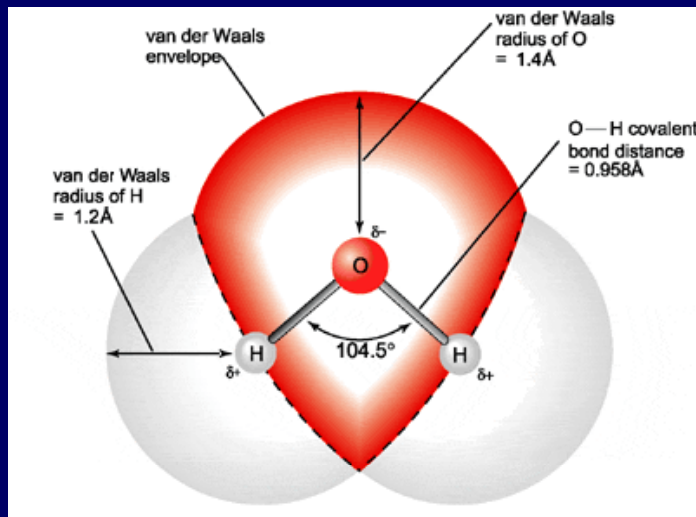



ACT

An electric dipole is placed near a large negative charge.
What is the net force on the two connected charges?

A) Left

B) Zero

C) Right

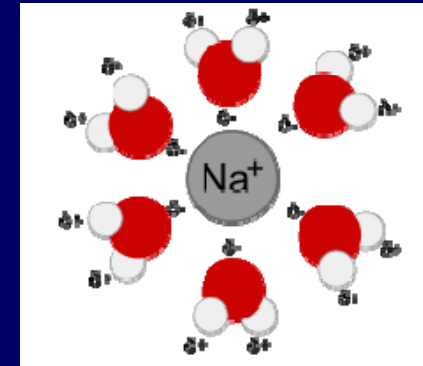
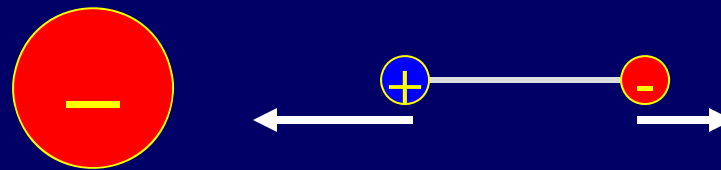

Positive charge is attracted (force to left)

Negative charge is repelled (force to right)

Positive charge is closer so force to left is larger.

$$F = k \frac{q_1 q_2}{r^2}$$



ACT: Induced Dipole

- An uncharged conducting sphere is hung next to a charged sphere. What happens when the uncharged sphere is released?

1) Nothing

2) Attracted to charged sphere.

3) Repelled from charged sphere.

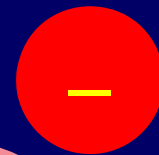

Induced Dipole

- An uncharged conducting sphere is hung next to a charged sphere. What happens when the uncharged sphere is released?

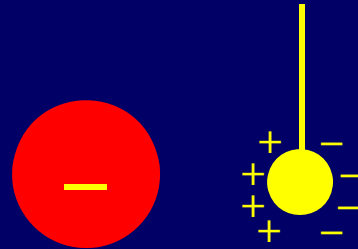

- 1) Negative charge attracts + repels -
- 2) A dipole is induced in the uncharged sphere
- 3) Since + is closer, attractive force is strongest

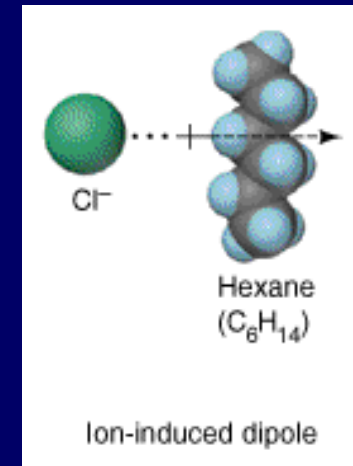

Demo: Induced Dipole

- An uncharged conducting sphere is hung between a charged sphere and a grounded sphere and held midway between the two. What happens when the uncharged sphere is released?

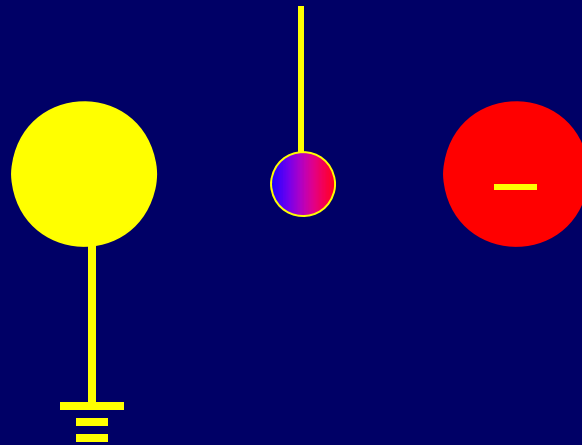

Summary of Today's Lecture

- The concept of charge
- Conductors and insulators
- Coulomb's Law for the force between charges

$$F = k \frac{q_1 q_2}{r^2}$$

- Much more on Coulomb's Law in next lecture
- Electric dipoles (permanent & induced)

Prior to next lecture....

- Do your CheckPoint
before 8:00 AM on the day of lecture.