

Name _____

Section _____

Date _____

Physics 211 PreLab #7: Rotational Dynamics II

Reading: Tipler
Chapter 10 - "Conservation of Angular Momentum"

Look Who's Torque-ing

In this lab, you will study in greater detail the relationship between torque, moment of inertia, and angular acceleration,

$$\tau = I \alpha,$$

using the torsion pendulum illustrated in Figure 1:

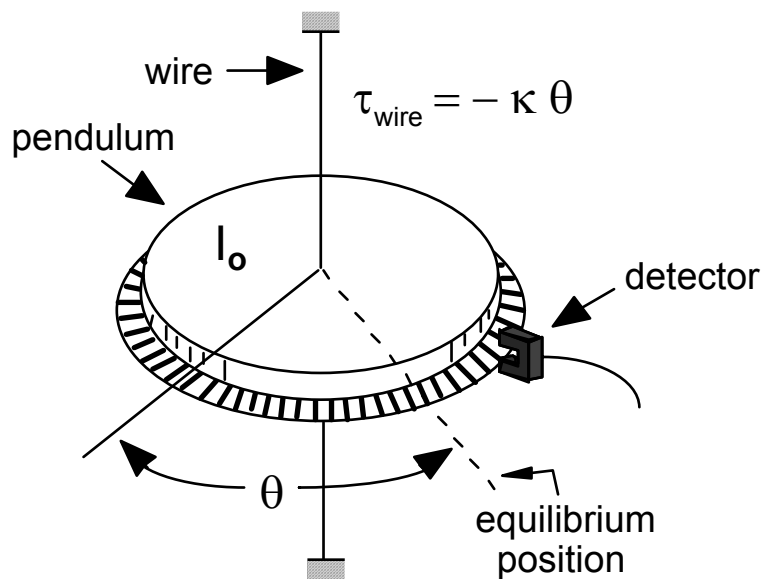

Figure 1. Experimental setup for Laboratory 7

In Investigation 1, you will study the balancing of torques acting on a torsion pendulum and find the “torsion constant” of the pendulum.

Answer the following question concerning Investigation 1.

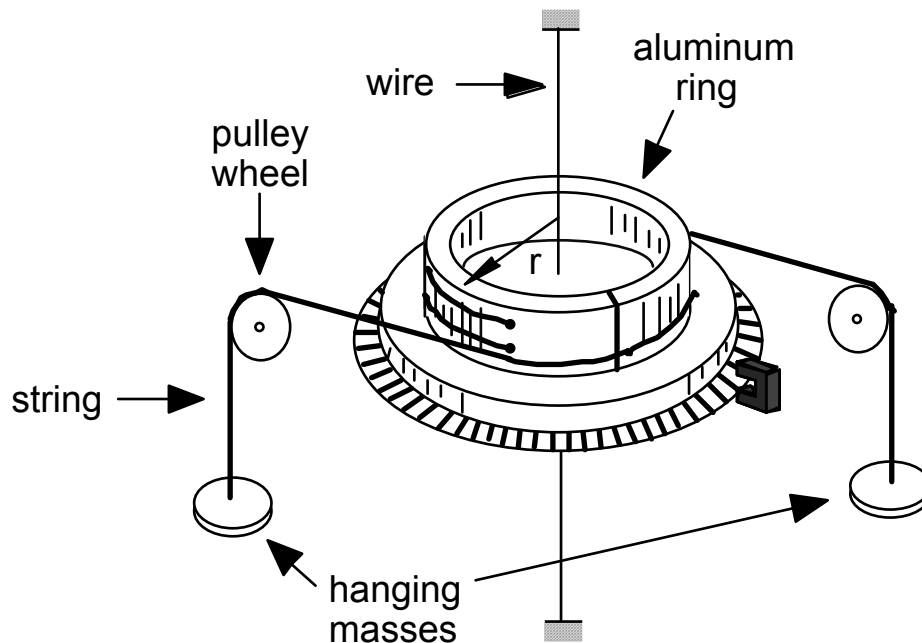

Figure 2. Experimental setup for Question 1

- Q1** - A torsion pendulum is attached to a wire as shown in Figure 2. When rotated an angle θ away from its equilibrium position, the wire exerts a “restoring” torque on the pendulum given by $\tau = -\kappa\theta$, where κ is a known constant called the “torsion constant” (see Figure 1). Two hanging masses, each with mass M , are attached to the pendulum (see Figure 2) in such a way that the pendulum is rotated away from equilibrium in the same clockwise “sense” for each mass. Write below an expression for the angle θ through which the torsion pendulum rotates in terms of r , M , g , and κ .

Q2 - A 55 gram mouse runs out to the end of the 17 cm long minute hand of a grandfather clock when the clock reads 10 minutes past the hour. What torque does the mouse's weight exert about the rotation axis of the clock hand (i.e., the axis perpendicular to the clock face)?

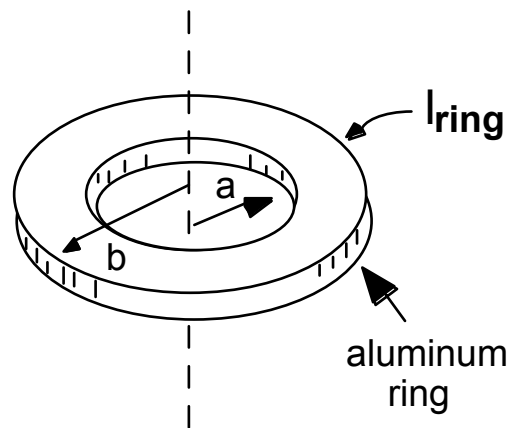

Figure 3. Aluminum ring for Question 3

Answer the following questions regarding Investigation 2.

Q3 - Determine the moment of inertia of the aluminum ring, I_{ring} , shown in Figure 3 given the following parameters associated with the ring: mass $M = 61$ grams; and inner and outer radii, $a = 6.35$ cm and $b = 7.6$ cm, respectively.

Useful Info:

$$I_{disk} = \frac{1}{2}Mr^2$$

$$I_{ring} = \underline{\hspace{2cm}} \text{ [kg}\cdot\text{m}^2\text{]}$$

$$I_{ring} = \frac{1}{2}M(a^2+b^2)$$

Q4 - A 108 gram Frisbee is 24 cm in diameter and has about half its mass spread uniformly in a disk, while the other half is concentrated in the rim of the Frisbee. With a quarter-turn (i.e., 90 degrees) flick of the wrist, a student starts the Frisbee rotating at 550 revolutions per minute (rpm). (a) What is the moment of inertia of the Frisbee? (b) What is the magnitude of the torque, assumed constant, that the student applies?