

Your Comments

This stuff was so difficult in high school, but after Gauss, it makes me feel warm and cozy inside.

I don't normally comment on these (actually, this is my first time), however, I would like to ask something. Can you please remind people not to talk during lecture? Last lecture, you made a joke about people wanting to sleep during lecture and therefore we needed to be quiet. Ironically, that was that was the first lecture that I flat out could not hear what you were saying. I think that you need to perhaps be a little bit more forceful for those who do not take a hint.

Im fine with packing the capacitors together in the diagrams, but for some reason I lose you when you unpack them.... is there a strategy to that??

Why is that prelecture questions and checkpoints questions, as well as some questions in lectures are easy and understandable. But when it comes to homework, I find I can do nothing. Where can I ask for help about this?

Is there any possibility on extending the homework deadline due to the fact that next week is an exam week? (211 homework was extended) Please and Thank you! It'd be greatly appreciated.

Being an ECE major, i'm loving the whole series and parallel thing.

Exam Logistics

1) EXAM 1: WED February 13th at 7pm

- Sign Up in Gradebook for Conflict Exam at 5:15pm if desired
- If you have double conflict please email Prof. Aksimentiev
- MATERIAL: Lectures 1 - 8

2) EXAM 1 PREPARATION

- Old Exams are a good way to assess what you need to know
- Prelecture of Tim solving exam from Fall 2010 available

3) Extra Office Hours (Tuesday/ Wednesday next week in 276 Loomis)

Physics 212

Lecture 8

Today's Concept:

Capacitors

(Capacitors in a circuits, Dielectrics, Energy in capacitors)

Simple Capacitor Circuit

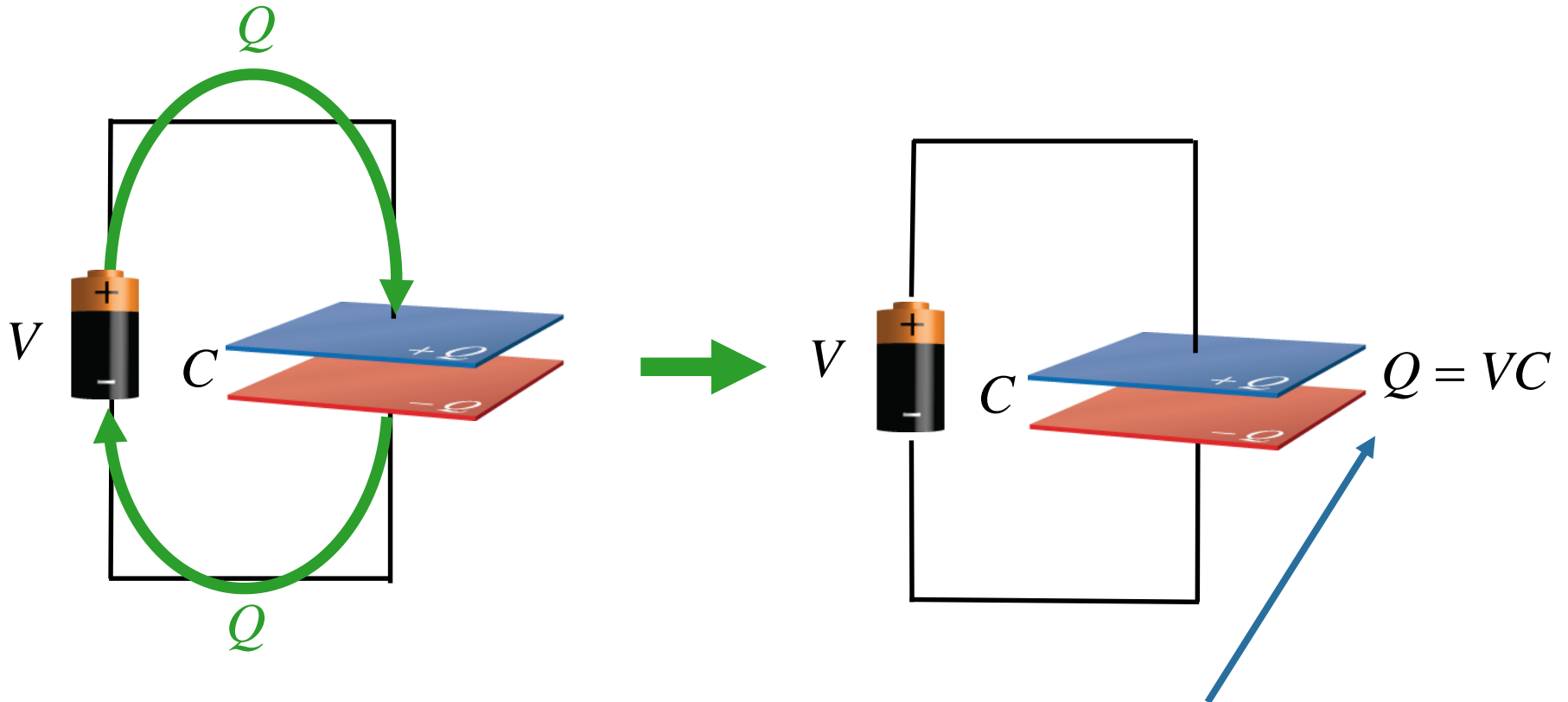

This “ Q ” really means that the battery has moved charge Q from one plate to the other, so that one plate holds $+Q$ and the other $-Q$.

Parallel Capacitor Circuit

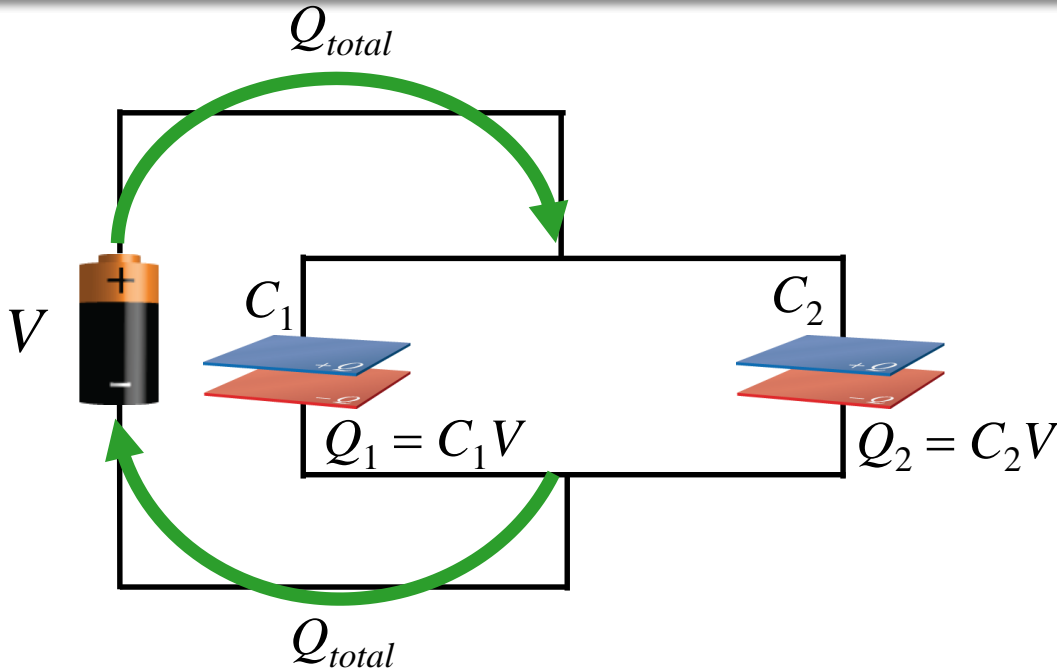

Key point: V is the same for both capacitors

Key Point: $Q_{total} = Q_1 + Q_2 = VC_1 + VC_2 = V(C_1 + C_2)$

$$C_{total} = C_1 + C_2$$

Series Capacitor Circuit

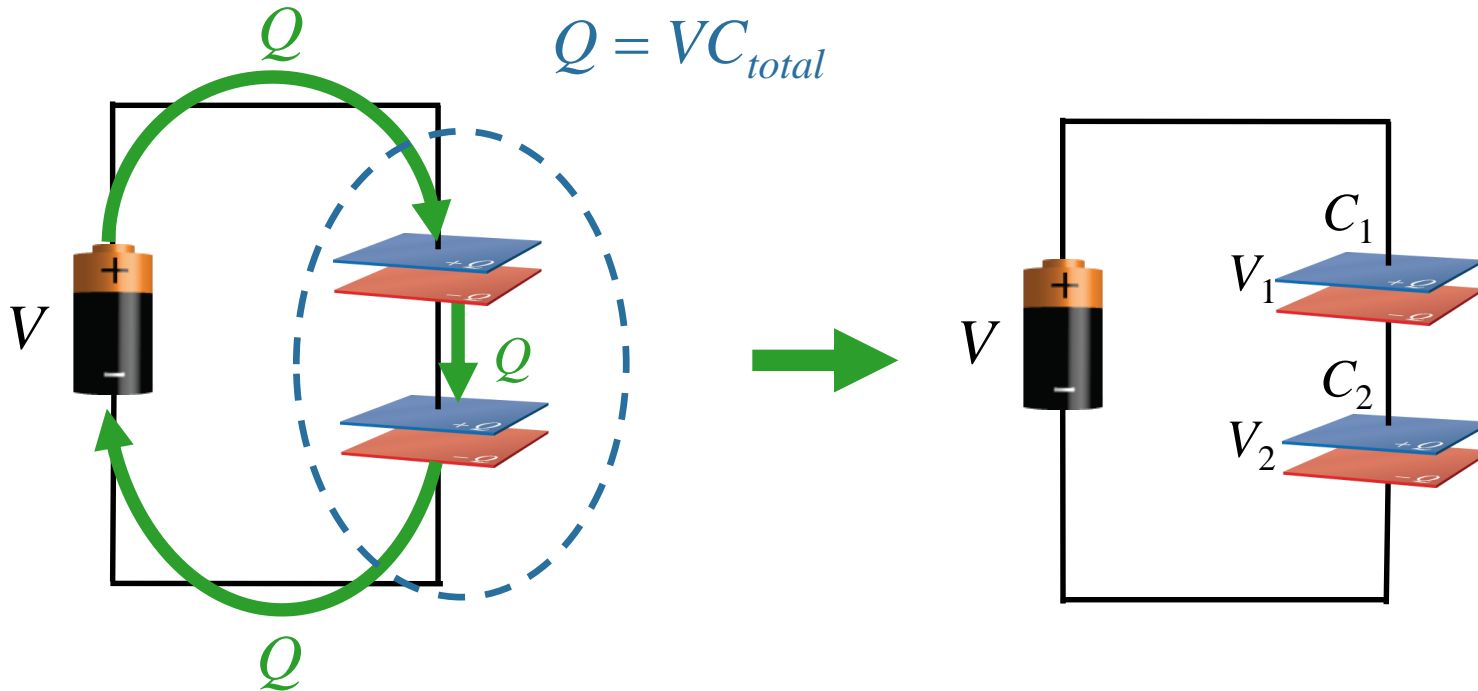

Key point: Q is the same for both capacitors

Key point: $Q = VC_{total} = V_1C_1 = V_2C_2$

Also: $V = V_1 + V_2$ $\longrightarrow Q/C_{total} = Q/C_1 + Q/C_2$

$$\frac{1}{C_{total}} = \frac{1}{C_1} + \frac{1}{C_2}$$

Checkpoint 1

Which has lowest total capacitance:

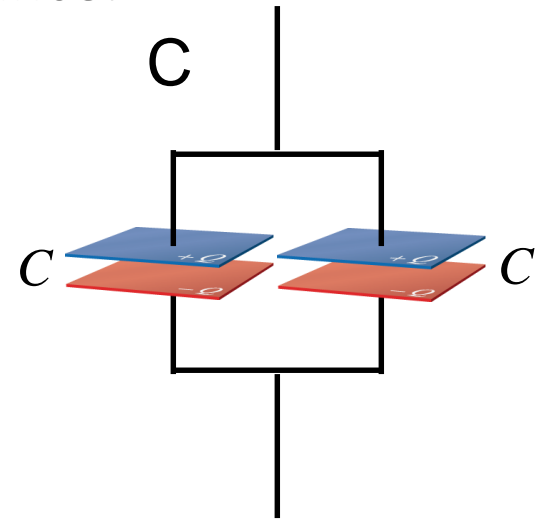
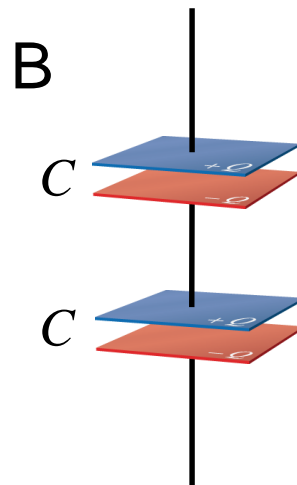
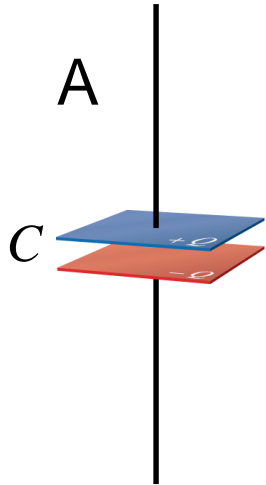

$$\begin{aligned} 1/C_{total} &= 1/C + 1/C \\ &= 2/C \end{aligned}$$

$$C_{total} = C/2$$

$$C_{total} = C$$

$$C_{total} = 2C$$

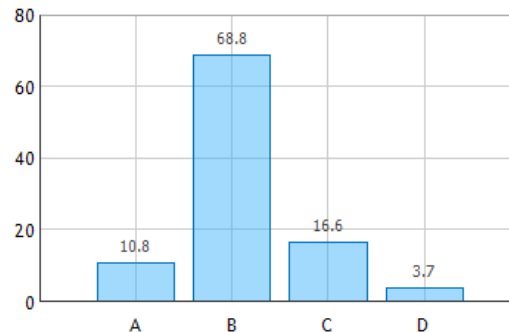

Checkpoint 2

Which has lowest total capacitance?

- A) Single Capacitor B) 4 Capacitors C) Same

:

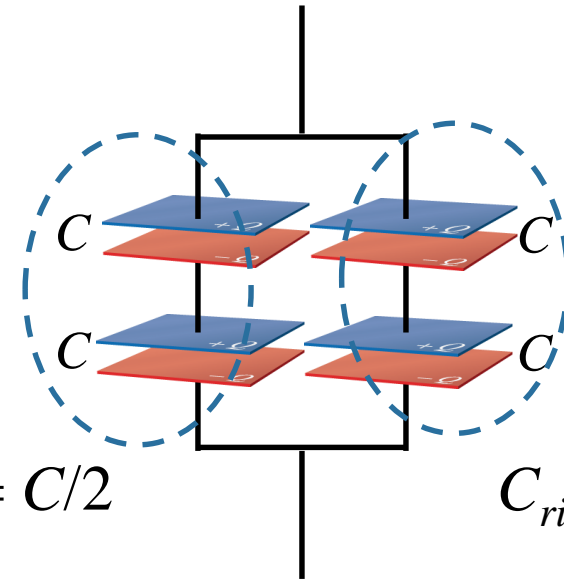
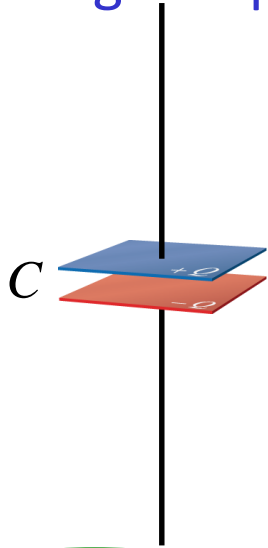

$$C_{left} = C/2$$

$$C_{right} = C/2$$

$$C_{total} = C$$

$$C_{total} = C_{left} + C_{right}$$

$$C_{total} = C$$

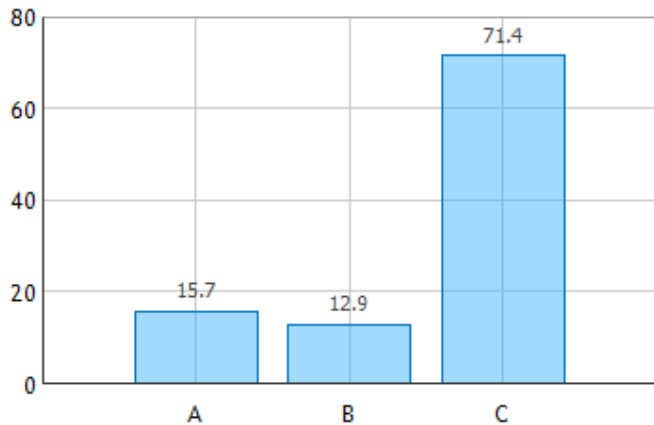

Similar to CheckPoint 3

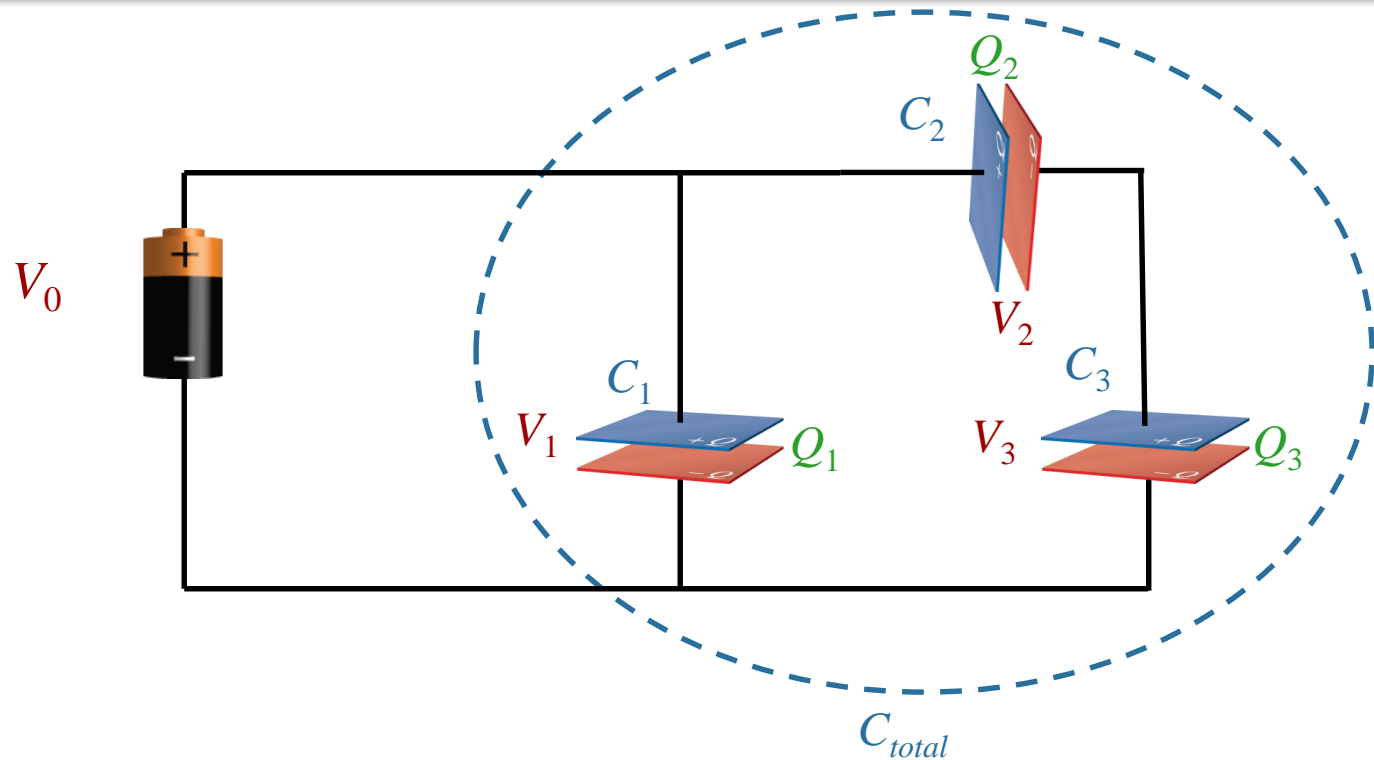

Which of the following is **NOT** necessarily true:

- A) $V_0 = V_1$
- B) $C_{total} > C_1$
- C) $V_2 = V_3$**
- D) $Q_2 = Q_3$
- E) $V_1 = V_2 + V_3$

Checkpoint 3



A circuit consists of three unequal capacitors C_1 , C_2 , and C_3 which are connected to a battery of voltage V_0 . The capacitance of C_2 is twice that of C_1 . The capacitance of C_3 is three times that of C_1 . The capacitors obtain charges Q_1 , Q_2 , and Q_3 .

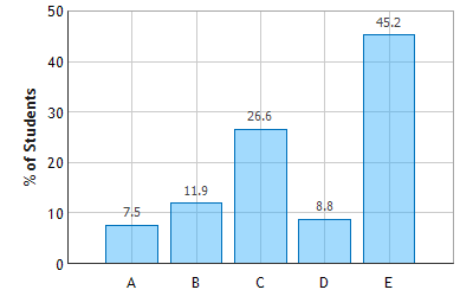
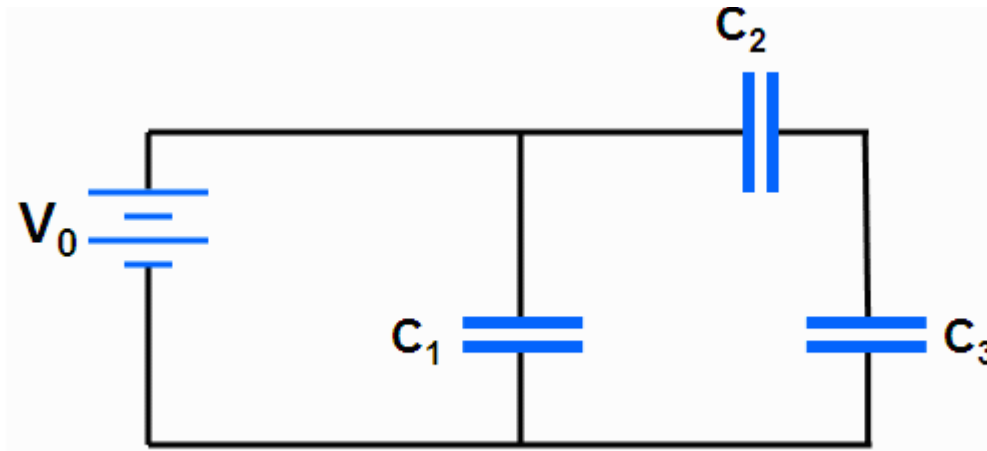

~~A.~~ $Q_1 > Q_3 > Q_2$ ~~B.~~ $Q_1 > Q_2 > Q_3$ **C.** $Q_1 > Q_2 = Q_3$ **D.** $Q_1 = Q_2 = Q_3$ **E.** $Q_1 < Q_2 = Q_3$

1. See immediately: $Q_2 = Q_3$ (capacitors in series)

2. How about Q_1 vs. Q_2 and Q_3 ? Calculate C_{23} first.

$$\frac{1}{C_{23}} = \frac{1}{C_2} + \frac{1}{C_3} = \frac{1}{2C_1} + \frac{1}{3C_1} = \frac{5}{6C_1}$$



$$C_{23} = \frac{6}{5}C_1$$



$$Q_1 = C_1 V_0$$

$$Q_{23} = Q_2 = Q_3 = C_{23} V_0 = \frac{6}{5} C_1 V_0$$

Energy in a Capacitor

In Prelecture 7 we calculated the work done to move charge Q from one plate to another:

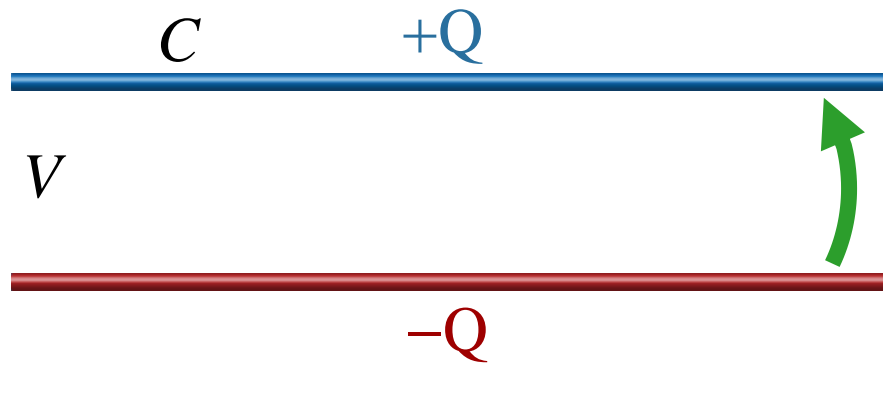
$$\begin{aligned} U &= \frac{1}{2}QV \\ &= \frac{1}{2}CV^2 \\ &= \frac{1}{2}Q^2/C \end{aligned} \quad \left. \vphantom{\begin{aligned} U &= \frac{1}{2}QV \\ &= \frac{1}{2}CV^2 \\ &= \frac{1}{2}Q^2/C \end{aligned}} \right\} \text{Since } Q = VC$$

This is potential energy waiting to be used...

Dielectrics

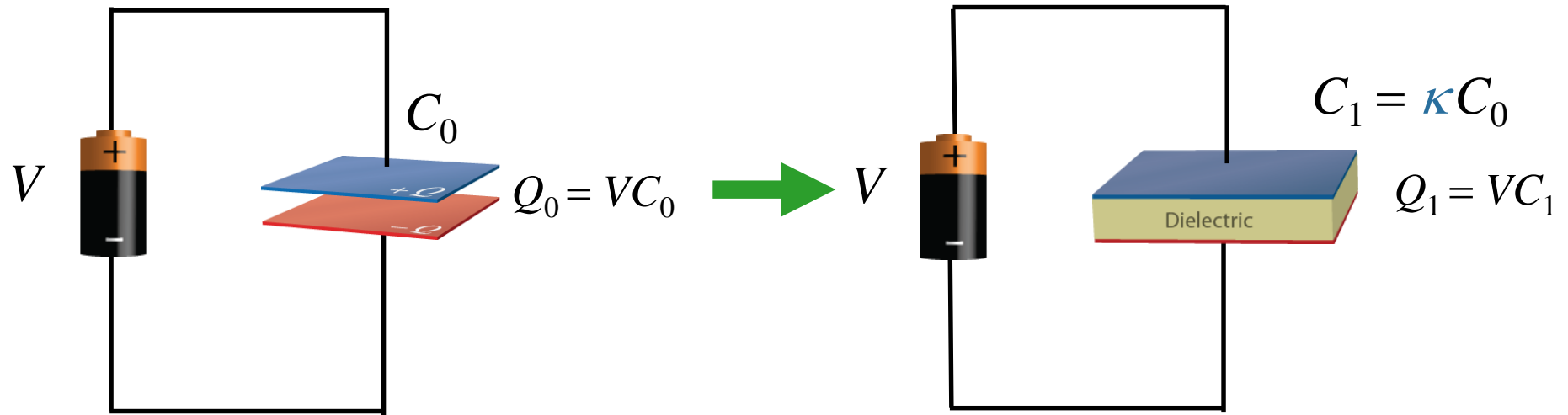

By adding a dielectric you are just making a new capacitor with larger capacitance (factor of κ)

Messing with Capacitors

If connected to a battery V stays constant

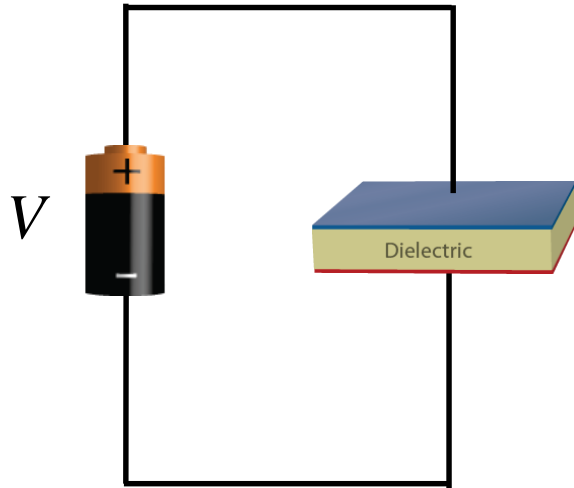

$$V_1 = V$$

$$C_1 = \kappa C$$



$$Q_1 = C_1 V_1$$

$$= \kappa C V = \kappa Q$$

If isolated then total Q stays constant

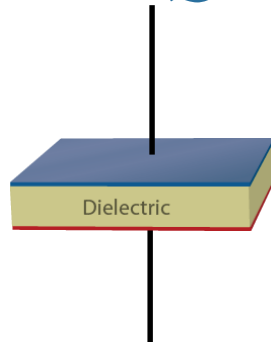

$$Q_1 = Q$$

$$C_1 = \kappa C$$



$$V_1 = Q_1 / C_1$$

$$= Q / \kappa C = V / \kappa$$

Checkpoint 4a



Two identical parallel plate capacitors are given the same charge Q , after which they are disconnected from the battery. Then, a dielectric is placed between the plates of C_2

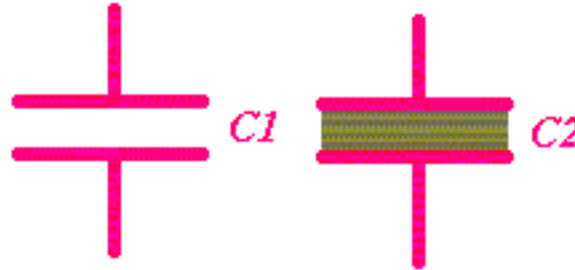

Compare the voltages of the two capacitors.

A $V_1 > V_2$ B $V_1 = V_2$ C $V_1 < V_2$

“ $Q_1=Q_2$, but $C_2>C_1$ ”

“The dielectric was added once the V had already been established, so it does nothing.”

“Dielectrics give higher capacitance, with the same Q this means higher V .”

Capacitors with and without a Dielectric:
Question 1 (N = 799)

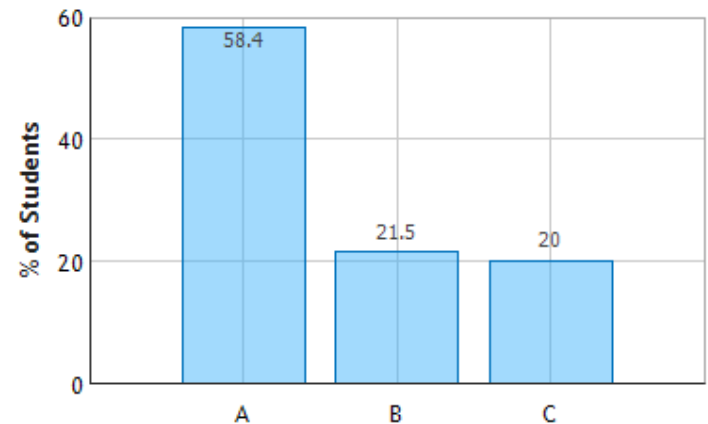

Messing with Capacitors Clicker Question



Two identical parallel plate capacitors are connected to identical batteries. Then a dielectric is inserted between the plates of capacitor C_1 . Compare the energy stored in the two capacitors.

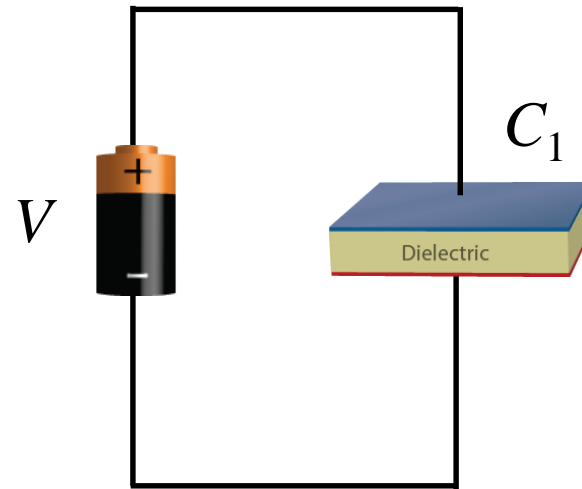
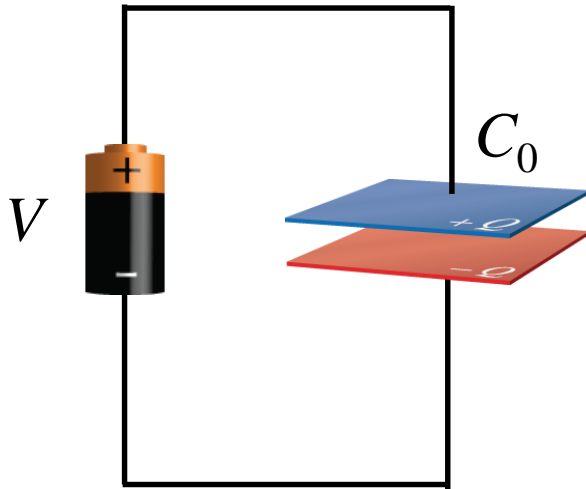

A) $U_1 < U_0$

B) $U_0 = U_1$

C) $U_1 > U_0$

Compare using $U = \frac{1}{2}CV^2$

$$U_1/U_0 = \kappa$$

→ Potential Energy goes UP

CheckPoint 4b



Two identical parallel plate capacitors are given the same charge Q , after which they are disconnected from the battery. Then, a dielectric is placed between the plates of C_2

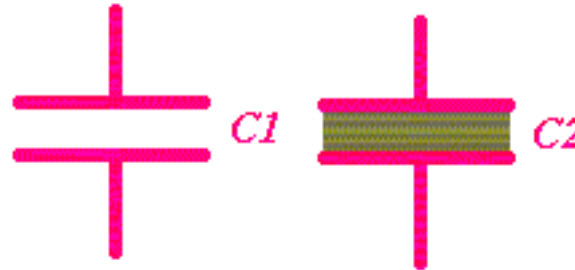

Compare the potential energy stored by the two capacitors.

- A) $U_1 > U_2$ B) $U_1 = U_2$ C) $U_1 < U_2$

$U = QV/2$ and since charge is the same but voltage is lower in case 2, U_2 is lower.

Since a battery isn't attached the potential energy will stay the same.

dielectrics increase C which in turn increases U

Capacitors with and without a Dielectric:
Question 3 (N = 798)

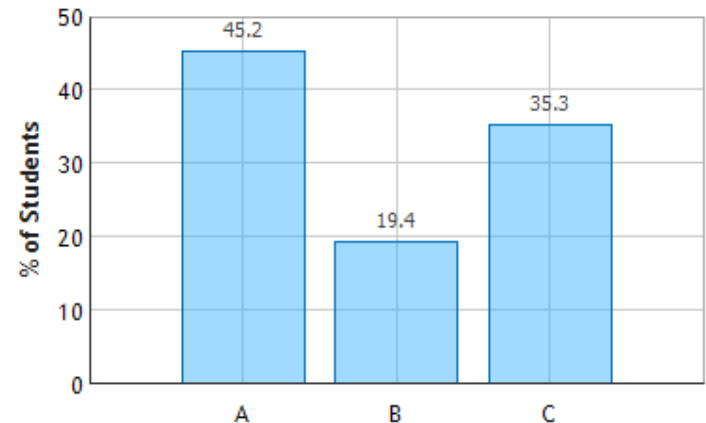

Checkpoint 4c



Two identical parallel plate capacitors are given the same charge Q , after which they are disconnected from the battery. After C_2 has been charged and disconnected, it is filled with a dielectric. **The two capacitors are now connected to each other by wires as shown. How will the charge redistribute itself, if at all?**

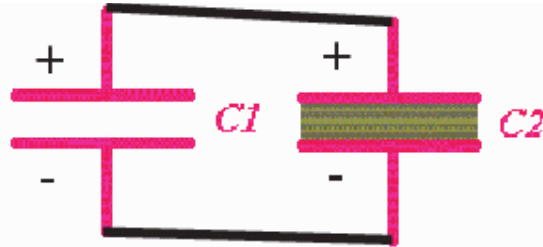

- A. The charges will flow so that the charge on C_1 will become equal to the charge on C_2 .
- B. The charges will flow so that the energy stored in C_1 will become equal to the energy stored in C_2 .
- C. The charges will flow so that the potential difference across C_1 will become the same as the potential difference across C_2 .
- D. No charges will flow. The charge on the capacitors will remain what it was before they were connected.

V must be the same !!

Q: $\frac{Q_1}{C_1} = \frac{Q_2}{C_2} \rightarrow Q_1 = \frac{C_1}{C_2} Q_2$

U: $U_1 = \frac{1}{2} C_1 V^2$
 $U_2 = \frac{1}{2} C_2 V^2 \rightarrow U_1 = \frac{C_1}{C_2} U_2$

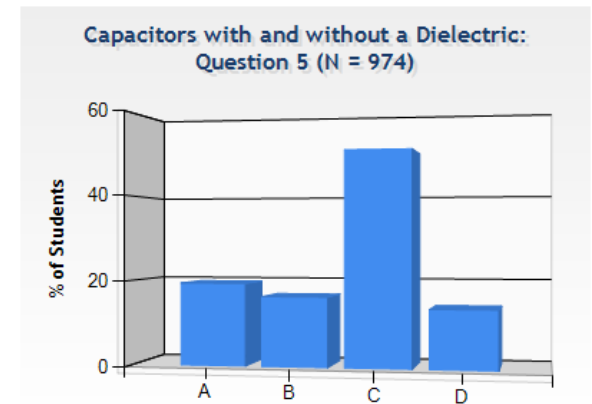

Calculation

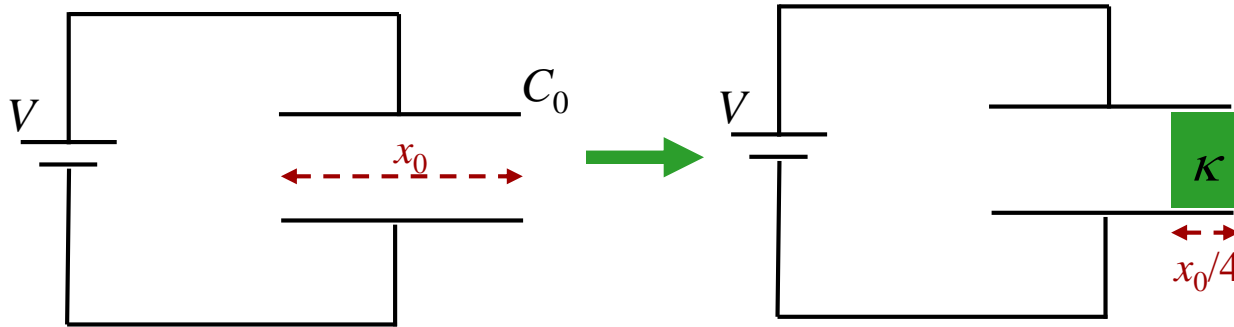

An air-gap capacitor, having capacitance C_0 and width x_0 is connected to a battery of voltage V .

A dielectric (κ) of width $x_0/4$ is inserted into the gap as shown.

What is Q_f , the final charge on the capacitor?

Conceptual Analysis:

$$C \equiv \frac{Q}{V}$$

What changes when the dielectric added?

- A) Only C B) only Q C) only V **D) C and Q** E) V and Q

Adding dielectric changes the physical capacitor



C changes

V does not change and C changes



Q changes

Calculation

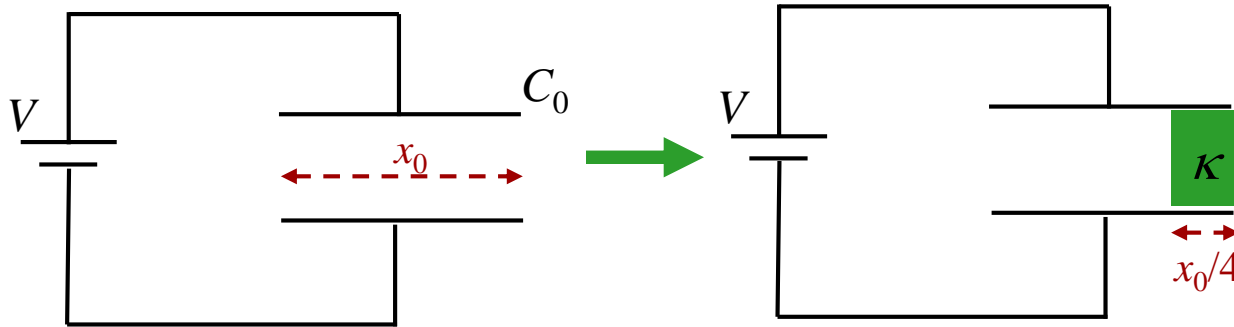

An air-gap capacitor, having capacitance C_0 and width x_0 is connected to a battery of voltage V .

A dielectric (κ) of width $x_0/4$ is inserted into the gap as shown.

Strategic Analysis:

- Calculate new capacitance C
- Apply definition of capacitance to determine Q

What is Q_f , the final charge on the capacitor?

To calculate C , let's first look at:



A) $V_{left} < V_{right}$

B) $V_{left} = V_{right}$

C) $V_{left} > V_{right}$

The conducting plate is an equipotential !

Calculation

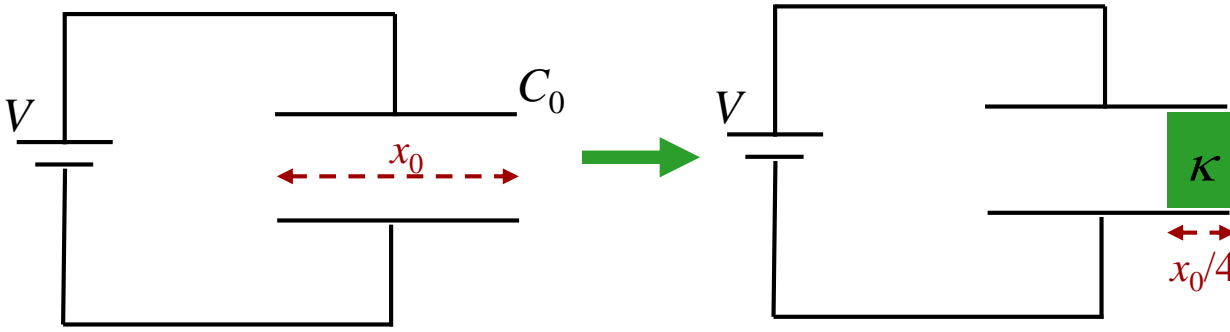

An air-gap capacitor, having capacitance C_0 and width x_0 is connected to a battery of voltage V .

A dielectric (κ) of width $x_0/4$ is inserted into the gap as shown.

What is Q_f , the final charge on the capacitor?

Can consider capacitor to be two capacitances, C_1 and C_2 , in parallel

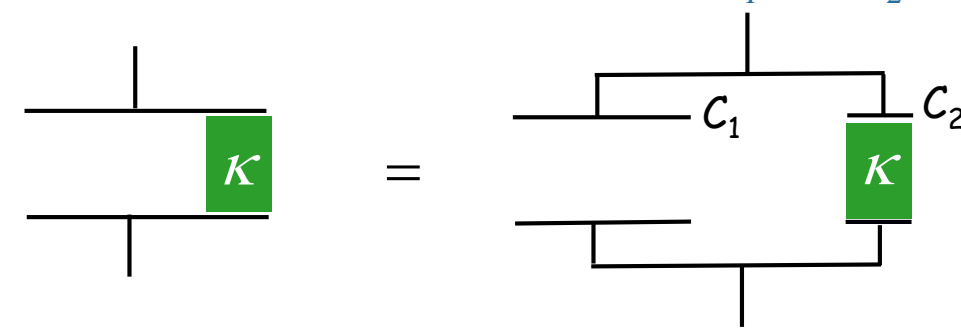

What is C_1 ?

- A) $C_1 = C_0$
- B) $C_1 = 3/4 C_0$**
- C) $C_1 = 4/3 C_0$
- D) $C_1 = 1/4 C_0$

In general. For parallel plate capacitor: $C = \epsilon_0 A / d$

$$\begin{matrix} A = 3/4 A_0 \\ d = d_0 \end{matrix} \quad \rightarrow \quad C_1 = 3/4 (\epsilon_0 A_0 / d_0) \quad \rightarrow \quad \boxed{C_1 = 3/4 C_0}$$

Calculation

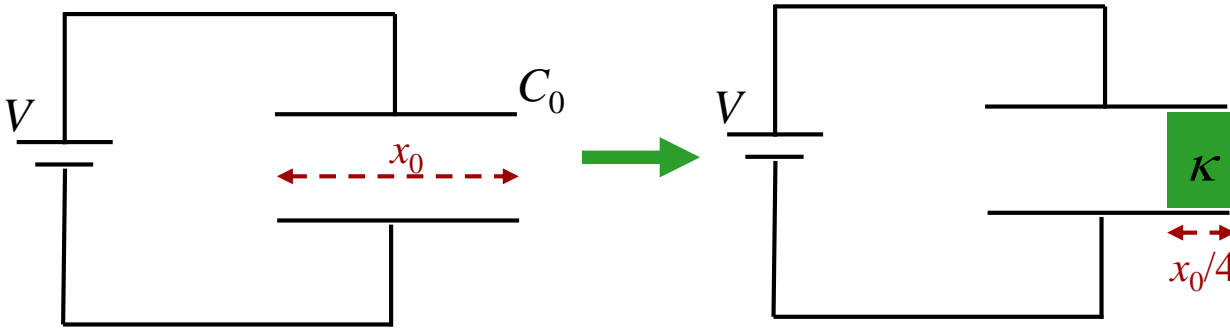

An air-gap capacitor, having capacitance C_0 and width x_0 is connected to a battery of voltage V .

A dielectric (κ) of width $x_0/4$ is inserted into the gap as shown.

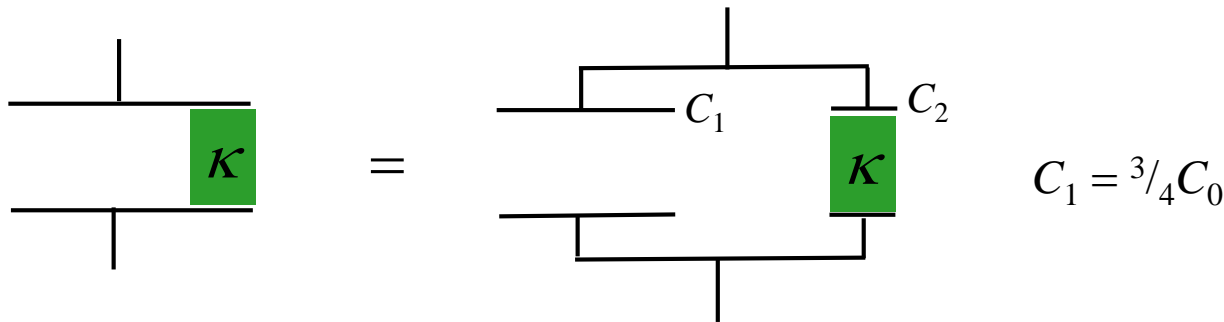

What is Q_f , the final charge on the capacitor?

What is C_2 ?

A) $C_2 = \kappa C_0$

B) $C_2 = \frac{3}{4} \kappa C_0$

C) $C_2 = \frac{4}{3} \kappa C_0$

D) $C_2 = \frac{1}{4} \kappa C_0$

In general. For parallel plate capacitor filled with dielectric: $C = \kappa \epsilon_0 A/d$

$$\begin{array}{l}
 A = \frac{1}{4} A_0 \\
 d = d_0
 \end{array}
 \quad \Rightarrow \quad
 C = \frac{1}{4} (\kappa \epsilon_0 A_0 / d_0)
 \quad \Rightarrow \quad
 C_2 = \frac{1}{4} \kappa C_0$$

Calculation

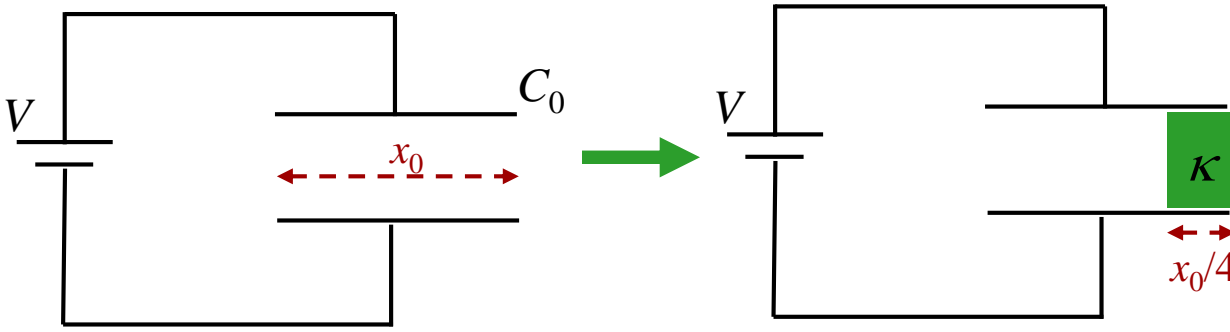

An air-gap capacitor, having capacitance C_0 and width x_0 is connected to a battery of voltage V .

A dielectric (κ) of width $x_0/4$ is inserted into the gap as shown.

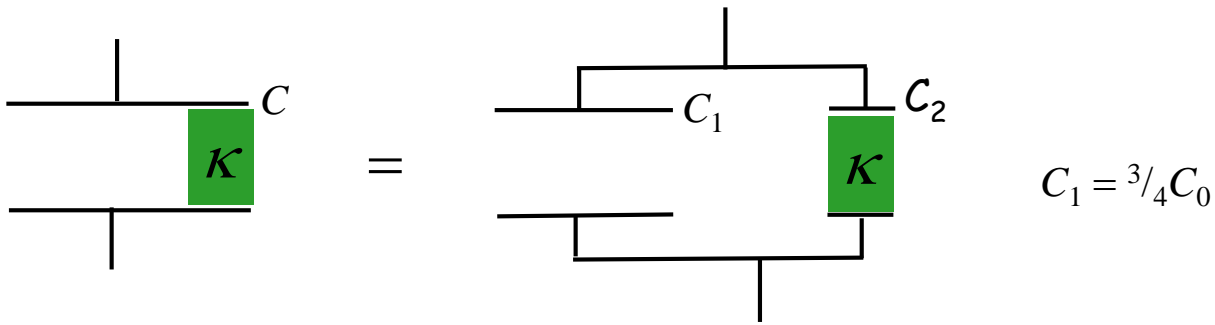

$$C_1 = \frac{3}{4}C_0$$

$$C_2 = \frac{1}{4} \kappa C_0$$

What is Q_f , the final charge on the capacitor?

What is C ?

A) $C = C_1 + C_2$

B) $C = C_1 + \kappa C_2$

C) $C = \left(\frac{1}{C_1} + \frac{1}{C_2} \right)^{-1}$

$C =$ parallel combination of C_1 and C_2 : $C = C_1 + C_2$

$\rightarrow C = C_0 \left(\frac{3}{4} + \frac{1}{4} \kappa \right)$

Calculation

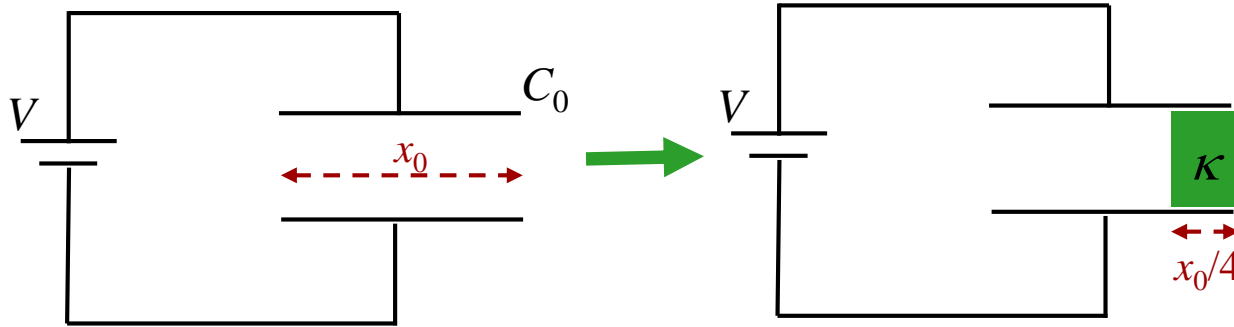

An air-gap capacitor, having capacitance C_0 and width x_0 is connected to a battery of voltage V .

A dielectric (κ) of width $x_0/4$ is inserted into the gap as shown.

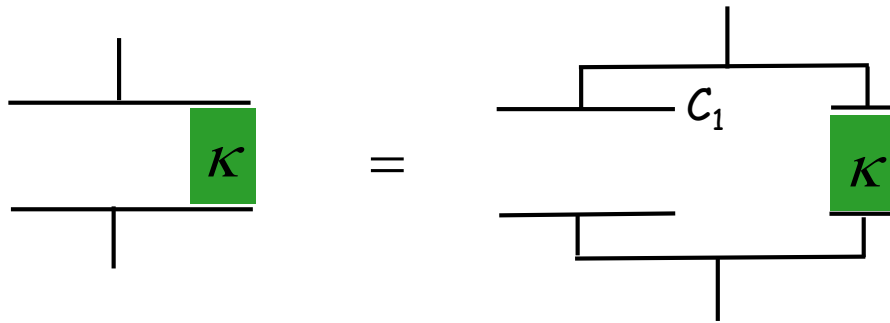

What is Q_f , the final charge on the capacitor?

$$C_1 = \frac{3}{4}C_0$$

$$C_2 = \frac{1}{4}\kappa C_0$$

$$\rightarrow C = C_0 \left(\frac{3}{4} + \frac{1}{4}\kappa \right)$$

What is Q ?

$$C \equiv \frac{Q}{V} \rightarrow Q = VC$$

$$Q_f = VC_0 \left(\frac{3}{4} + \frac{1}{4}\kappa \right)$$