

Particle Resuspension



Group 4: John Benson, Laura Nussel, Pedro Prado, Natalia Raymundi

February 16, 2023

Motivation

Nuclear Fallout and Particle Resuspension

Motivation

- When nuclear explosions or nuclear meltdowns occur, there is fallout
- There are good models for how that radioactive waste settles
- However, in the event of an explosion or meltdown, first responders often need to enter the area, or evacuations are needed
- There is not enough data on the mechanical resuspension of radioactive particles
- Our study aims to characterize particle resuspension due to pedestrian traffic

Particle size is important!

- Particle size is more important than the weight of the particle
- Particles $<50\ \mu\text{m}$ are generally not resuspended by wind, and require mechanical forces for resuspension
- The size of particles is extremely important in determining the potential hazards of resuspension:
 - Particles over $15\ \mu\text{m}$ are caught in the nasal passages and generally do less harm
 - Between 3.5 and $15\ \mu\text{m}$ particles can be inhaled and damage the lungs
 - Particles below $3.5\ \mu\text{m}$ can be deposited directly into the alveoli, causing serious damage to the lungs
- We aim to study particles $< 50\ \mu\text{m}$

Our study aims to model resuspension of particles $< 50 \mu\text{m}$

- We aim to measure the degree of particle resuspension from a pedestrian walking on a concrete surface
- This will be accomplished using a Plantower PMS5003 particle sensor interfaced with an Arduino Mega 2560
- The experiment will take place on an indoor concrete floor seeded with particles of varying sizes
- A person will walk past a sensor set in the breathable zone (4-6 ft high), and the plantower sensor will determine the number of particles that are suspended in the air as a function of time

Experiment

Variables of Interest and Factors to Control

Variables of Interest

- There are many factors to consider when building this experiment, such as:
 - Particle Size
 - Walking Surface
 - Walking Speed
 - Height of the sensor
 - Temperature, pressure and humidity conditions
 - Wind/Air movement
 - Time for resuspension

Considerations and Controls

To reduce the number of trials, as well as increase the viability of the initial data, we chose experimental conditions that reduce the number of variables:

- The experiment will be performed indoors, on a concrete surface
 - Indoor experiments control wind factor and concrete simulates an urban environment, which is where we would like to apply this studies results
- The height of the sensor will be set in the breathable zone (4-6ft)
 - This is the most important zone, as most people are in this height range
- The floor will be cleaned, a control will be taken, and then the floor will be seeded with different particle sizes for each trial
 - Allows control over how many particles are on the floor prior to each trial

Method

- A plantower sensor with the necessary components will be set in the breathable zone, indoors, in a place with a clean floor.
- A person with clean shoes will walk by the plantower and then along a straight path in front of the sensor
- The path will then be seeded with particles of the desired size for the specific trial
- The same person will again walk by the plantower and then along a straight path in front of the sensor
- Data on the concentration of particles in the air will be recorded by the Plantower
- We will run multiple trials for each particle size

Final Experimental Considerations

- The pressure, temperature and humidity in the environment will be recorded by a BME680
- However, we will not control for these factors
- A motion sensor will detect when the pedestrian passes the sensors, allowing us to correlate the timing of the walk with the data
- An additional Plantower sensor may be implemented to give additional data, once the first is working
- Trials varying height (in the 4-6 ft range), walking speed, pedestrian weight, and other variables may be taken given sufficient time

Housing and Circuit Elements

Circuit Components Needed

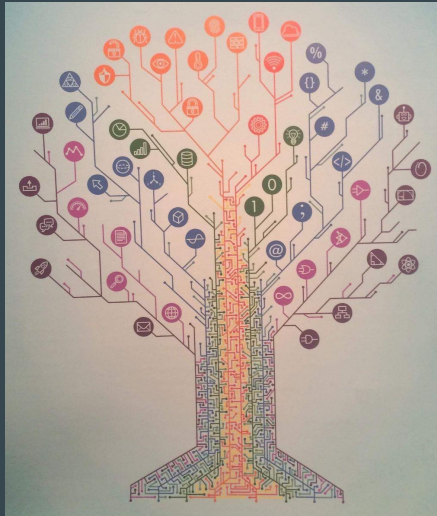

- Arduino Mega 2560
 - Battery Pack
 - Plantower Sensor
 - LCD
 - Micro SD
 - BME680
 - DS3231 (RTC)
 - Motion Sensor
-

Layout of Circuit Components and Housing

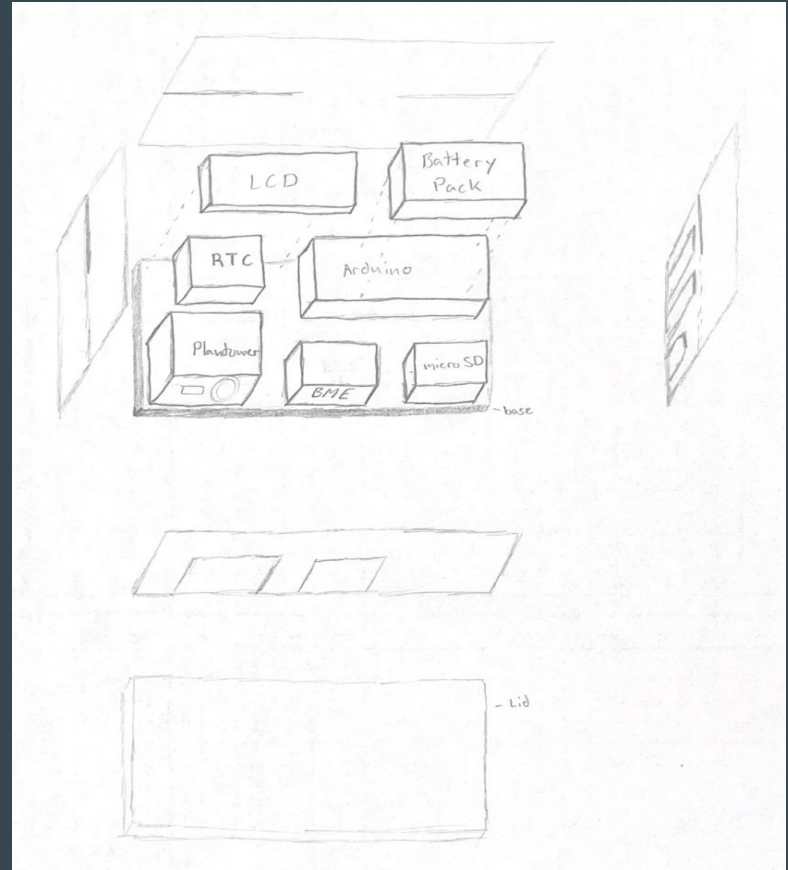
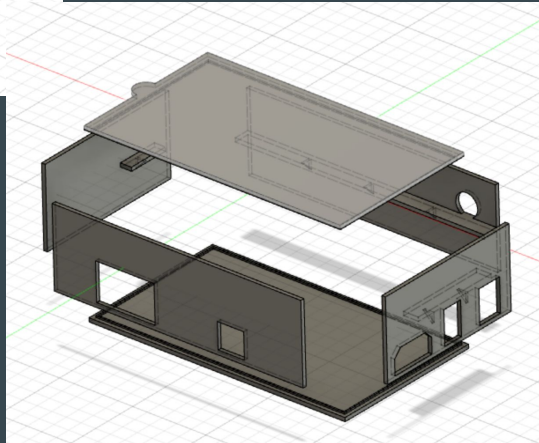
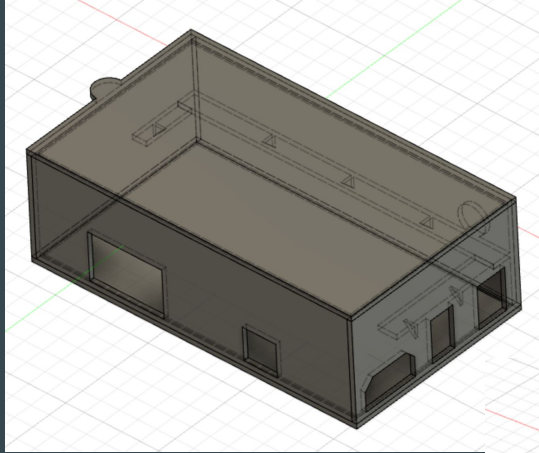

Data Acquisition System

Collection and Analysis

Particle size affects resuspension

- Nuclear particles have different sizes
 - They vary from a few to a hundred micrometers
- Particles over 50 μm are more hardly resuspended
 - We only need to study smaller particles
- The PMS5003 sensor detects particles of sizes from 0.3 μm to 10 μm

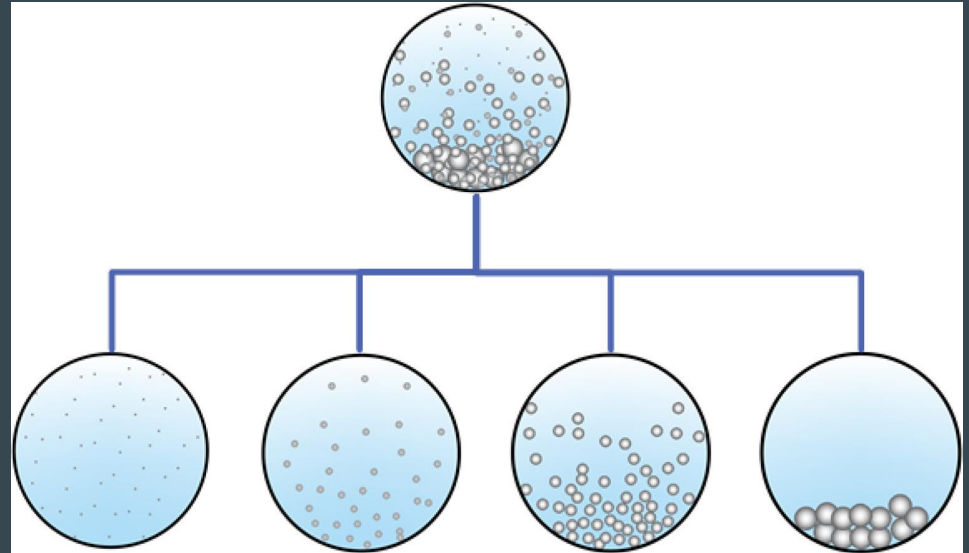

Courtesy of ScienceDirect

Particle size affects resuspension

- Different-sized particles stay suspended in air for different intervals of time and height
 - Small particles stay suspended for longer compared to larger particles
 - Small particles might be lifted to higher heights

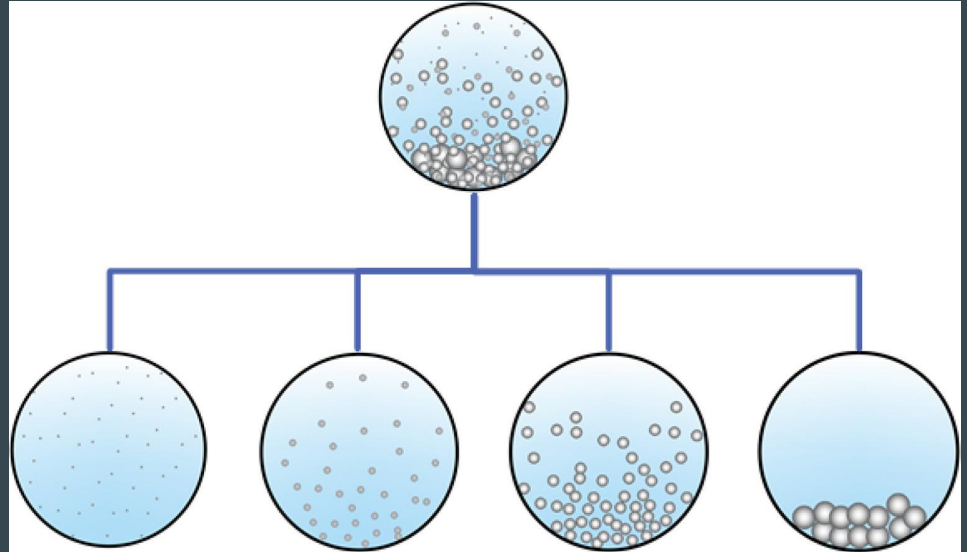

Courtesy of ScienceDirect

- The Plantower estimates particle sizes and concentrations using laser scattering
- Photodiode detects scattered light intensity
- Particle Matter (PM):
 - Cumulative data
 - The Plantower detects particles bigger than a certain size, not particles of exactly that size

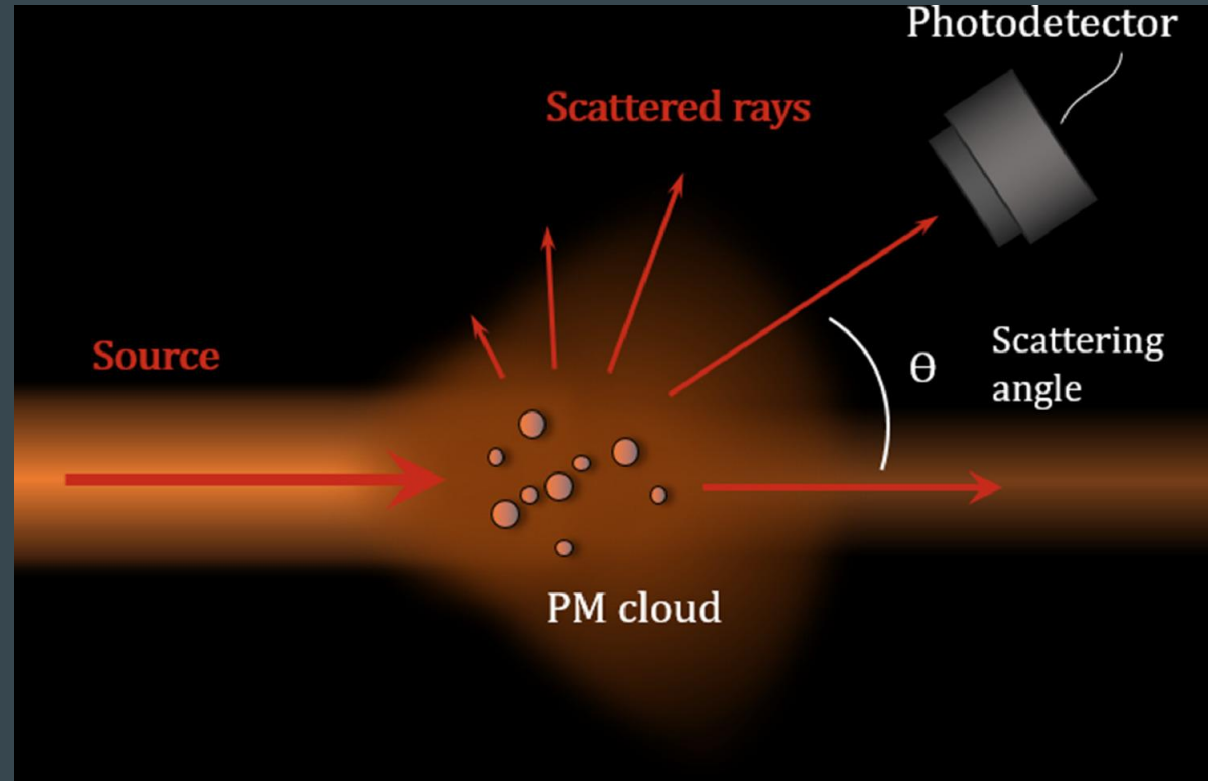

Courtesy of ScienceDirect

Time-Evolution of the Number of Particles of Different Sizes

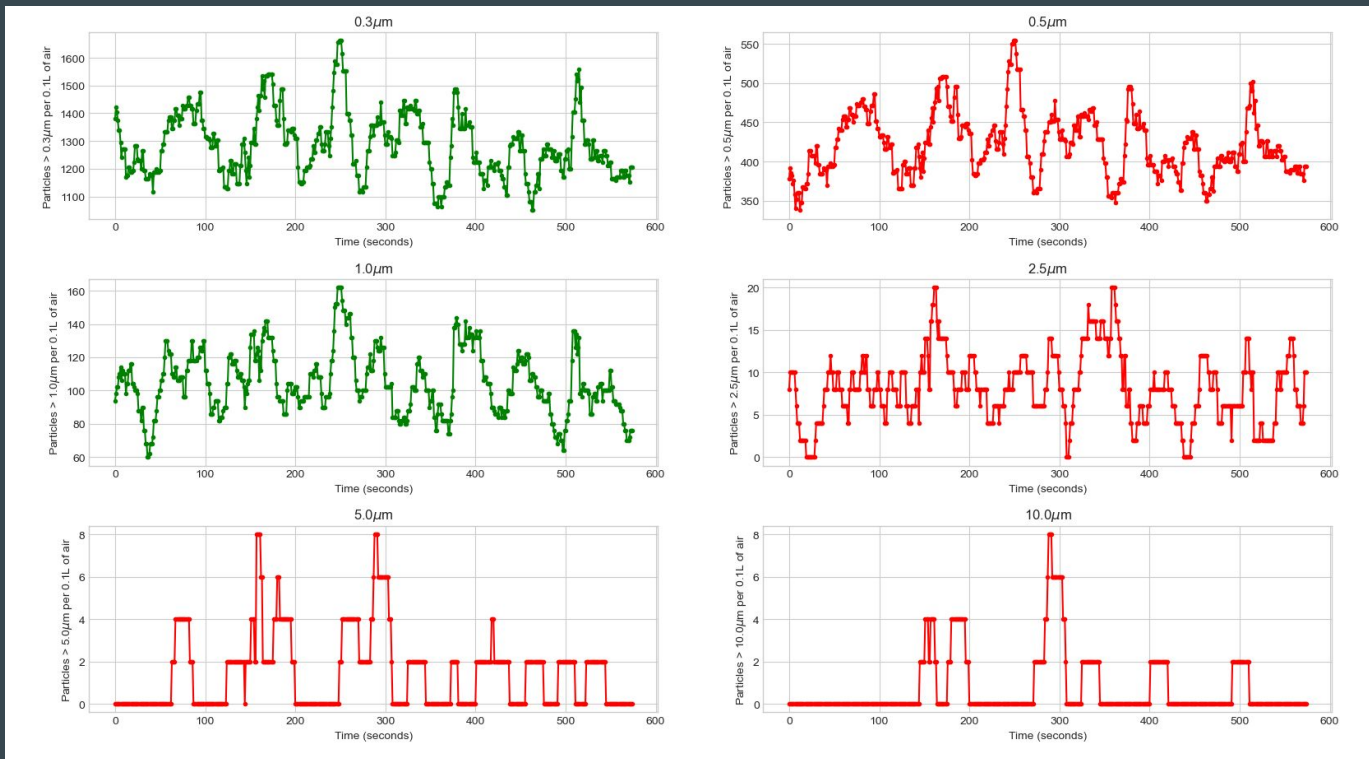

Plantower Data for Different Particle Sizes

Thank you for listening!

Sources

Li et al. “*Effect of interaction of particle with different sizes on particle kinetics in multi-sized slurry transport by pipeline.*” ScienceDirect. Online at www.sciencedirect.com/science/article/abs/pii/S0032591018305862.

Jobert et al. “*Miniature particulate matter counter and analyzer based on lens-free imaging of light scattering signatures with a holed image sensor.*” ScienceDirect. Online at www.sciencedirect.com/science/article/pii/S2666053920300072.