

Effective Lab Oral Reports – Spring 2013

David Hertzog, Eugene V Colla
University of Illinois at Urbana-Champaign



I will present some of my slides and many Phys 403 student slides as examples. We can talk about why they are well constructed examples.

(My remarks about real slides are in these red boxes)

An eye-catching feature on slide 1

This is a technical presentation, so you must develop it as a logical sequence

Sentence title tells what the slide is about ... the rest of the slide supports the assertion

- ✓ ■ What was the goal?
 - ◆ What physics did you address?
 - ◆ What technology?
 - ◆ Define your special vocabulary here
- ✓ ■ What did you actually do?
 - ◆ Apparatus / Procedures / Raw Data
- ✗ ■ What are your results?
 - ◆ Polished graphs, proofs, numerical findings
 - ◆ Principal difficulties and uncertainties
- ✗ ■ Conclusions

Fonts matter

Arial

Comic Sans

Times

Courier

Presentation components and grading scale.

- ✓ Title slide
- ✓ Science introduction
- ✓ Procedure
- ✓ Results. Analysis. Data.
- ✓ Conclusions. Suggestions etc.

CRITERIA		Score
Technical slides	(15)	
Science accuracy	(15)	
Quality of oral delivery and sharing of effort	(15)	
Got essential points across of effort	(15)	
Overall impression	(15)	
Final Totals	(75)	

Title

OPTICAL STUDY OF FERROELECTRIC POTASSIUM DIDEUTERIUM PHOSPHATE (DKDP)

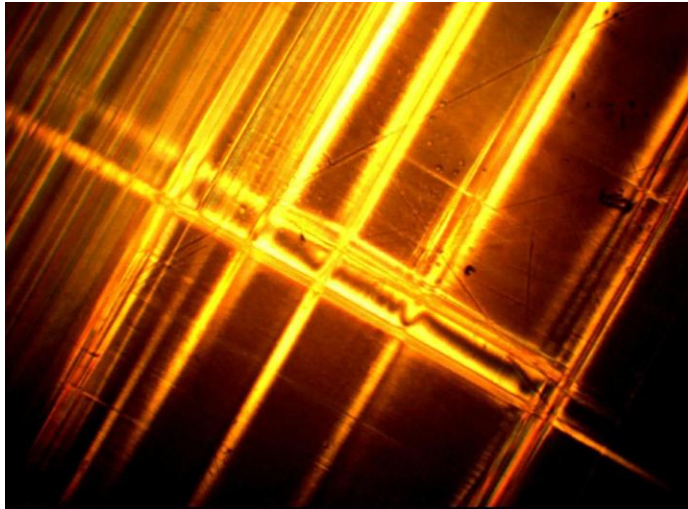

Author name

Student name

2/19/13

Date

Physics 403, Spring 2013
University of Illinois at Urbana-Champaign

Affiliation

Phase transition of Helium 4

- Below $T_\lambda = 2.17$ K, helium exists in mixture of superfluid and normal liquid helium.

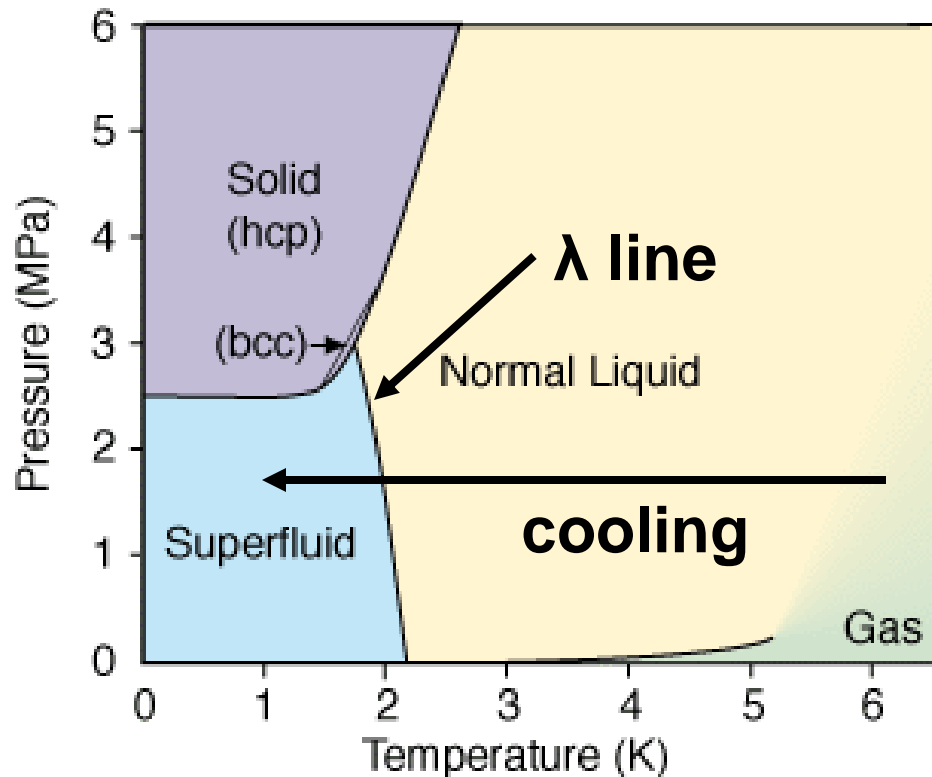

The muon lifetime leads to the most precise determination of the Fermi constant, and gives the weak interaction strength

- The relation is

measure this \rightarrow $\frac{1}{\tau} \propto G_F^2 (1 + \delta)$

- *MuLan* aims to determine τ_μ to 1 part per million precision, which requires:
 - ◆ 10^{12} muon decays
 - ◆ A muon beam of several MHz
 - ◆ A time-structured (chopped) beam
- I spent most of the summer running this experiment

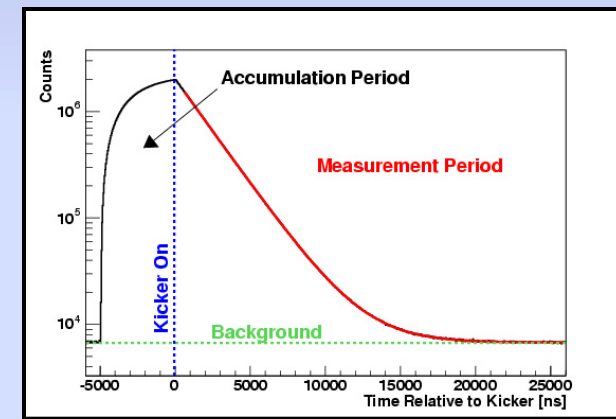

What happen if they are struck by pulses ?

A pulse or a series of pulses is used to change the net magnetization of system. Pulsed NMR!

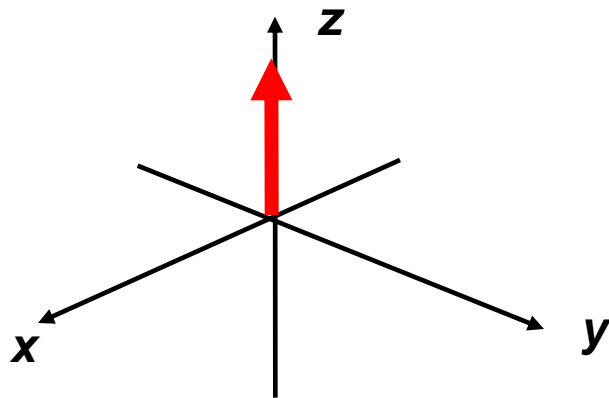

90° Pulse

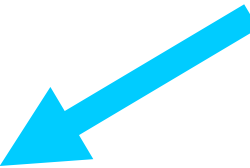
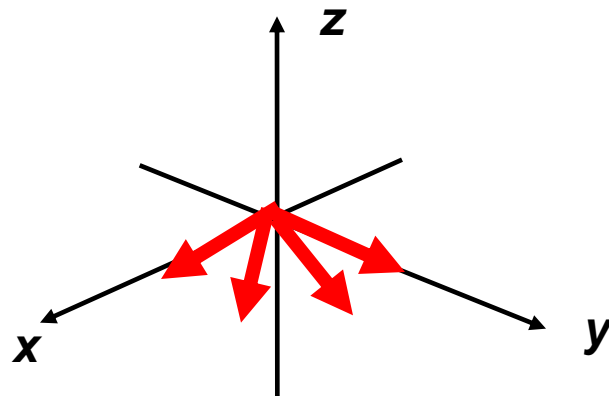
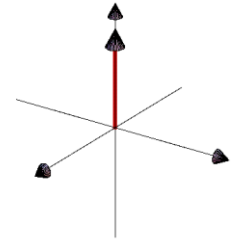
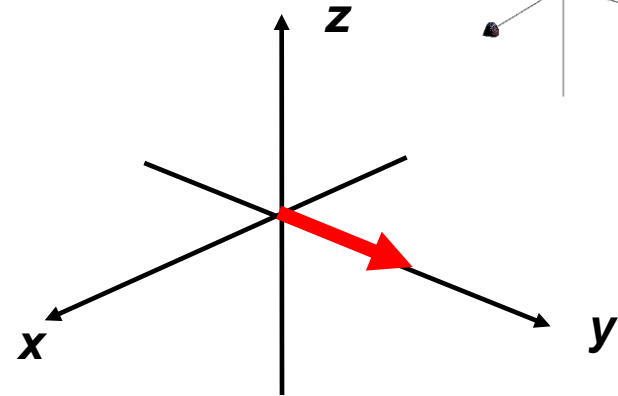

?

$$M(t) = M_0 e^{-\frac{t}{T_2}}$$

What happens to a nucleus in a magnetic field ?

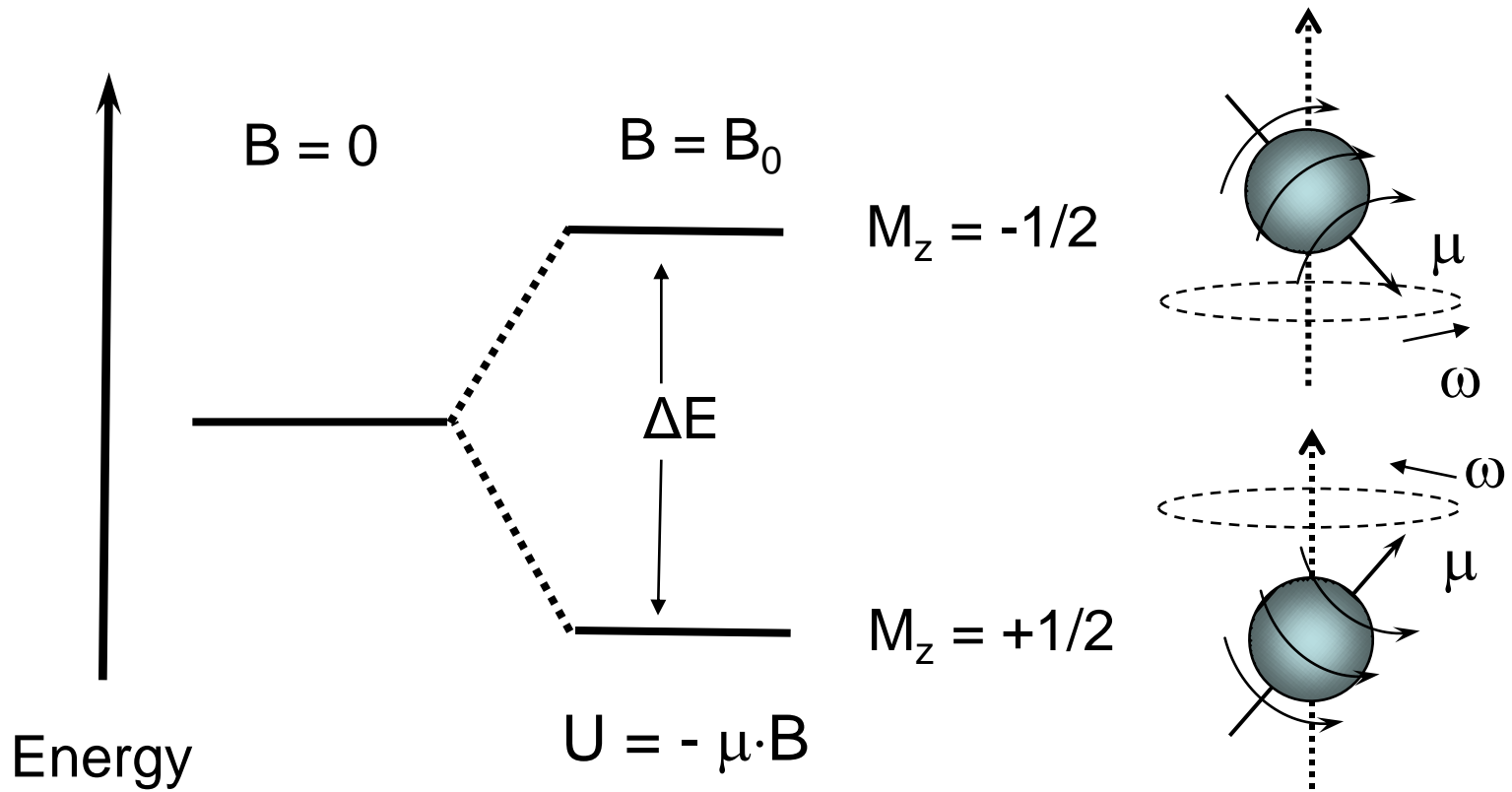

(Courtesy of Bishop. K)

$$\Delta E = \gamma \cdot \hbar \cdot B_0 = \hbar \omega_0 \rightarrow \text{Larmor frequency!}$$

Phase Transition in BaTiO₃

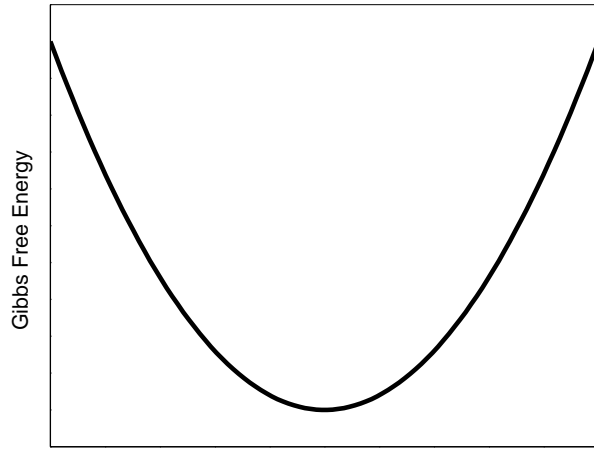

Polarization

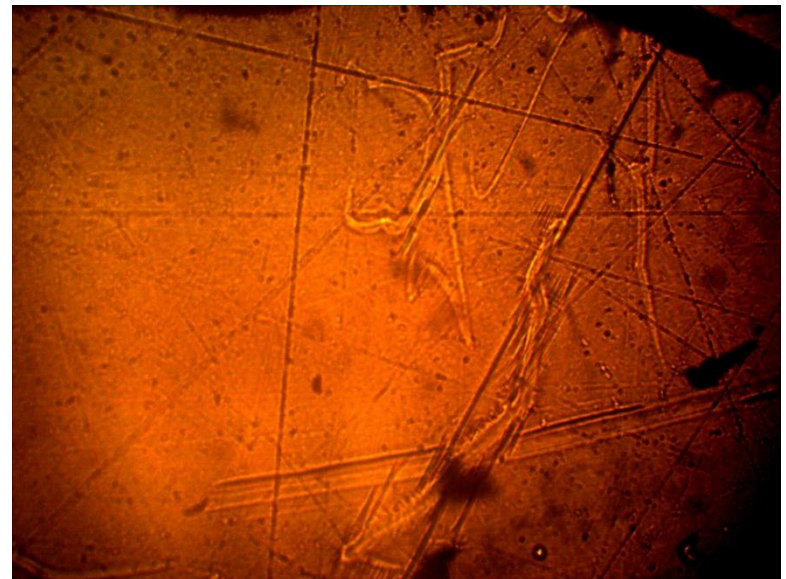
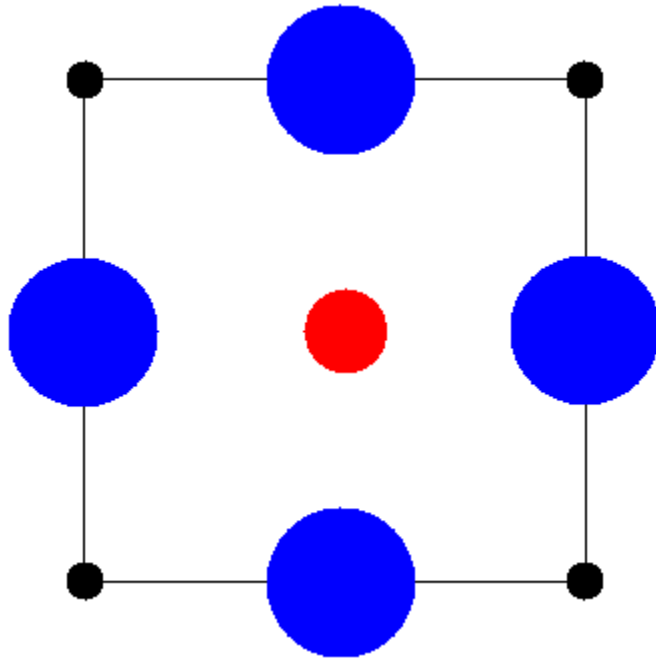
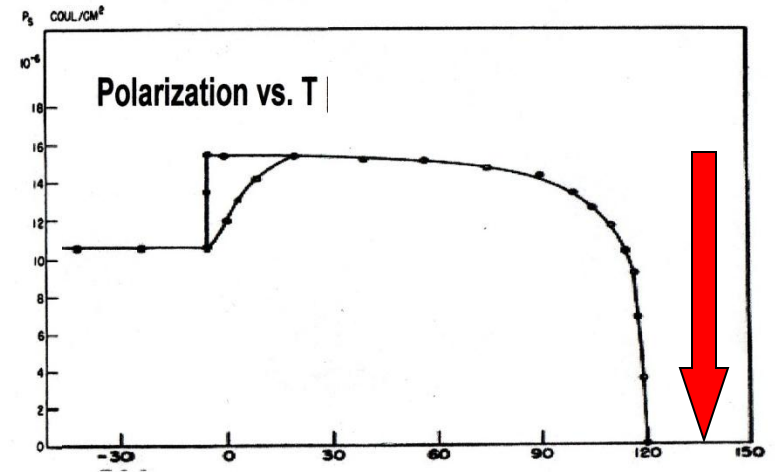

Phase Transition in BaTiO₃

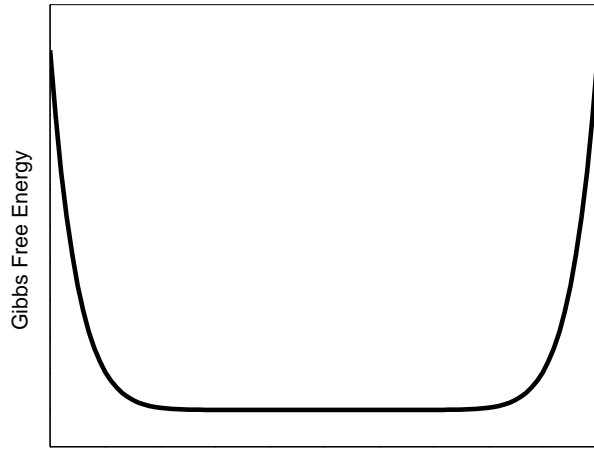

Polarization

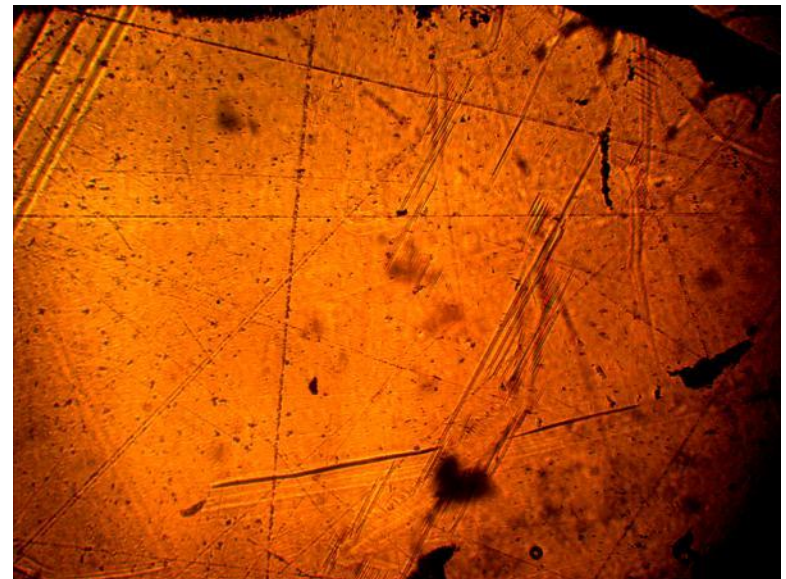
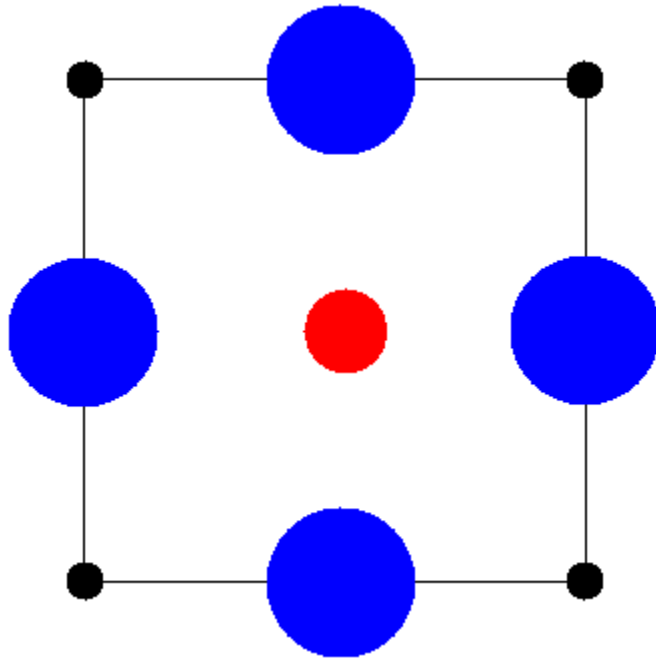
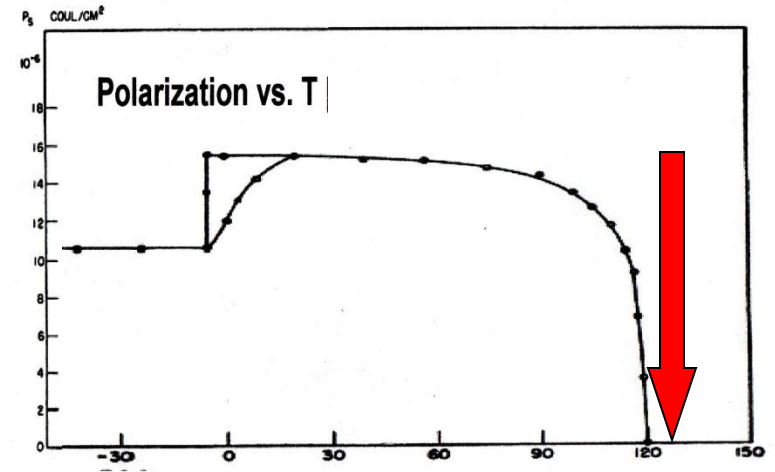

Phase Transition in BaTiO₃

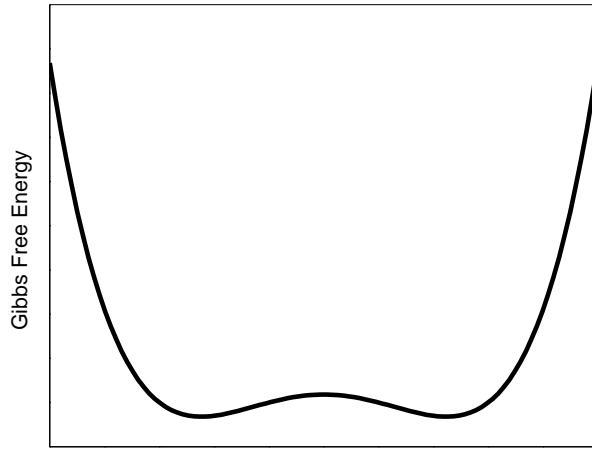

Polarization

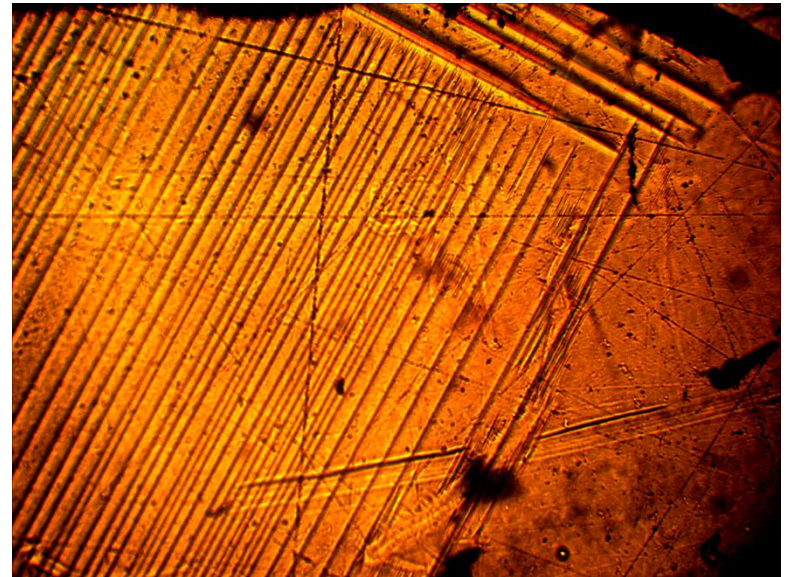
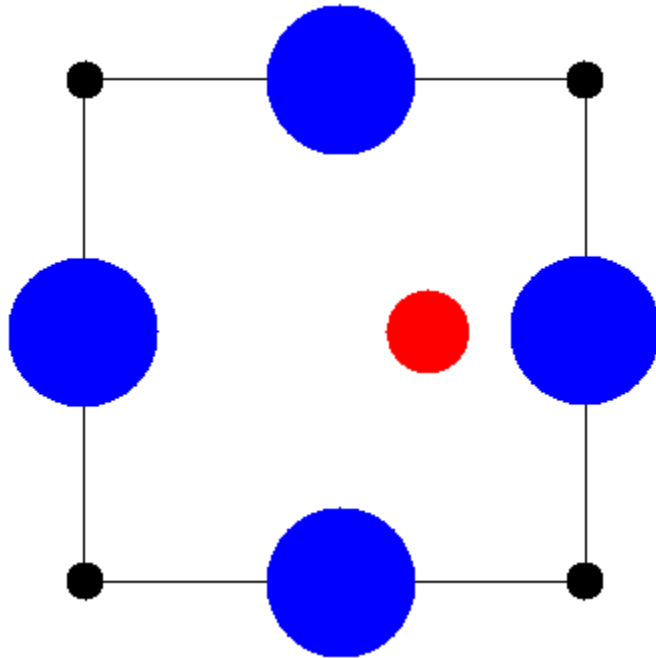
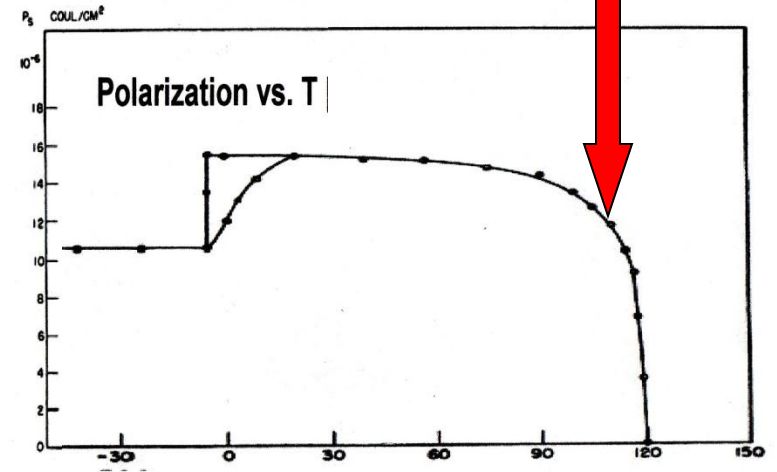

Phase Transition in BaTiO₃

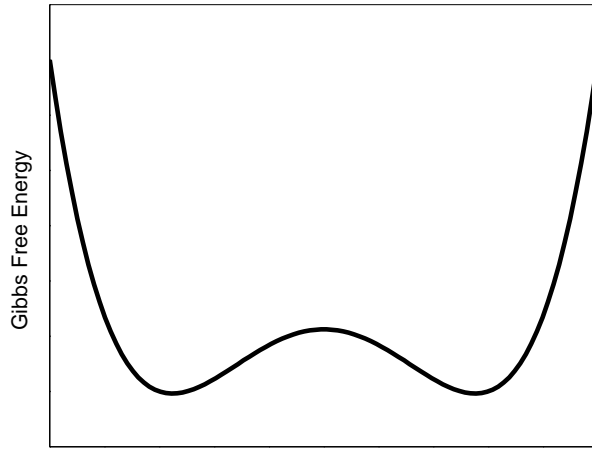

Polarization

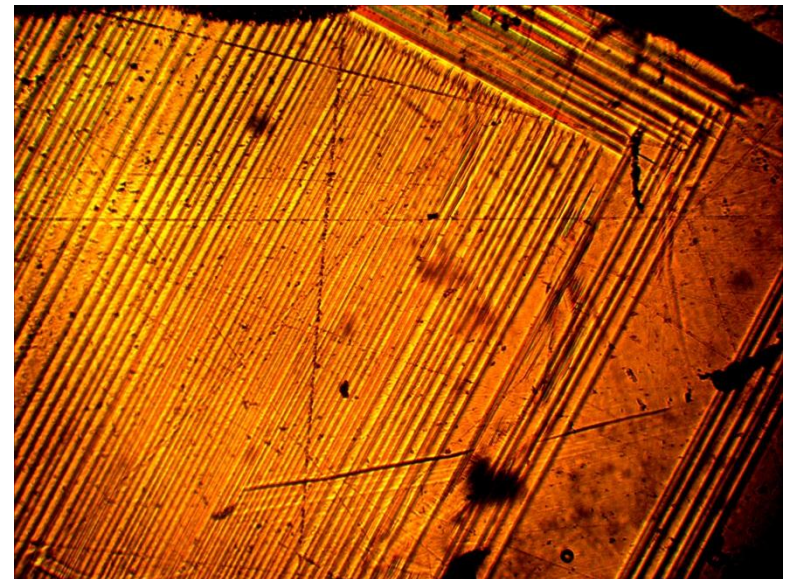
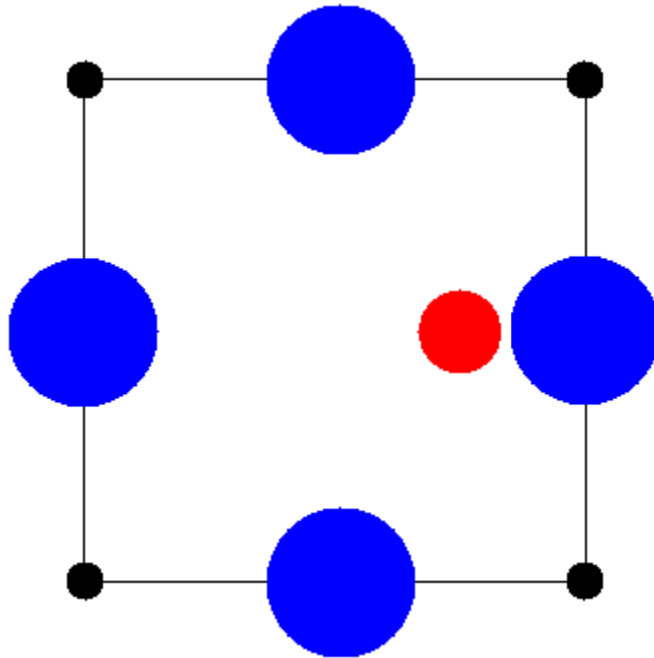
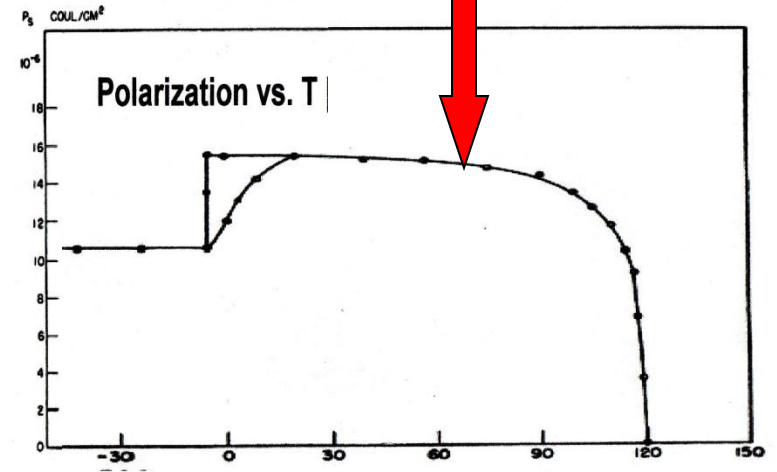

ASIDE: Keep equations selective and informative

- What can an audience grasp in 'real time'?
 - ◆ If they already know it, then they know it
 - ◆ If they don't know it, they usually have to study it term by term
- Take a sparse approach
 - ◆ Substitute proportionalities for equalities ?
 - Can eliminates uninteresting constants
 - Can emphasize relationship of variables
 - ◆ Substitute words for blocks of standard terms?

$$\frac{1}{\tau} = \frac{G_F^2 m_\mu^5}{192\pi^3} (1 + \delta)$$
$$\frac{1}{\tau} \propto G_F^2 (1 + \delta)$$

$$\Gamma \propto (\text{phase space}) \times M_{ij}$$

Set them off attractively

- ◆ Use builds and arrows to walk audience thru (see example)

Excitation and fluorescence signal convoluted together

observed signal → $F(t) \propto \int_0^t E(t') F_\delta(t-t') dt'$

excitation signal

simple fluorescence response (exponential)

- Excitation as sinusoid is simplest:

$$E(t) = E_0 + 2E_1 \cos(\omega t)$$

- Generalized through Fourier analysis
 - All periodic function can be expanded as sum of sinusoids

Show the equipment IF it helps explain your steps – not because you love it

- **Photographs give scale and reality – but you add labels**
- **Schematics provide concept**
- **Icons strip away unnecessary details**
- **All of these techniques can be useful**

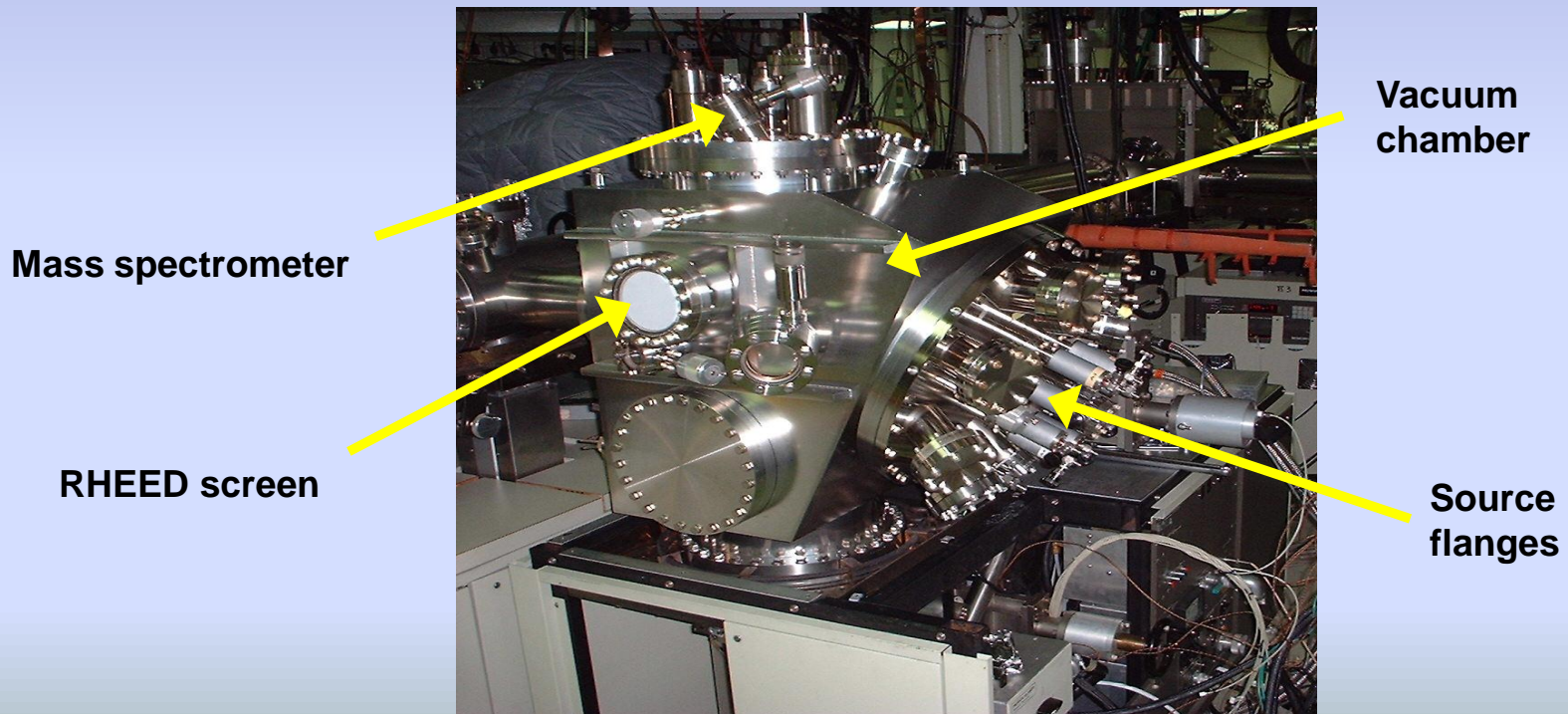

Everybody loves an optical bench, but unless you map out the elements and the beam paths, it doesn't mean much

Experimental Apparatus

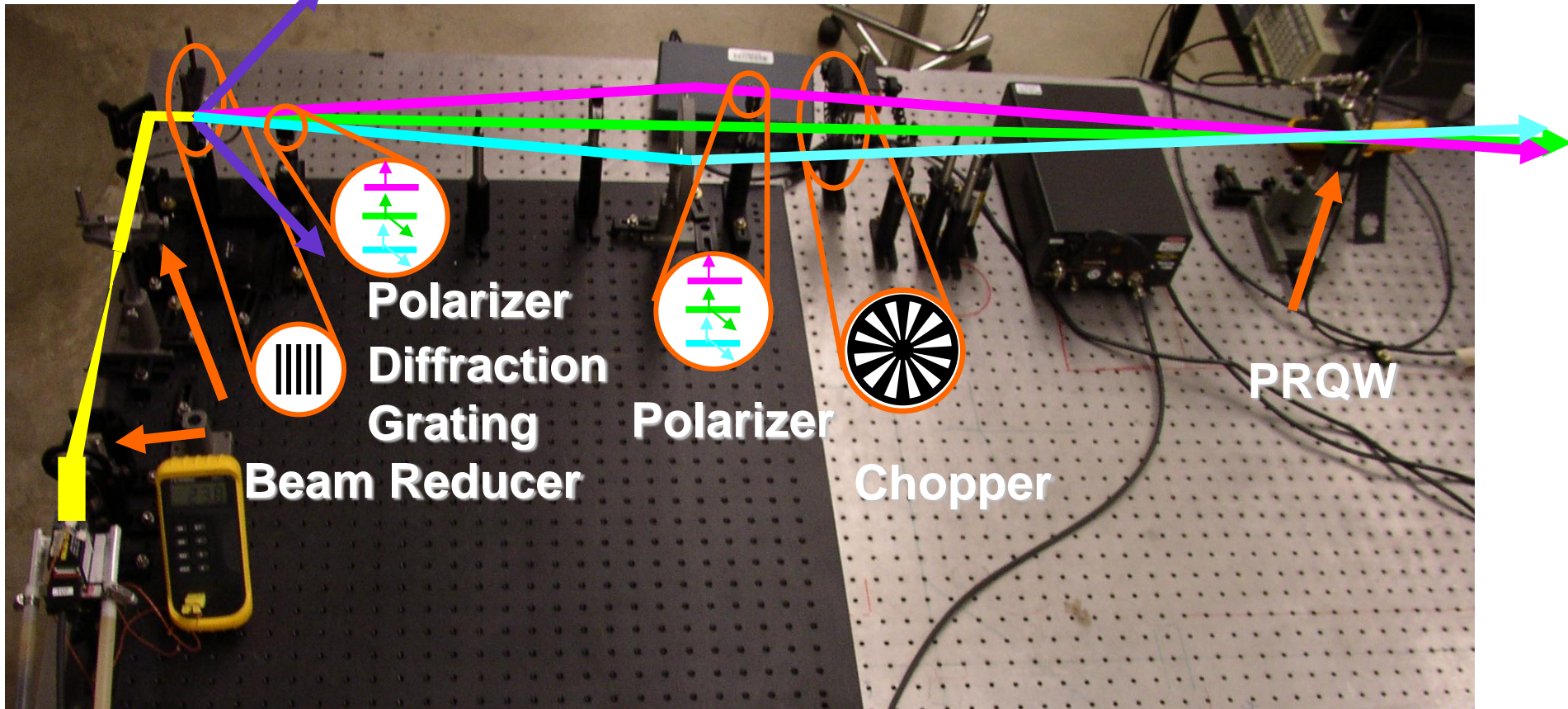

Setup diagrams, apparatus, measuring idea...

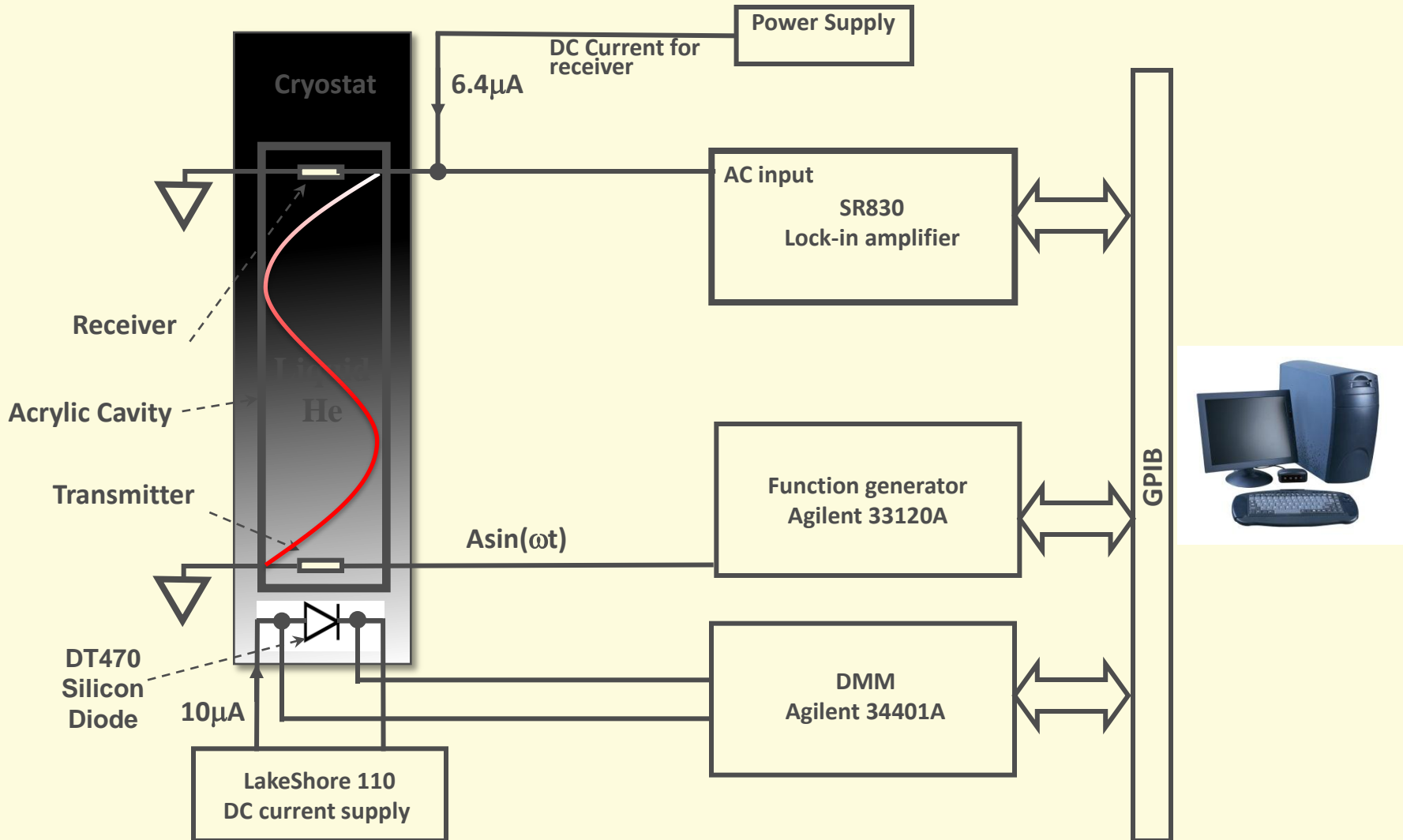

Samples: preparation, configuration etc.

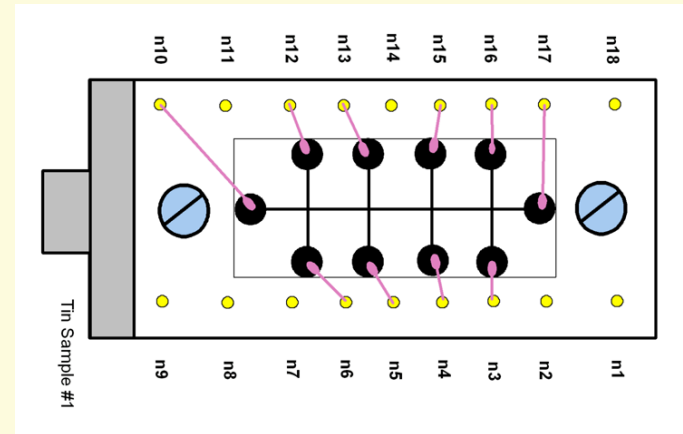
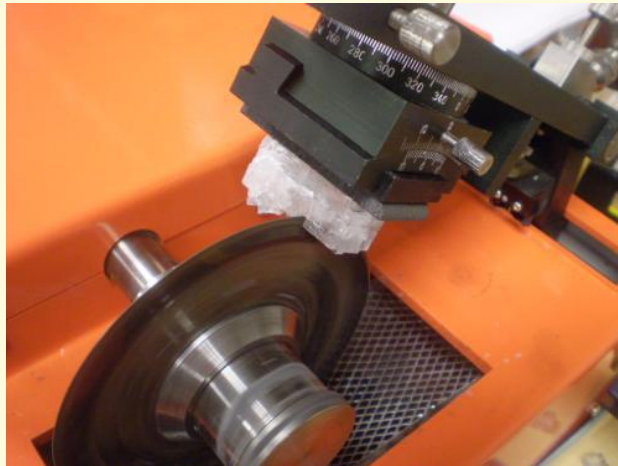
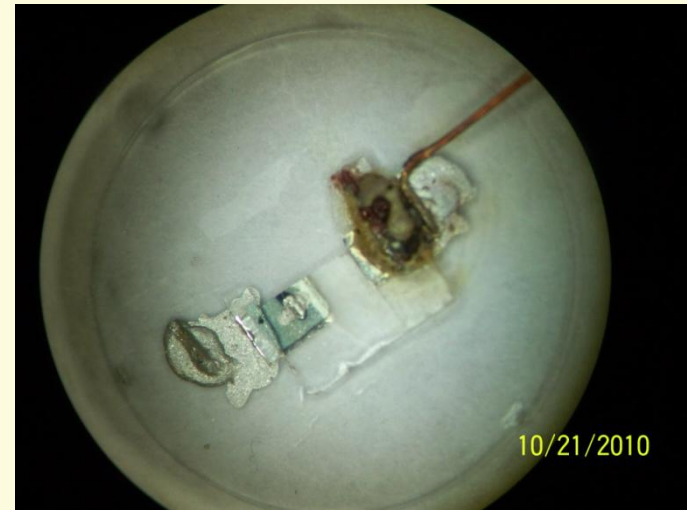
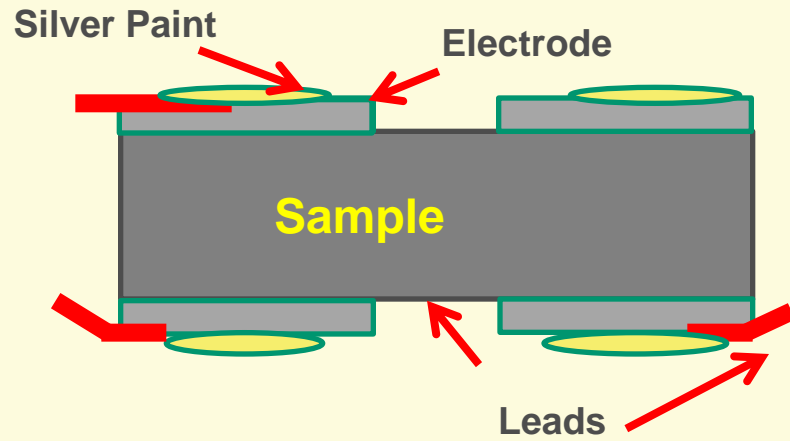

Setup of Source and Detectors

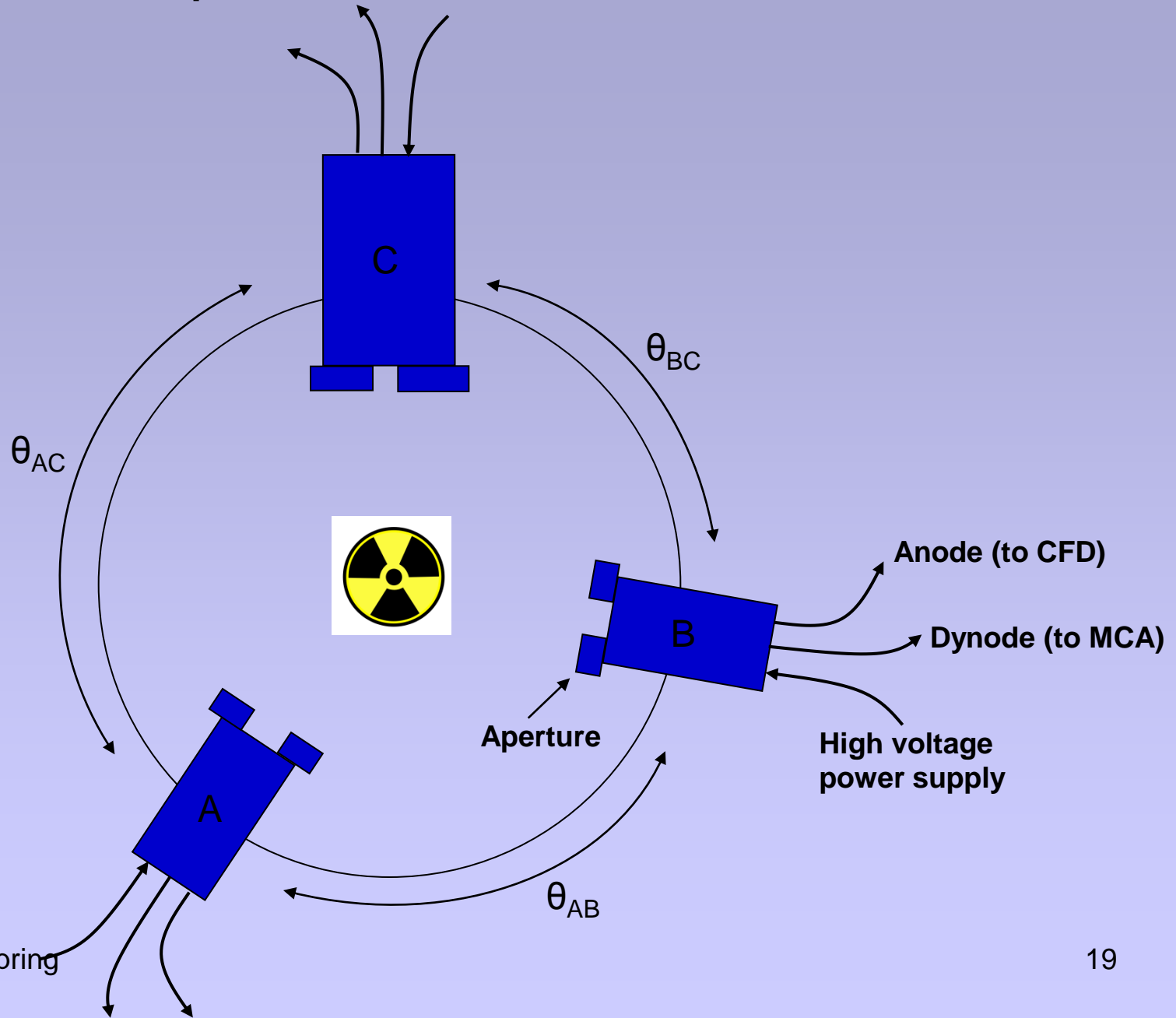

Results

Raw tunneling data

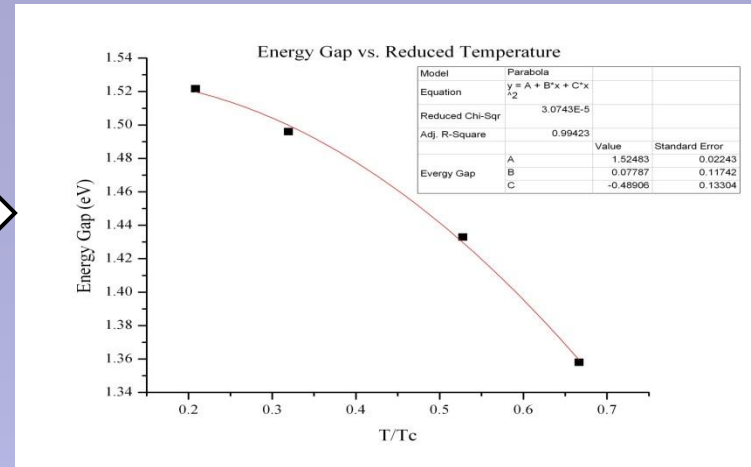
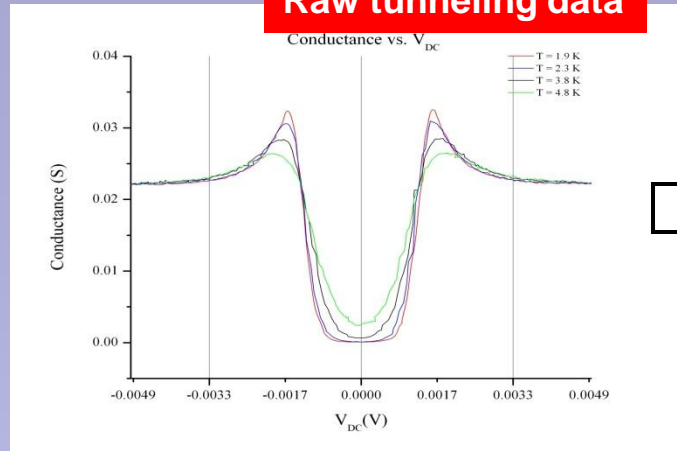

Energy gap derived from tunneling conductivity

Count Rate vs. Pressure (Argon)

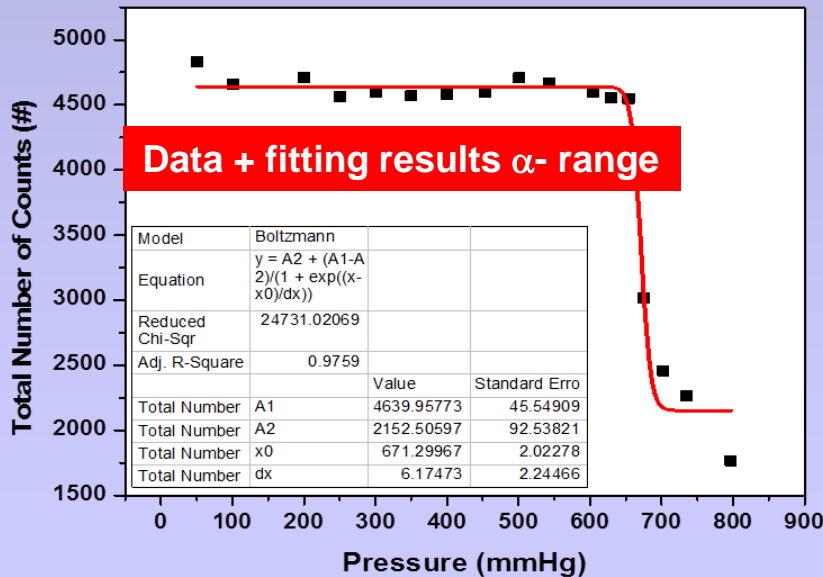

Data + fitting results fluorescence

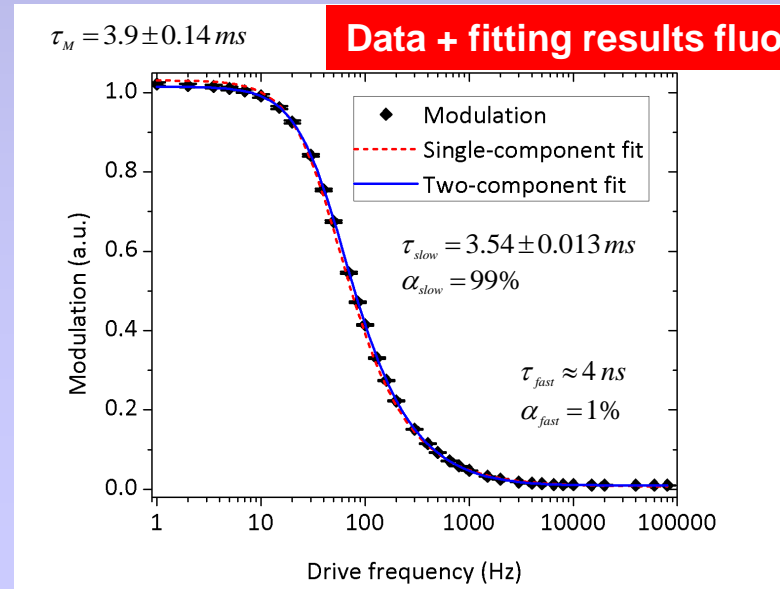

Results – witnessing a mystery?

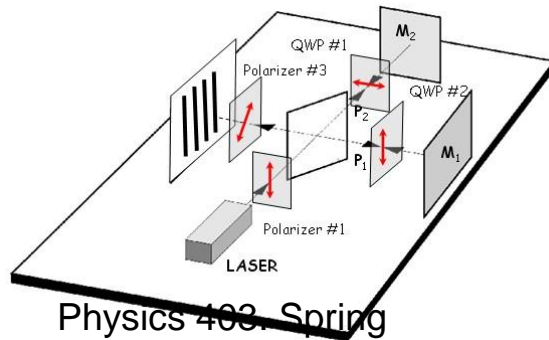
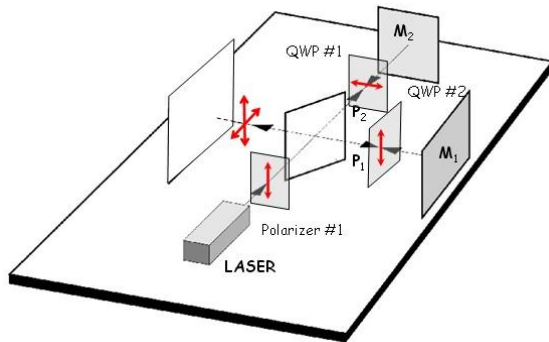
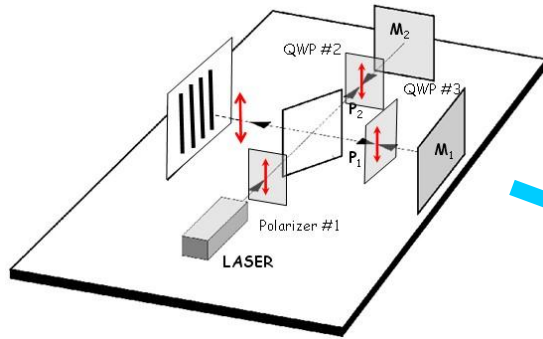

Presenting data is your most important and challenging task

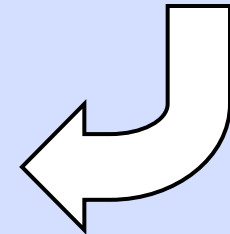
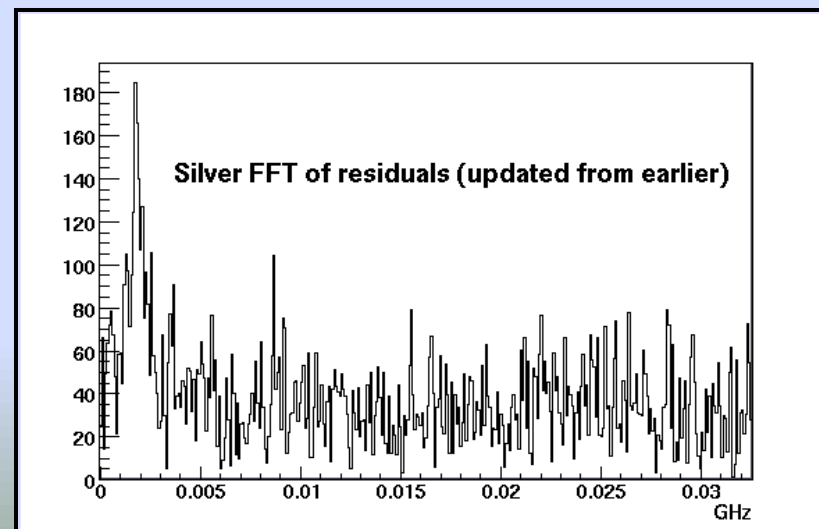
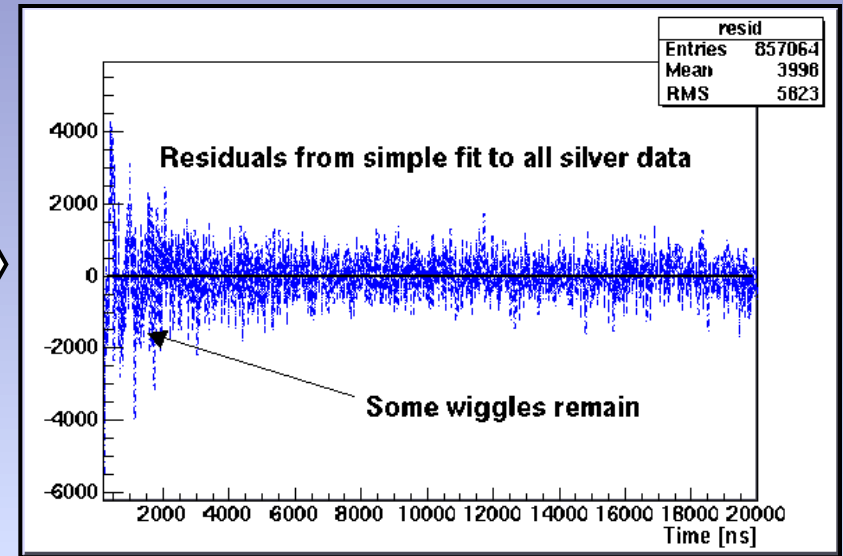
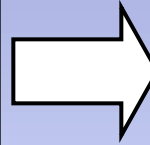
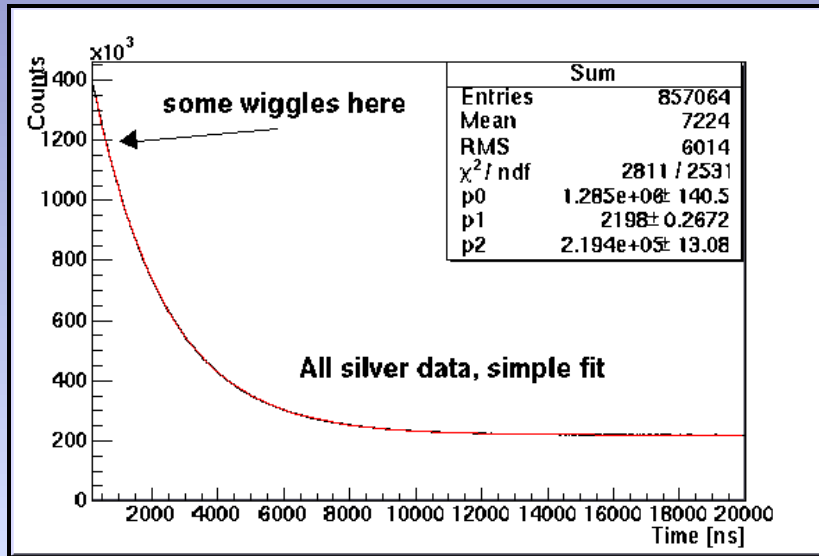

A fit to the Curie-Weiss law shows a shift in T_C

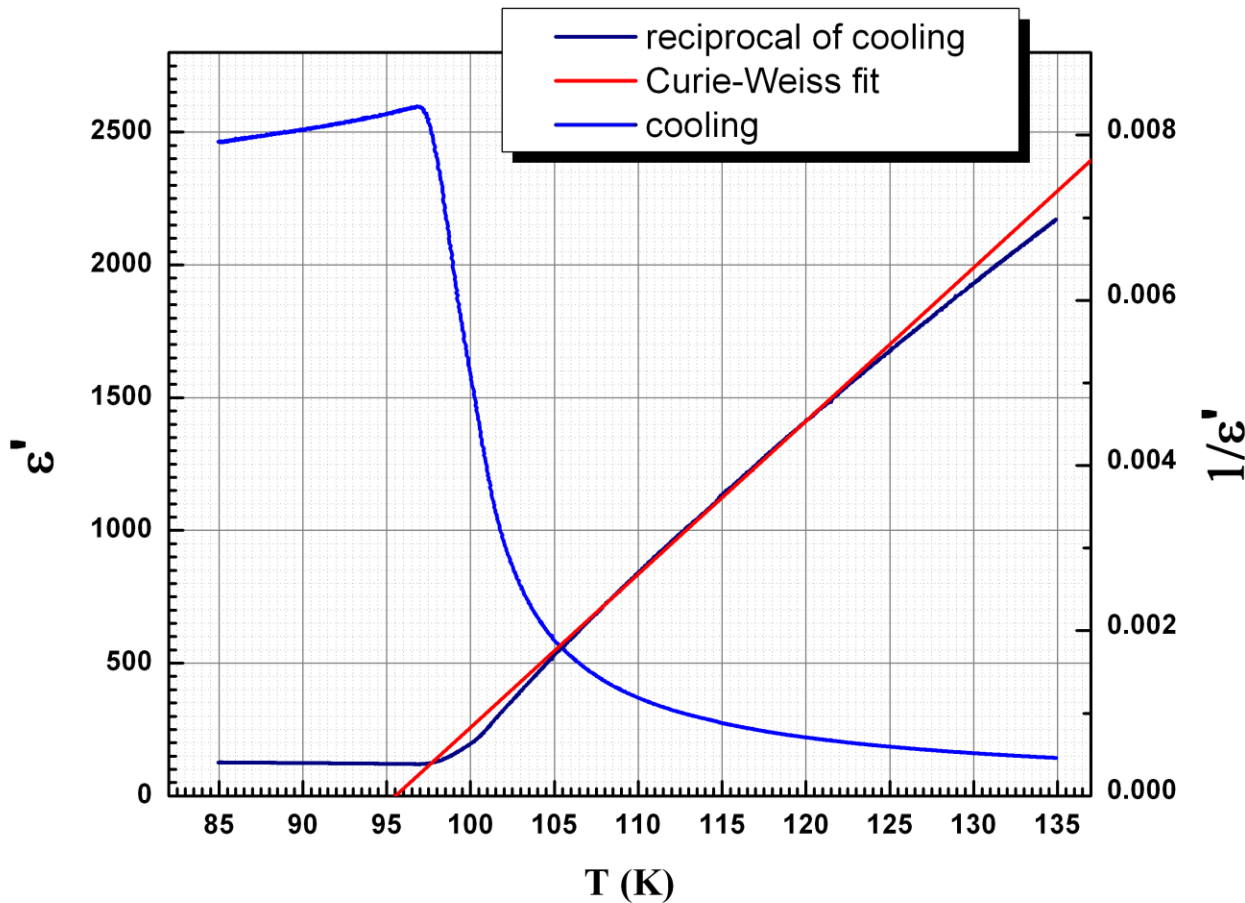

$$\epsilon' = \frac{C}{T - T_C}$$

$$C = 5.4 \times 10^3 \text{ K}$$

$$T_C = 95 \text{ K}$$

Some more examples of data, where images are important

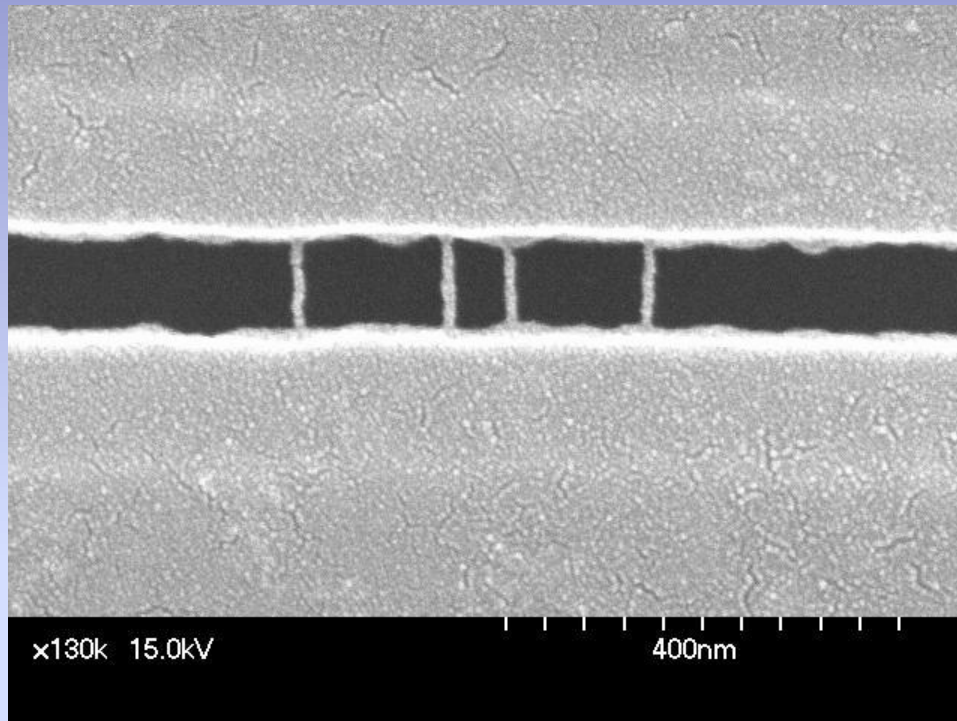

10 nm wires: AuPd on DNA

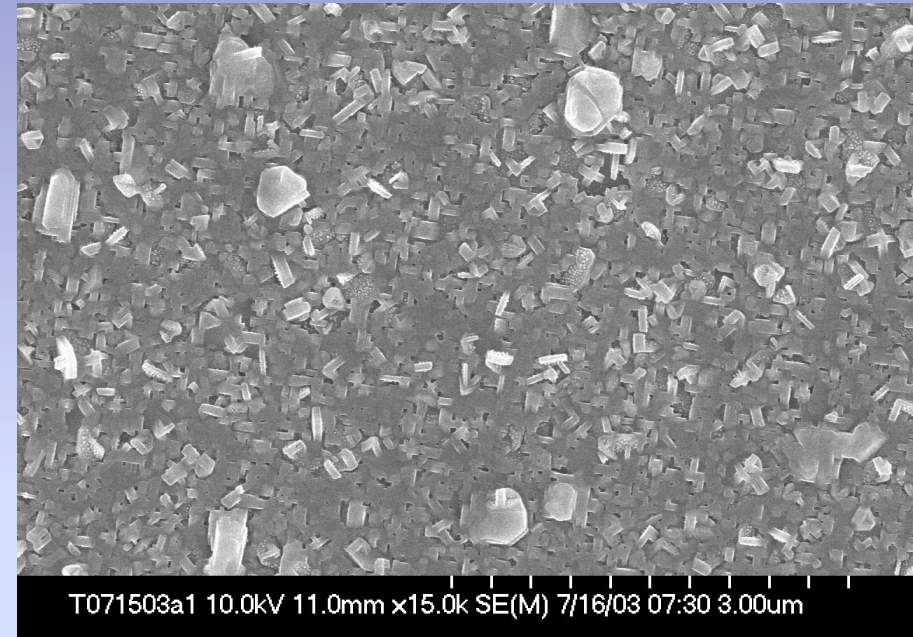

AFM of Optical Data Storage Media

CD

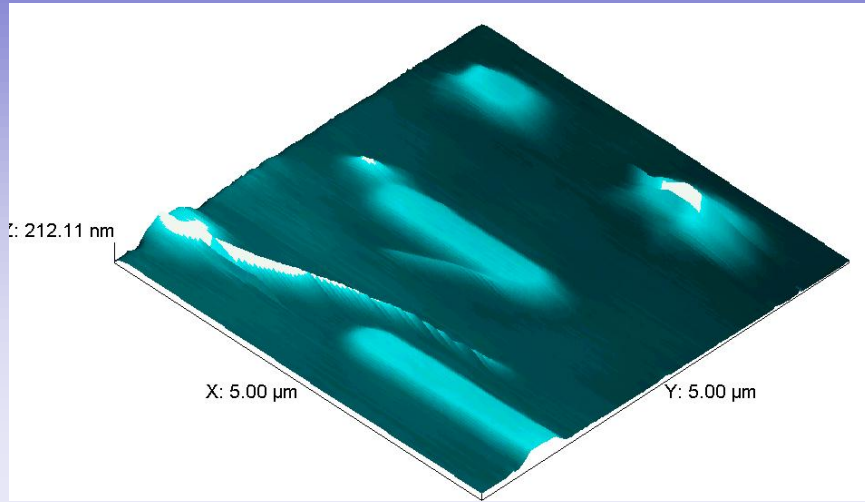

DVD

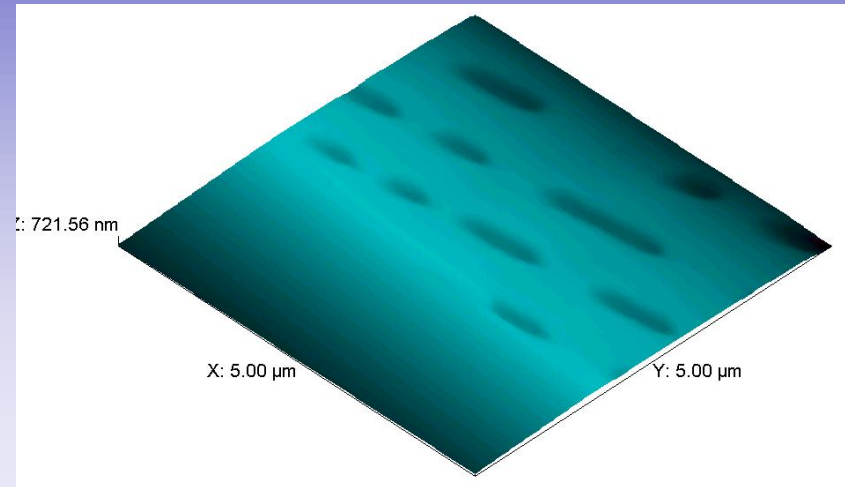

Blu-Ray

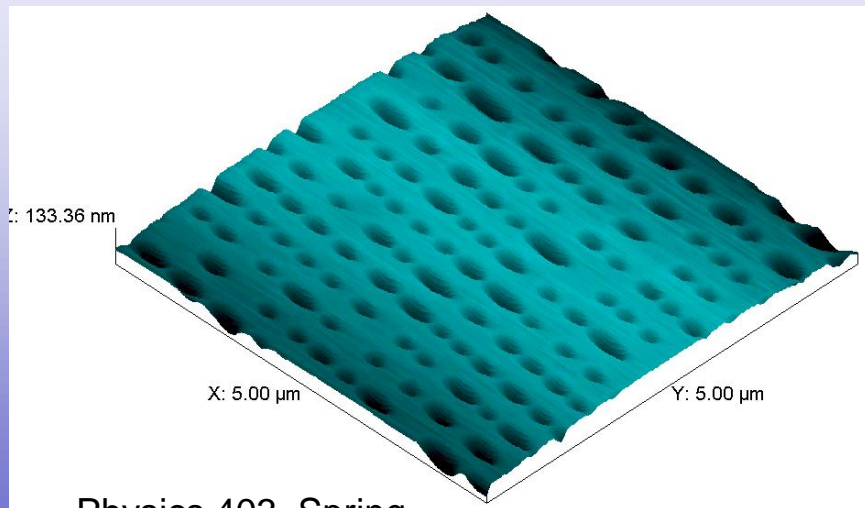

	CD	DVD	Blu-Ray
Mark length	0.99 - 2.96	0.48 - 1.45	0.14 - 0.41
Track pitch	1.63	1.00	0.40
Track width	0.50	0.24	0.15

Units in μm

$$V = C \sqrt{\left(\frac{T - T_{offset}}{T_\lambda}\right) \left(1 - \left(\frac{T - T_{offset}}{T_\lambda}\right)^{5.6}\right)}$$

Offset, intrinsic to the experiment

$$C \approx 26$$

$$T_\lambda \approx 2.17$$

$$V = C \left[\left(\frac{T - T_{offset}}{T_\lambda}\right) \left(1 - \left(\frac{T - T_{offset}}{T_\lambda}\right)^\beta\right)^\gamma \right]$$

Fit to the exponents as well

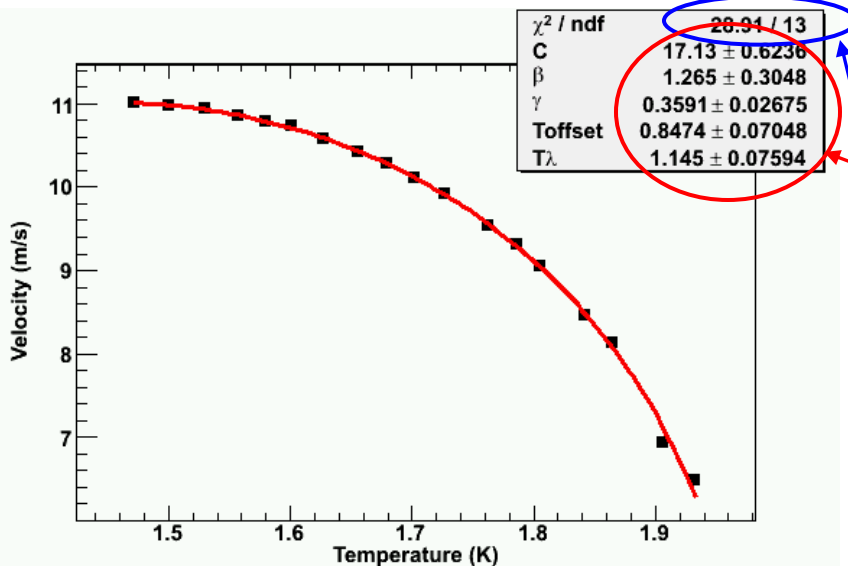

Perform the 5 parameter fit-

The values that are obtained are not very close to the expected values

Also, the fit is not the best

Try to fit the data with this function

$$V = \left(1 - \frac{T - T_{\text{offset}}}{T_{\lambda}} \right)^{\gamma}$$

The data refuses to fit to this function

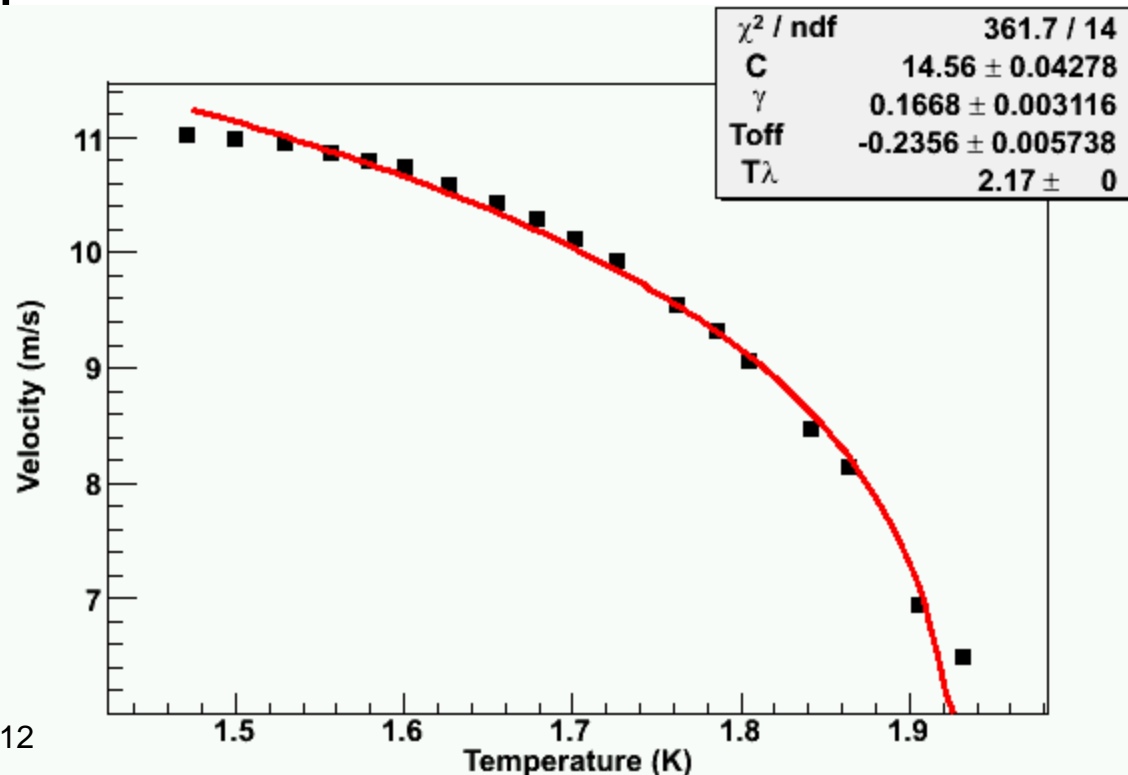

Finish your talk with the data analysis and conclusions and a slide showing the main points you want us to remember

- ◆ **Make sure you discuss the principal uncertainties.**
 - *For most of these experiments, it will be how accurately does your instrument measure something*
 - *A few experiments will also have statistical uncertainties ... more data leading to a better finding*
- ◆ **Include a representative (simplified) graphic**
 - *This slide will be up during question period so this graphic will get burned into people's memory*
- ◆ **Because this is a lab, offer some advice for others who follow**

