



# Written Reports

***D. Hertzog, E. Colla***

**Phys 403, Fall 2012**

# The report has 5 main components

## ■ Abstract

- A concise summary of **what, why, how**, and **what** you found out in about 4 – 5 sentences at most. **No details of the experiment and data analysis**

## ■ Science:

- Background information and context but **not a long historical excursion**
- Motivation and what you are trying to learn
- Physics diagrams, energy levels, phase conventions, etc. depending on the experiment

## ■ Procedure.

- What you did as “steps” and how you did it
- Electronics, topology, layout diagrams,
- Perhaps scope shots if appropriate,
- Photo if it helps but not a picture gallery
- Perhaps tables of raw data

## ■ Results & Analysis.

- The conversion of raw data into a physics result.
- Plotting and data fitting,
- Interpretation of fits and data
- Physics conclusions
- Discussion of uncertainties

## ■ Conclusions

- Concise summary of what you did and what you found out. This is not a long section

# Title / Abstract

## Measurement of $T_1$ and $T_2$ Relaxation Times in Epoxy using PNMR

An excellent student

University of Illinois at Urbana-Champaign

9 February 2009

### ABSTRACT

In this experiment, traditional PNMR techniques were used to study the relaxation times of an epoxy sample (Miller-Stephenson Epoxy 907) as it cured, with the aim of thus elucidating the reaction characteristics between its source reagents. It was discovered that  $T_1$  increased while  $T_2$  decreased with curing time. Consequently, it can be concluded that the curing process results in the formation of a rigid molecular structure, is exothermic, and proceeds at an approximately uniform rate.

# Introduction / Science

## INTRODUCTION<sup>1,2</sup>

Continuous-Wave Nuclear Magnetic Resonance (CWNMR) was discovered by Edward Purcell and Felix Bloch in 1946, for which they were awarded the Nobel Prize in Physics in 1952. From the principles laid down by Purcell and Bloch for CWNMR, techniques such as Magnetic Resonance Imaging (MRI) have been developed. The technique of Pulse NMR (PNMR) used in this experiment was developed by Erwin Hahn in 1950.

### Scientific Basis

The basis of both forms of NMR is the intrinsic magnetic moment  $\vec{\mu}$  of the nucleus. Semi-classically, this is tied to the nucleus' angular momentum  $\vec{L}$  and gyromagnetic ratio  $\gamma$  by the equation

$$\vec{\mu} = \gamma \vec{L} \quad (1.1)$$

In a magnetic field  $\vec{B}_0$ , the nucleus will experience a potential given by

$$\begin{aligned} U &= -\vec{\mu} \cdot \vec{B}_0 \\ U &= -\gamma \vec{L} \cdot \vec{B}_0 \end{aligned} \quad (1.2)$$

If we define  $\vec{B}_0 = B_0 \hat{z}$ , we see that

$$\begin{aligned} U &= -\gamma L_z B_0 \\ U &= -\gamma m \hbar B_0 \end{aligned} \quad (1.3)$$

where  $m$  is the magnetic quantum number.

Thus, for nuclei with spin  $\frac{1}{2}$ ,  $m = \pm \frac{1}{2}$  and we see the splitting of nuclear energy levels within the sample, with

# Introduction / Science

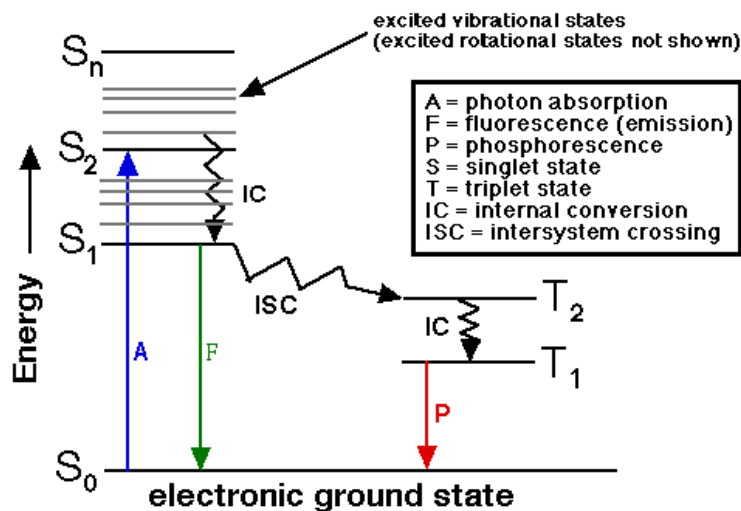

Figure 1. An electron's excitation and de-excitation can be seen to travel through different energy states, including spin singlet states and triplet states. The difference between the singlet and triplet states comes from the different interactions between the parallel and anti-parallel spins of the electron.

# Procedures ...

## Calibration

Due to environmental factors such as temperature changes, the field supplied by the permanent magnet is not constant. Consequently, the resonant frequency will be affected (see Eqn. 1.4) and must be adjusted periodically to reflect this. To facilitate such adjustments, the Mixer unit multiplies the precession signal from the sample and the input signal from the oscillator, producing an output signal that will exhibit beating should the frequencies of the two input signals not match (Fig. 1a.). Tuning was done by adjusting the oscillator frequency until the beating effect disappeared (Fig. 1b.). It is suggested by the accompanying literature that tuning should be done ~every 15min; over the course of the experiment, it was noticed that the permanent magnetic field does indeed show appreciable changes over such a span of time.

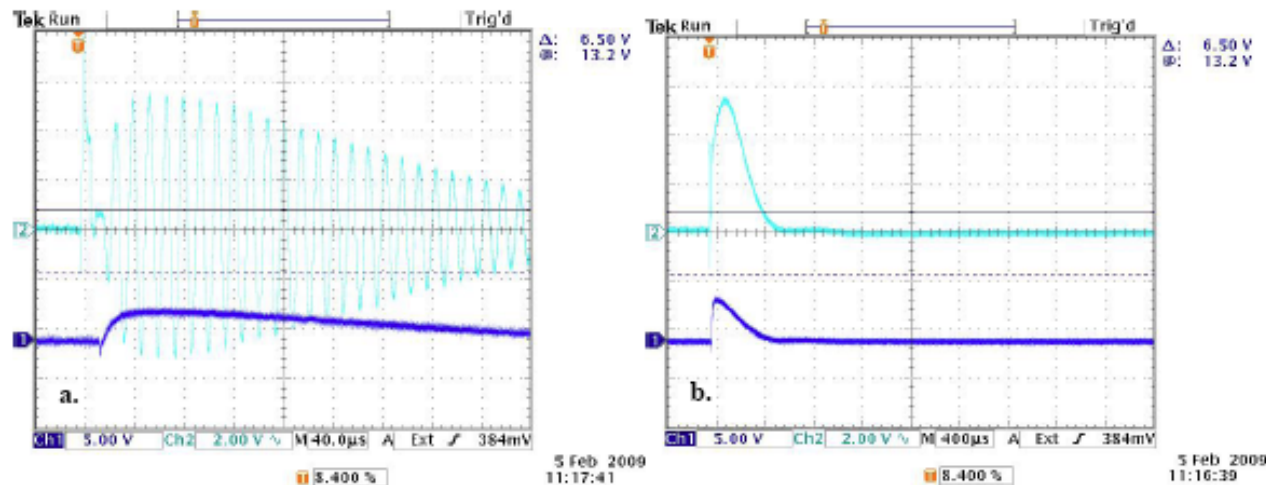
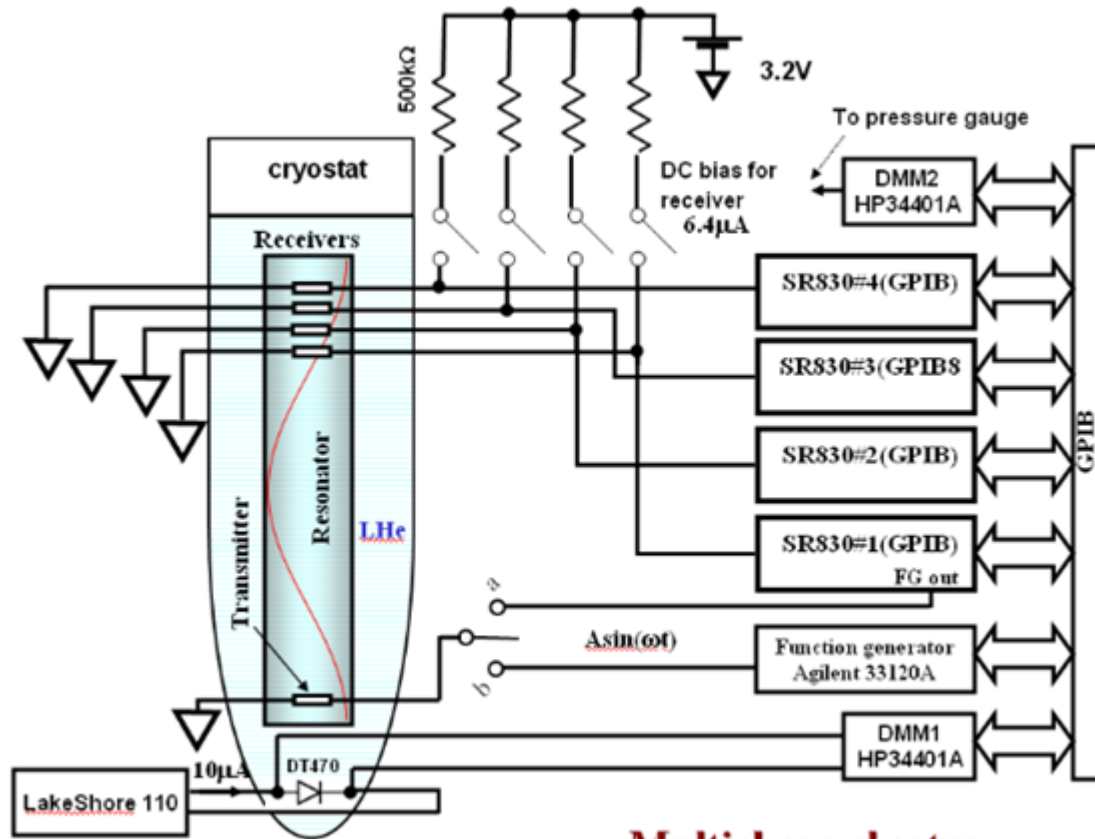

Figure 1. Example of a mixer signal (light blue trace) a. with beating; b. without beating. Thus, the oscillator is tuned to the resonant frequency in b.; the trace in dark blue is the precession signal.

# Procedures ...



**Multichannel setup**

**Setup diagram**

# Procedures ...

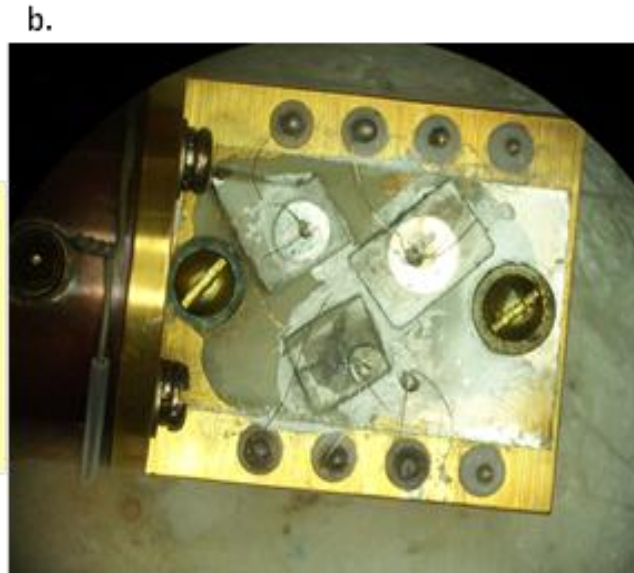
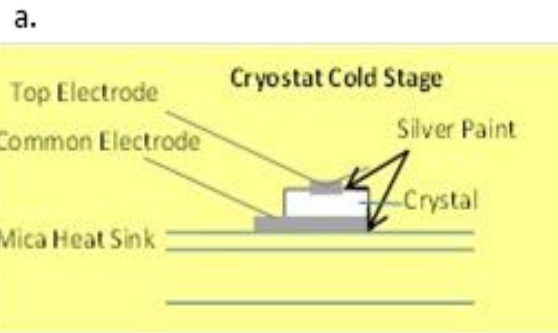

**Samples, sample preparation**

# Analysis ...

Glycerin added (g)	Approximate percentage of glycerin by weight	water added (g)	Final percentage of glycerin by weight
3.517	100	0	100
9.959	97.5	0.255	97.5
5.76	95	0.288	95.2
1.816	90	0.245	88.1
3.500	80	0.876	80.0
3.512	70	1.495	70.1
3.525	60	2.357	58.2
3.514	40	5.298	40.0
3.525	20	14.33	19.7

Table 1. The glycerin concentration of the prepared sample and the amount of glycerin and water added to the sample.

**Data collected in table**

# Analysis ...

## Magnetic Field in XY plane

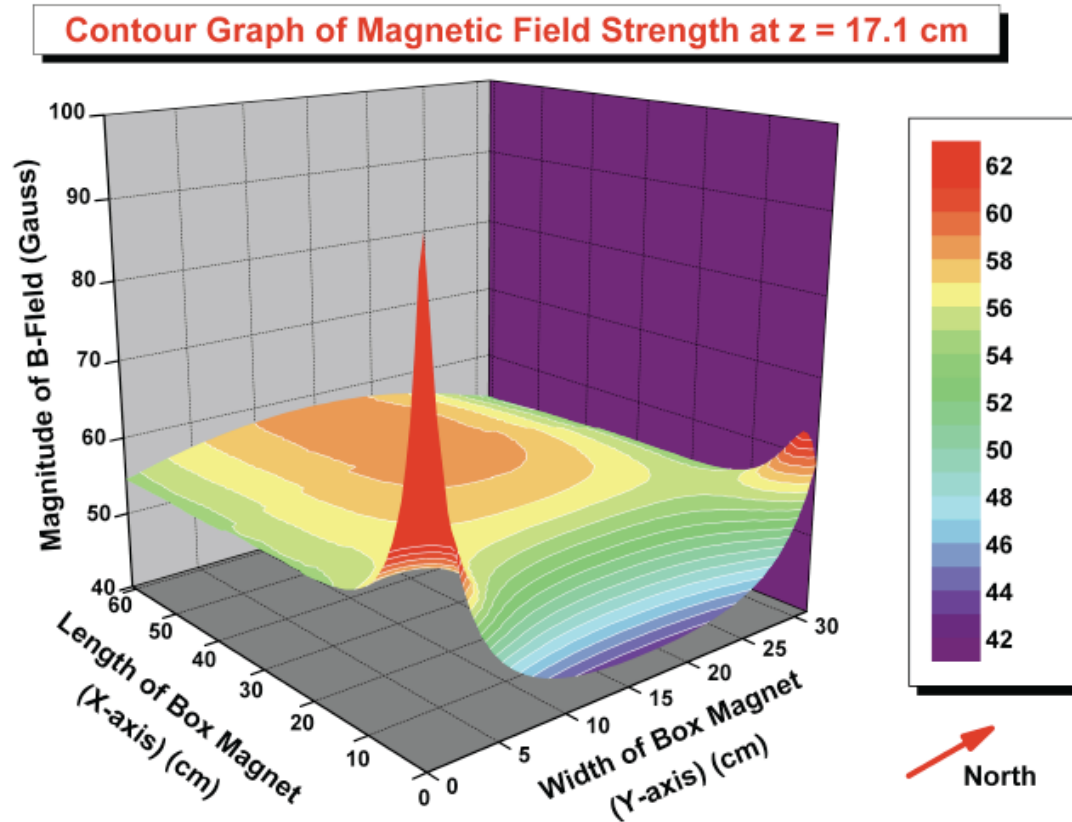

Figure 1.8 Contour graph of magnetic field strength within box magnet. The origin is at the South East corner of the box magnet. Magnitudes above 62 Gauss are colored in red.

## Graphs

# Analysis ...

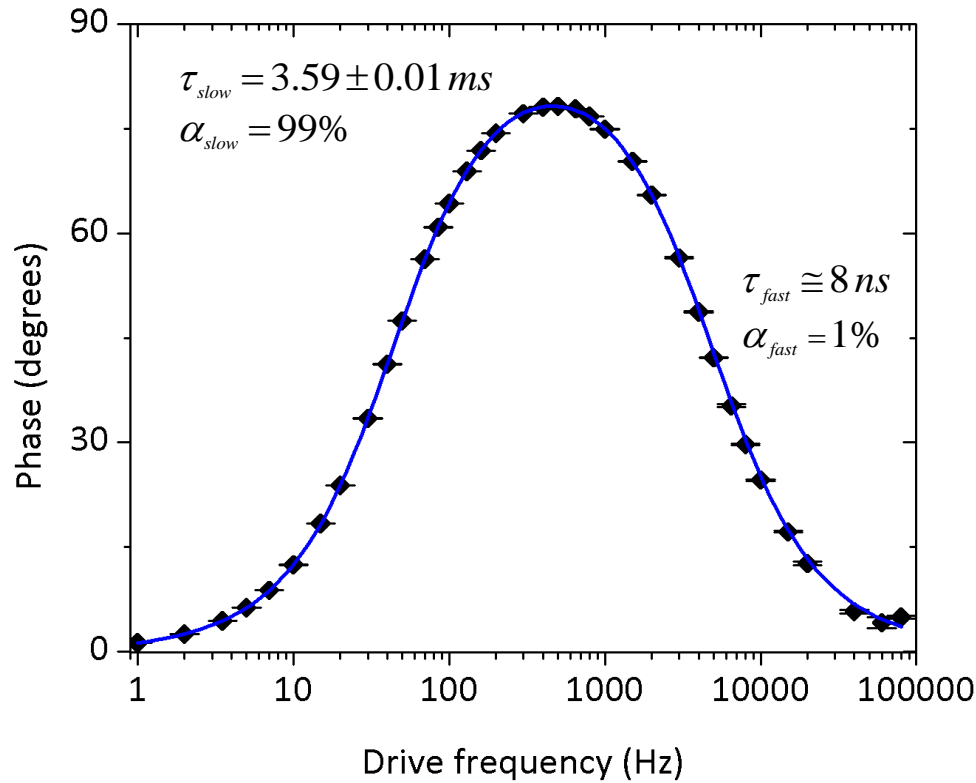

Figure 6. The phase of the ruby fluorescence response to a squarewave excitation is plotted for select driving frequencies from 1 Hz to 80 kHz. A fit to the two-component phase model is plotted in blue.

## Graphs

# Analysis ...

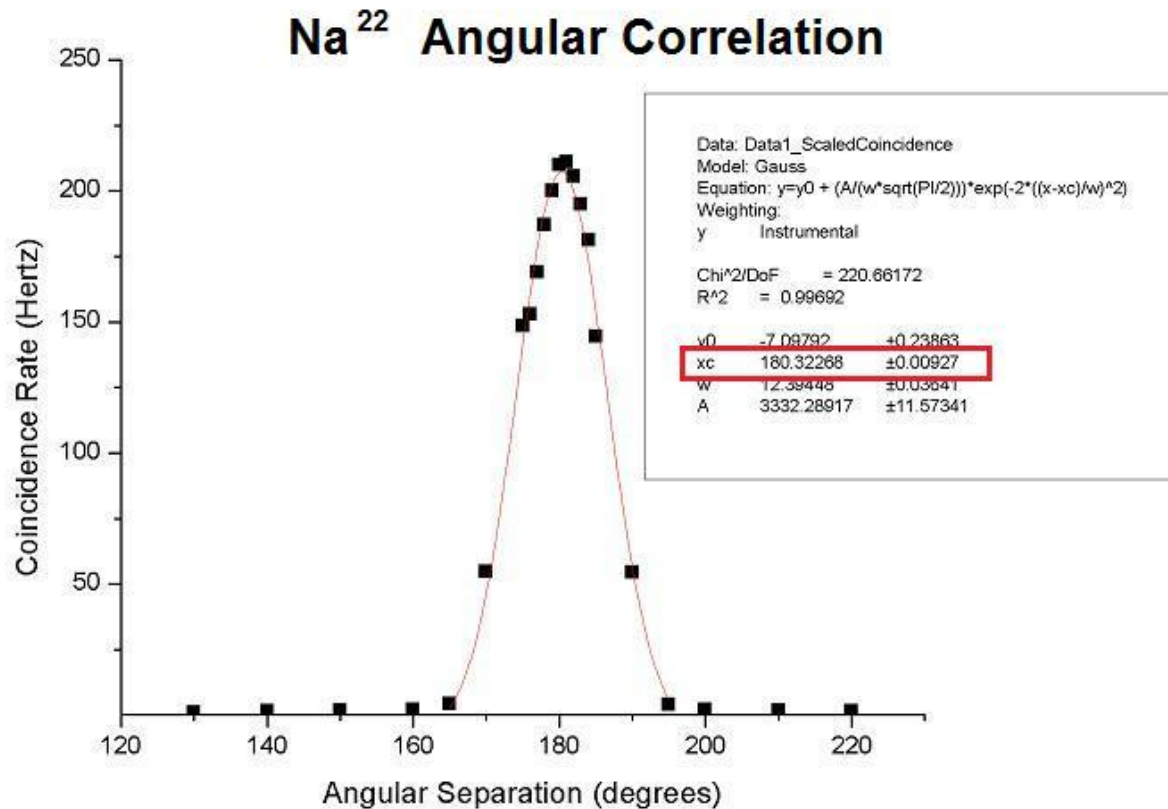

Figure 8: The coincidence rate between Det A and Det B as a function of angular separation between them. Since the positronium that annihilates to emit two 511 KeV gamma rays is in the lab frame, momentum conservation predicts a delta function of coincidences at 180 degree separation.

**Graphs + fitting**

# Analysis ...

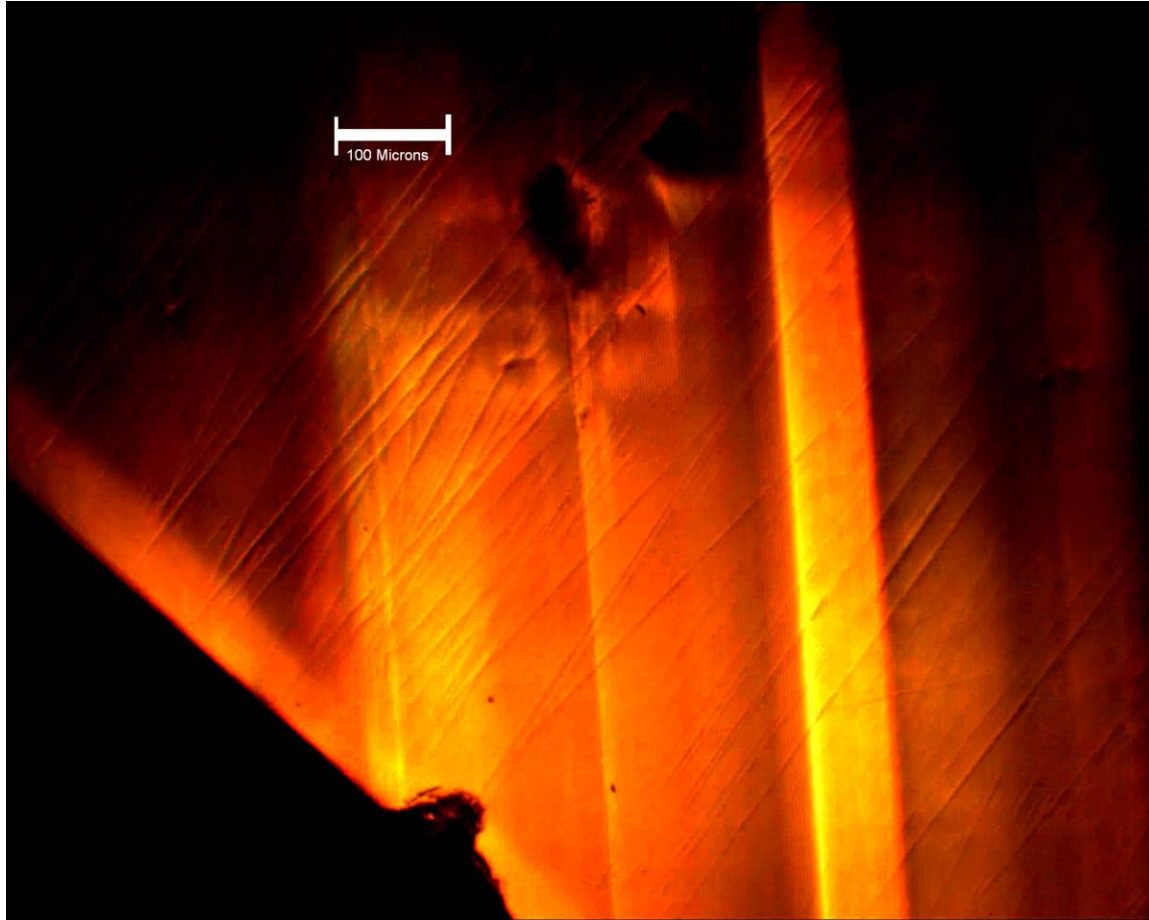

Figure 6: Ferroelectric Domains at 115 K; Edge Picture

**Microscope images**

# Discussion (if needed)

## DISCUSSION

Although both tests presented results that concurred with expectations, it must be noted that the  $T_2$  results, with its more consistent fits and trends, is therefore more reliable than the collected  $T_1$  data. Problems encountered when collecting  $T_1$  data included a significant amount of signal noise, sometimes as high as 0.02V – this is why the  $T_1$  fits were conducted without the data points immediately preceding and following the zero crossing, and also why the zero crossing method cannot be implemented as a secondary method for calculating  $T_1$ .

Secondly, it was observed that an anomalous signal peak appeared to the left of the expected decay peak at Delay Times above 10ms. Although the presence of this peak is unexplained, it would no doubt have had an influence on the weaker decay peaks, likely introducing a gain in the peak height. Additionally, it poses the problem of having the observer judge where signal data should be observed and collected from, since the additional peak initially manifests itself as a seeming shift in the decay peak to the left; at Delay Times of 30ms and higher, however, it becomes progressively clearer that this anomalous peak is not indeed the desired decay signal. Despite this, however, the anomalous peak does display variations with curing time similar to that of the decay peak (although not quite as pronounced); thus, it may be of value to study the source and characteristics of this peak.

# End matter ...

## CONCLUSION

The studied epoxy sample, with its increasing  $T_1$  and decreasing  $T_2$ , presented results that generally concurred with expected trends. With a greater pool of data appropriate cross-referencing, it is conceivable that PNMR could be used as a non-invasive means of determining the extent of curing of an epoxy sample. Using the same principles, PNMR could be used to ascertain the energetics and kinetics of other reactions as well.

## REFERENCES

- [1] P.B. Littlewood, Physics of ferroelectrics (2002)
- [2] R.C. Vernon(1954), Ferroelectricity, American Journal of Physics, 23(4)
- [3] F. Jona, G. Shirane, Ferroelectric crystals, Dover Publications, Inc. New York
- [4] M. Treiner, Ferroelectrics and the Curie-Weiss Law
- [5] Micheal C, Landau Theory of Second Order Phase Transition, Caltech Statistical Mechanics Note
- [6], [7] S. P. DOLIN, T. Yu. MIKHAILOVA, M. V. SOLIN, N. N. BRESLAVSKAYA, A. A. LEVIN *N.S. Kurnakov Institute of General and Inorganic Chemistry, RAS, Leninskii pr. 31, Moscow 119991, Russia*
- [8], [9] C. Kittel, Introduction to Solid State Physics, 7<sup>th</sup> Edition, Chapter 13.
- [10] T. Klaus, K. Nygren, Ferroelectrics laboratory report for Phy403 (2010)
- [11] J.A.Gonzalo, Thermal Hysteresis and Quadrupole Interactions in Ferroelectric Transition
- [12] G.A.Samara, the Effects of Deuteration on the Static Ferroelectric Properties of KDP
- [13] The study of ferroelectric material is rewarding in that ferroelectric material can act as dielectric material between capacitors to make the capacitance tunable. With the small size of ferroelectric material, it is widely applicable in mobile devices nowadays.

# End matter ...

## APPENDIX

### tdcsumfit.cpp

```
doit()
{
MuLife->Draw("TDCSUM/500>>SUM(200,0,8)", "", "");
SUM->SetYTitle("Counts");
SUM->SetXTitle("Time [us]");
SUM==SUM;
user=new TF1("user", "[0]*exp(-(x-0.1)/([1]))+[2]*exp(-(x-
0.1)/([3]))+[4]", .1, 7.5);
user->SetParameters(300, 2.2, 250, 0.85, 10);
user->SetLineColor(4);
user->SetParNames("Ratio:
Plus/Minus", "TauPlus", "AmpMinus", "TauMinus", "Background");
SUM->Fit("user", "R");
}
```

### tdcsumfit2.cpp

```
doit()
{
MuLife->Draw("TDCSUM/500>>SUM(200,0,8)", "", "");
SUM->SetYTitle("Counts");
SUM->SetXTitle("Time [us]");
SUM==SUM;
user=new TF1("user", "[0]*[2]*exp(-(x-0.1)/([1]))+[2]*exp(-(x-
0.1)/([3]))+[4]", .1, 7.5);
user->SetParameters(1.2, 2.2, 250, 0.85, 10);
user->SetLineColor(4);
user->SetParNames("Ratio:
Plus/Minus", "TauPlus", "AmpMinus", "TauMinus", "Backgroud");
SUM->Fit("user", "R");
}
```

# How long?

- ~10 – 15 pages
- If you have lots of plots or photos that serve to complete your work, you can put them in an appendix if you really just want to keep all the stuff together

# In addition, a good report is technically solid

- Spell checked and **proofread**
- Figures should be clear and polished
- **Figures have figure captions** that contain enough information so that the figure and its caption could be clipped out and viewed separately
- Tables also should **have captions**
- You will need to use **references**