

Optical Spectroscopy

Alexey Bezryadin, Virginia Lorenz Kai Wen Teng

PHYS 403

Spring 2023

What is optical spectroscopy

Optical spectroscopy

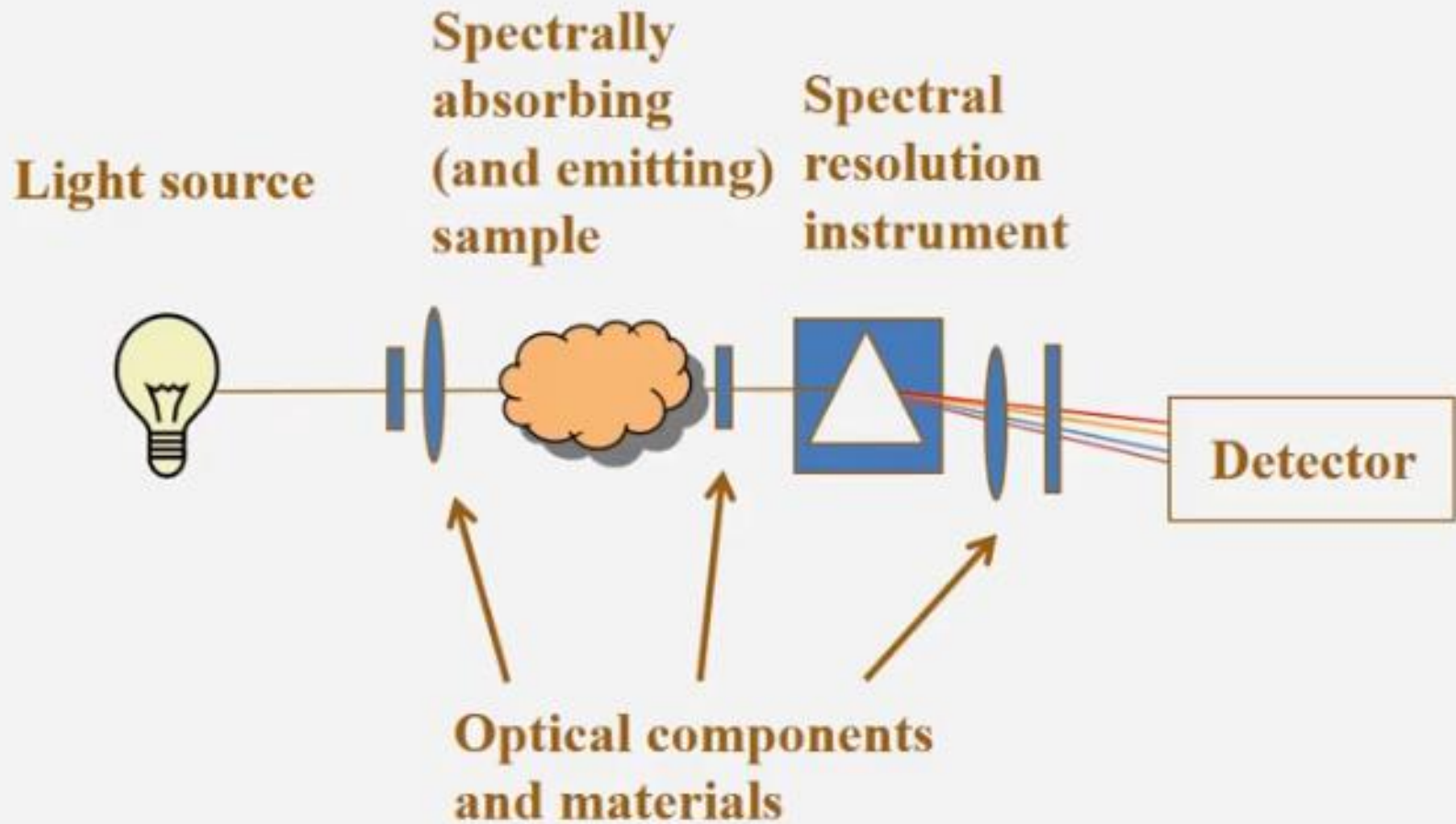

Example

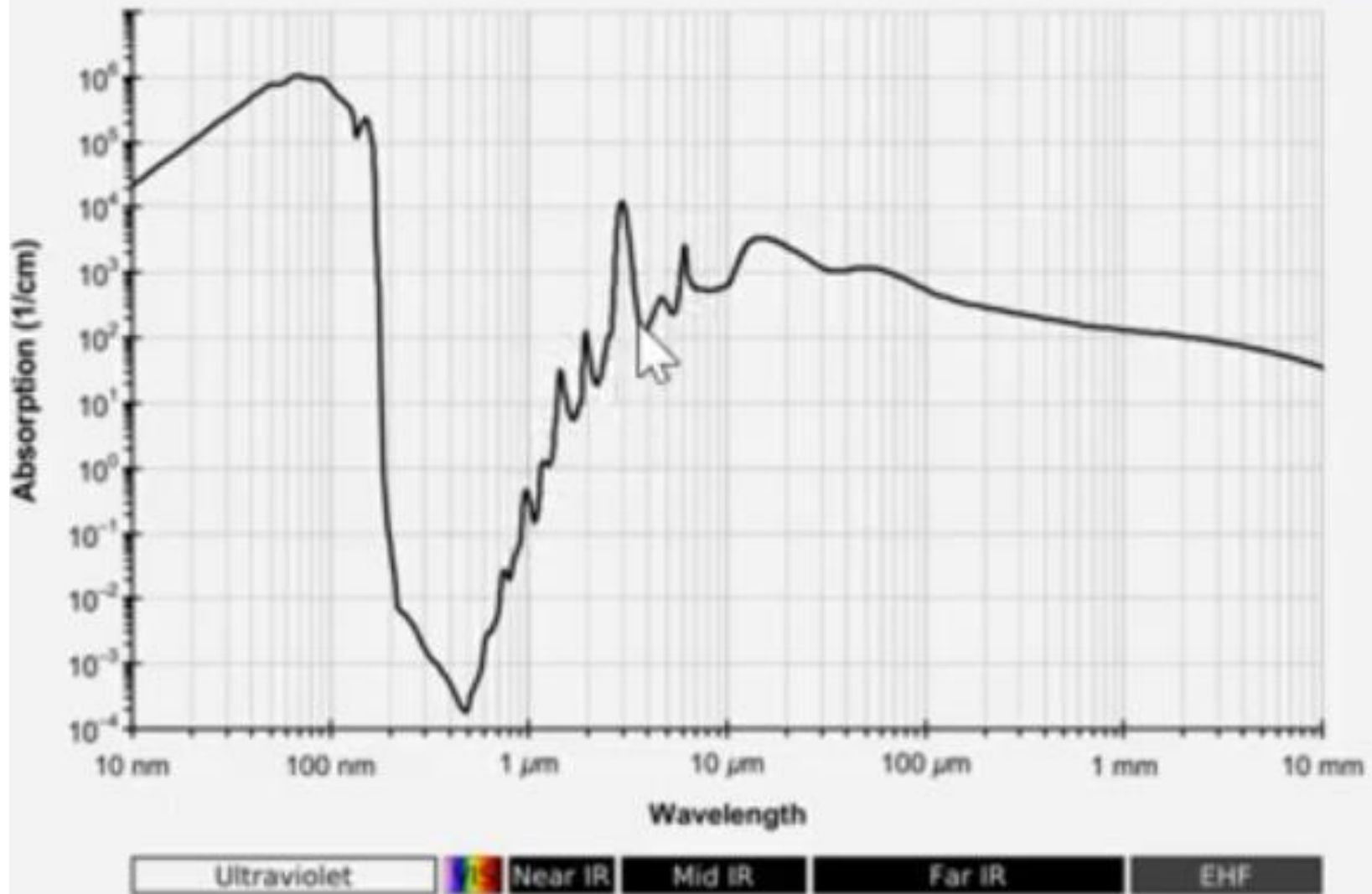

The visible and UV spectra of liquid water

What is light: wave and photon

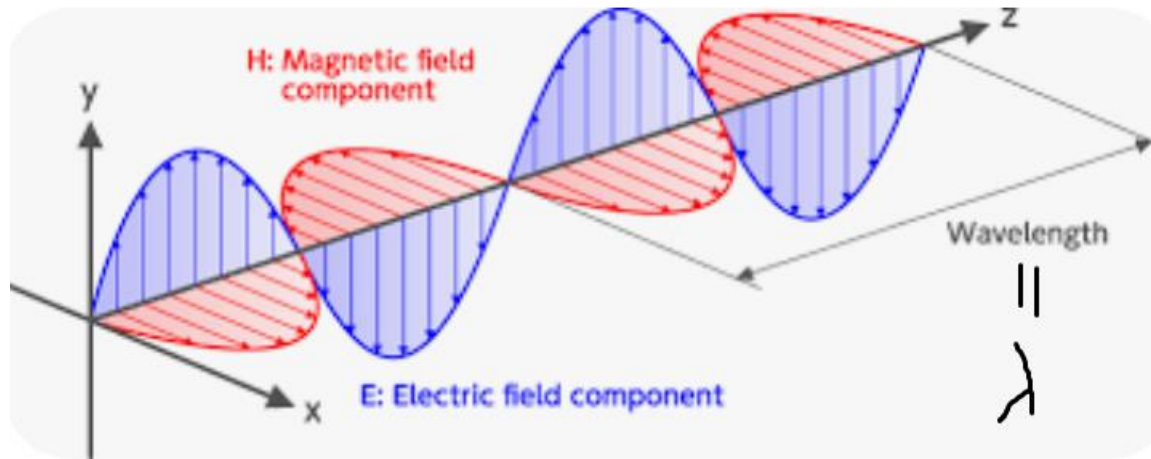

Main formulas:

1. Wave formula: frequency*wavelength=speed of light; $c = f \lambda$
2. Planck's formula: energy of one quantum (photon) $E = h f$

Here h is Planck's constant

3. Light is a transverse wave.
4. The direction of the electric field is called "polarization direction"
5. Photons carry spin (angular momentum), which equals \hbar , which is the "reduced Planck's constant".

De Broglie standing wave - electronic orbitals

Each stable closed orbit must have a length equal to the wavelength multiplied by an integer.

The Stationary States of the Hydrogen Atom

- The de Broglie wavelength for a particle *has* to be $\lambda = h/p = h/mv$. Thus the standing-wave condition for a de Broglie wave is $2\pi r = n \frac{h}{mv}$

- This condition $v = \frac{nh}{2\pi mr}$ $n = 1, 2, 3, \dots$ is true only if the electron's speed is

- The electron cannot have just any speed, only the discrete values given by this equation.

$$L = r p = m v r = n \frac{h}{2\pi} = n \hbar$$

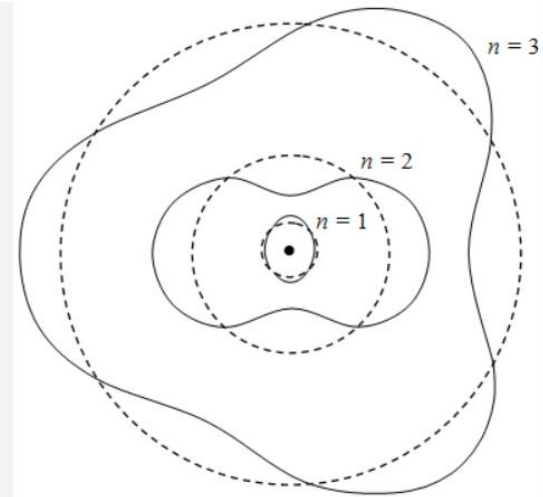

The calculation shows
How the angular momentum
is quantized.

Key idea: a photon can be absorbed by the atom, in which case the electron transitions to a higher orbit.

De Broglie standing wave - electronic orbitals

Each stable closed orbit must have a length equal to the wavelength multiplied by an integer.

The Stationary States of the Hydrogen Atom

- The de Broglie wavelength for a particle *has* to be $\lambda = h/p = h/mv$. Thus the standing-wave condition for a de Broglie wave is $2\pi r = n \frac{h}{mv}$

- This condition $v = \frac{nh}{2\pi mr}$ $n = 1, 2, 3, \dots$ is true only if the electron's speed is

- The electron cannot have just any speed, only the discrete values given by this equation.

$$L = r p = m v r = n \frac{h}{2\pi} = n \hbar$$

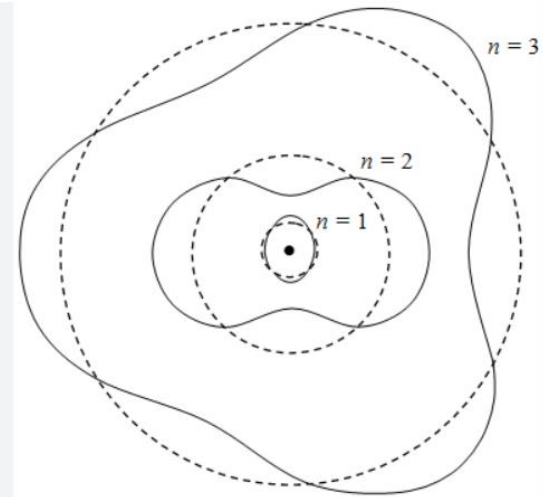

The calculation shows
How the angular momentum
is quantized.

Key idea: a photon can be absorbed by the atom, in which case the electron transitions to a higher orbit.

How to calculate De Broglie standing wave - solve the Schrodinger equation

Application of the Schrödinger Equation to the Hydrogen Atom

- Potential energy of the electron-proton system is electrostatic (no magnetic effects in the beginning):

$$V(r) = -\frac{e^2}{4\pi\epsilon_0 r}$$

- Rewrite the three-dimensional time-independent Schrödinger Equation.

$$-\frac{\hbar^2}{2m} \frac{1}{\psi(x, y, z)} \left[\frac{\partial^2 \psi(x, y, z)}{\partial x^2} + \frac{\partial^2 \psi(x, y, z)}{\partial y^2} + \frac{\partial^2 \psi(x, y, z)}{\partial z^2} \right] = E - V(r)$$

Energy bands in molecules and solids



Band structure of Solids

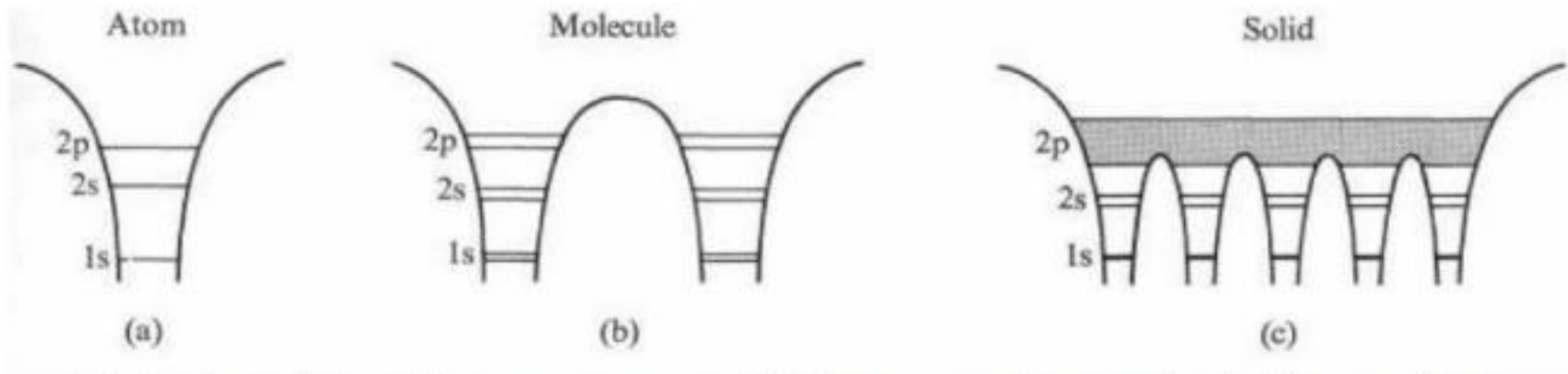

Fig.1 The evolution of the energy spectrum of Li from an atom (a), to a molecule (b), to a solid (c).

**The energy spectrum gradually changes
as atoms are assembled to form the solid**

Dr. Md. Snerjul Islam
Associate Professor

Energy bands in molecules and solids

Significant leap required for an electron to move to the next higher level



Single atom

Shorter leap required

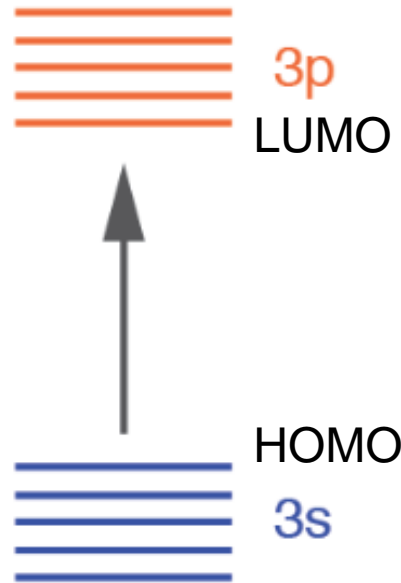

Five atoms in close proximity

Overlap permits electrons to freely drift between bands

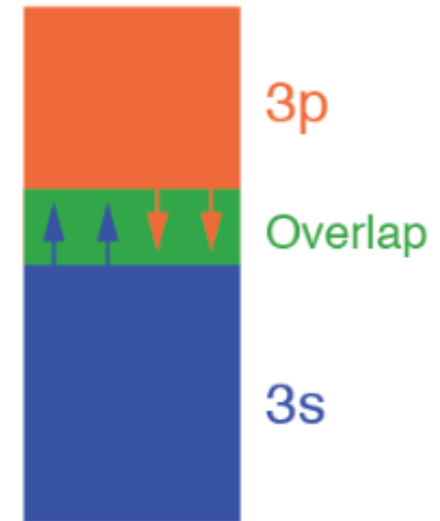

Multitudes of atoms in close proximity

Energy bands in molecules and solids

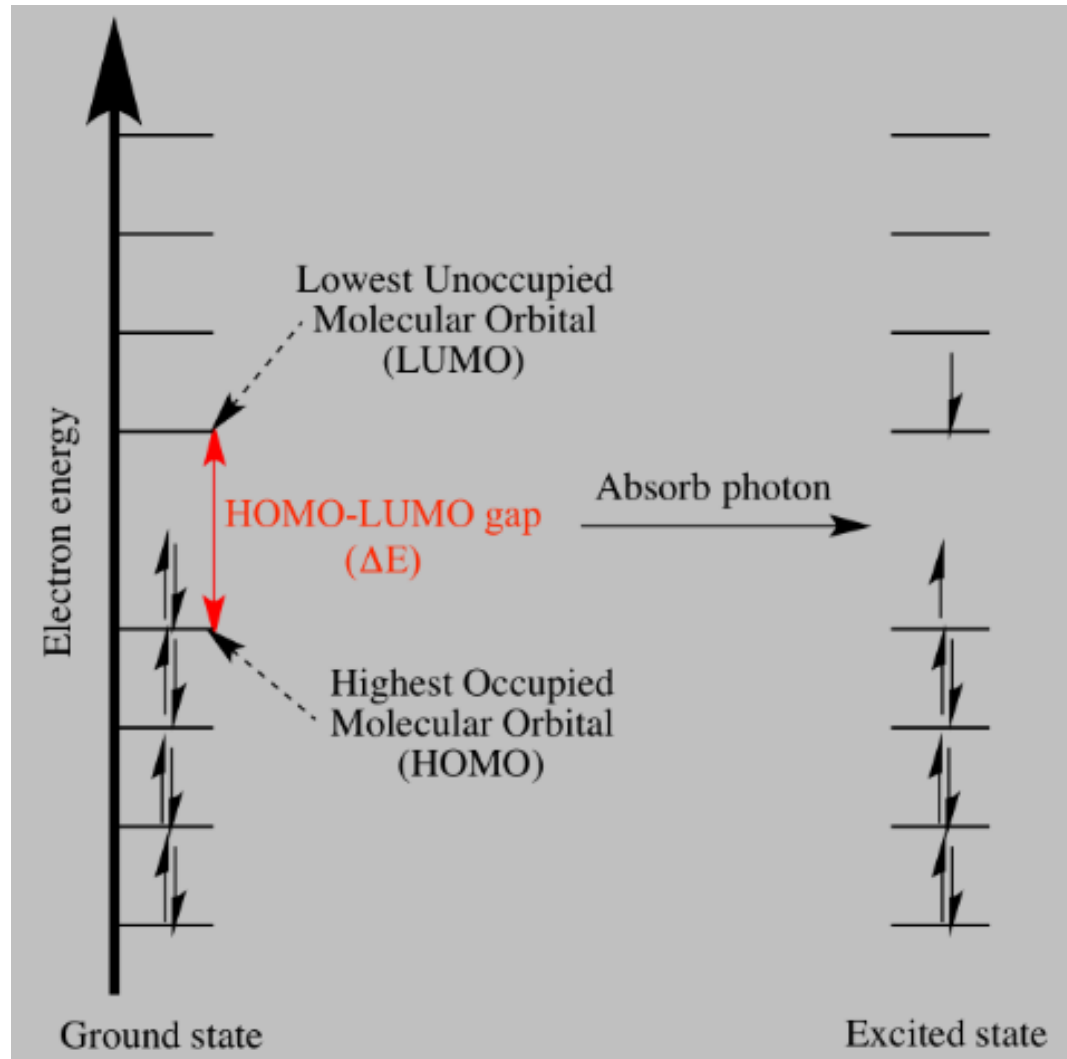

Each arrow represents an electron. Each electron has internal angular momentum, called "spin" which can be either $+1/2$ (up) or $-1/2$ (down).

Electromagnetic Spectrum of atoms and molecules

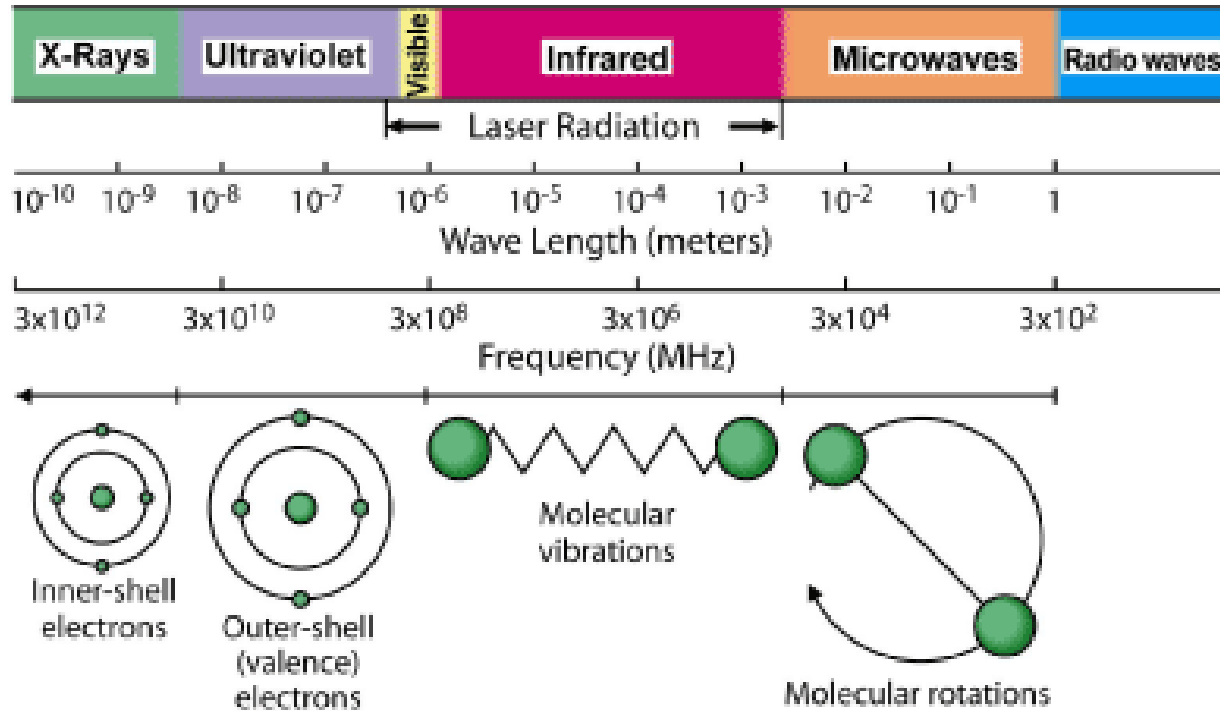

From <http://de.cem.com>

<https://www.olympus-lifescience.com/en/microscope-resource/primer/techniques/fluorescence/fluorescenceintro/>

Luminescence and Photoluminescence

Luminescence is the emission of light produced by methods other than heat. Luminescence is caused by the movement of electrons from higher energy states to lower energy states. There are many different types of luminescence including bioluminescence, chemiluminescence, phosphorescence, and fluorescence.

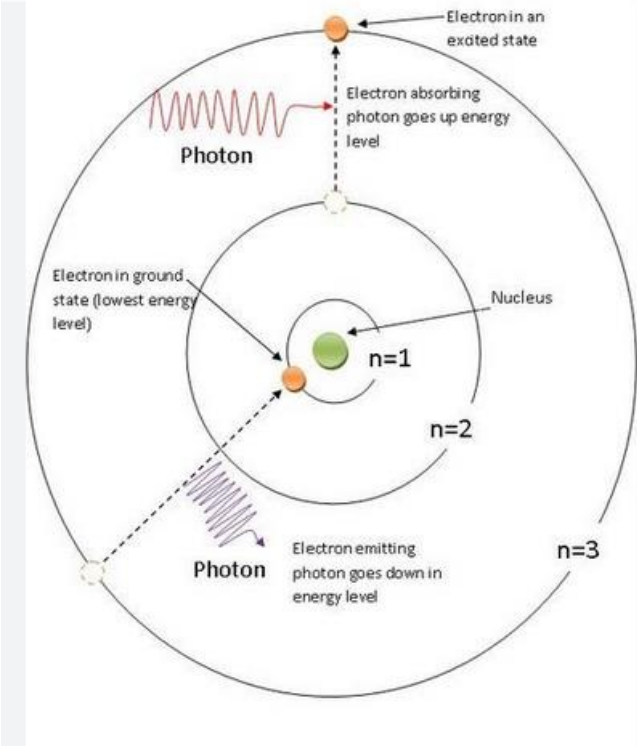

Fluorescent solutions under UV light. Absorbed photons are rapidly re-emitted under longer electromagnetic wavelengths.

Photoluminescence (abbreviated as **PL**) is light emission from any form of matter after the absorption of photons (electromagnetic radiation).

Fluorescence vs Phosphorescence

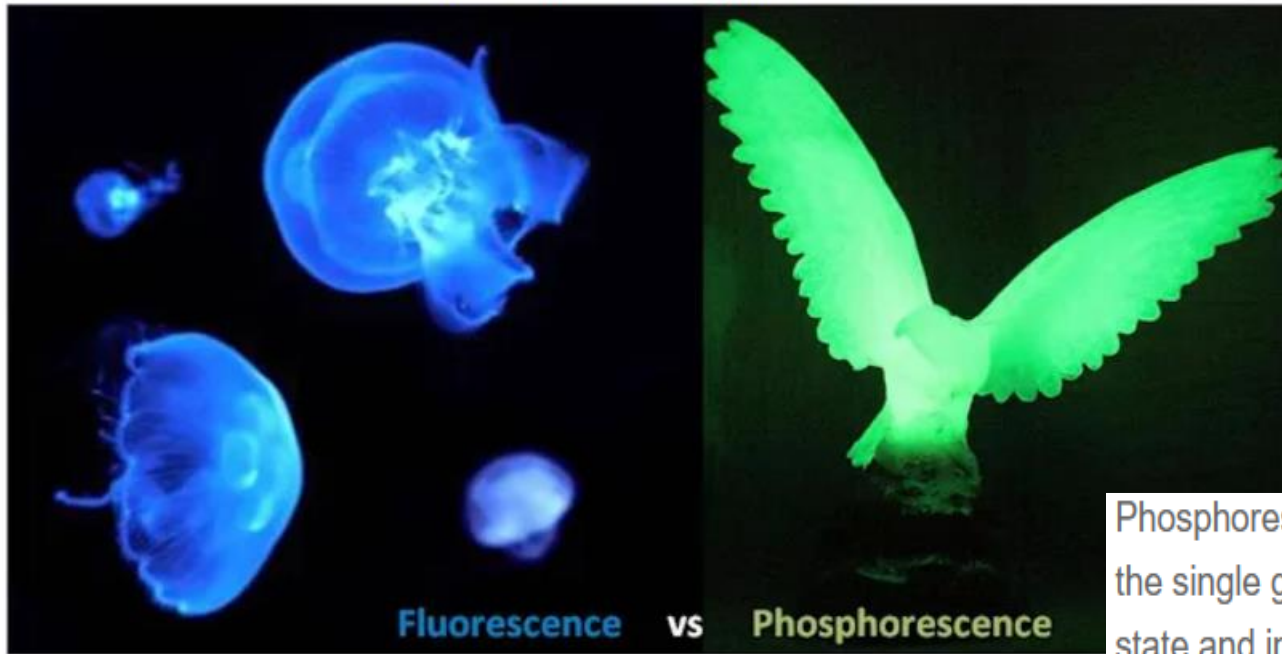

Phosphorescence involves the transition from the single ground energy state to excited triplet state and involving a change of spin state

Fluorescence is a two-stage chemical process involving absorption of shorter-wavelength light by a chemical fluorophore such as a protein or carotenoid (excitation), followed by the release of some of the absorbed energy as longer-wavelength light (emission).

Fluorescence and Phosphorescence

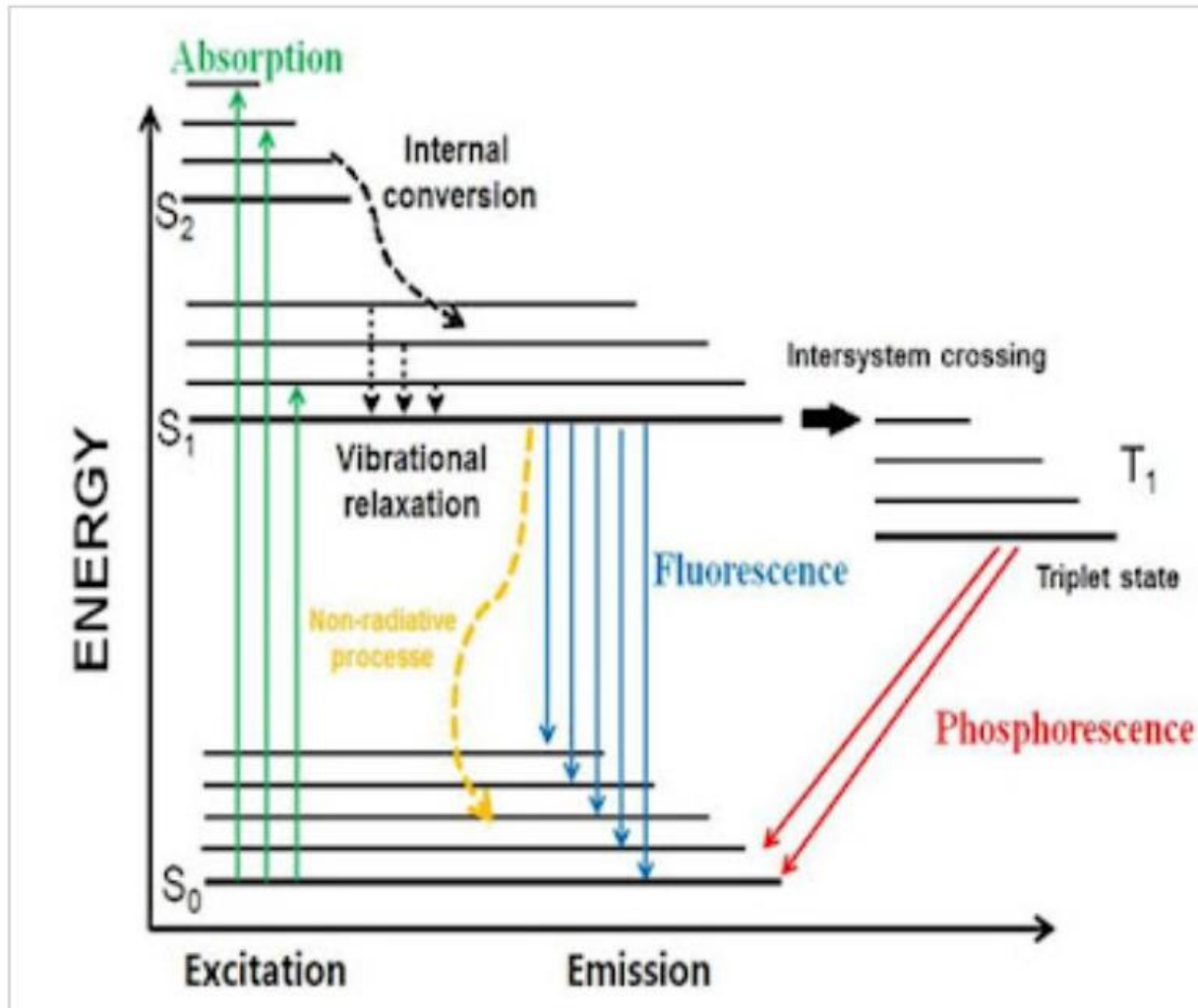

Mechanism of fluorescence and phosphorescence emission.

Singlet states and triplet states

In spectroscopy and quantum chemistry, the **multiplicity** of an energy level is defined as $2S+1$, where S is the total spin angular momentum.^{[1][2][3]} States with multiplicity 1, 2, 3, 4, 5 are respectively called **singlets**, **doublets**, **triplets**, **quartets** and **quintets**.^[2]

In the **ground state** of an atom or molecule, the unpaired electrons usually all have parallel spin. In this case the multiplicity is also equal to the number of unpaired electrons plus one.^[4]

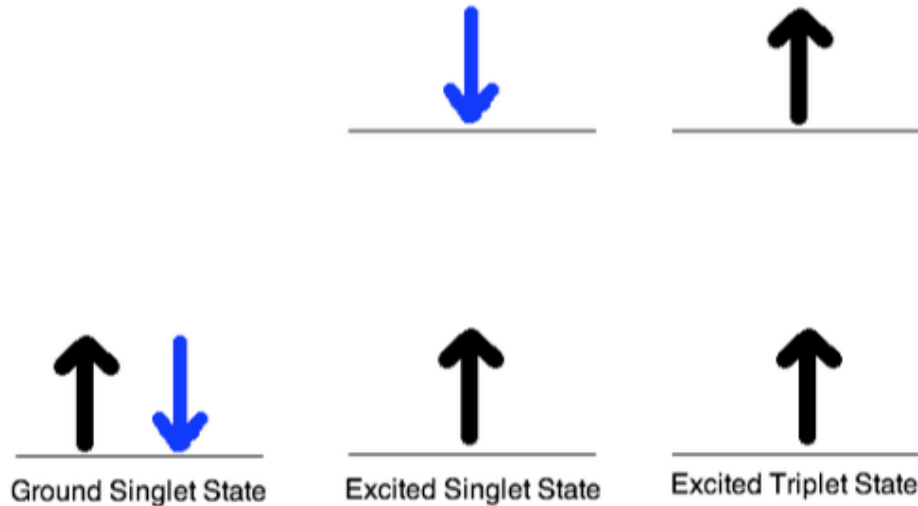

Singlet states and triplet states

In spectroscopy and quantum chemistry, the **multiplicity** of an energy level is defined as $2S+1$, where S is the total spin angular momentum.^{[1][2][3]} States with multiplicity 1, 2, 3, 4, 5 are respectively called **singlets**, **doublets**, **triplets**, **quartets** and **quintets**.^[2]

In the **ground state** of an atom or molecule, the unpaired electrons usually all have parallel spin. In this case the multiplicity is also equal to the number of unpaired electrons plus one.^[4]

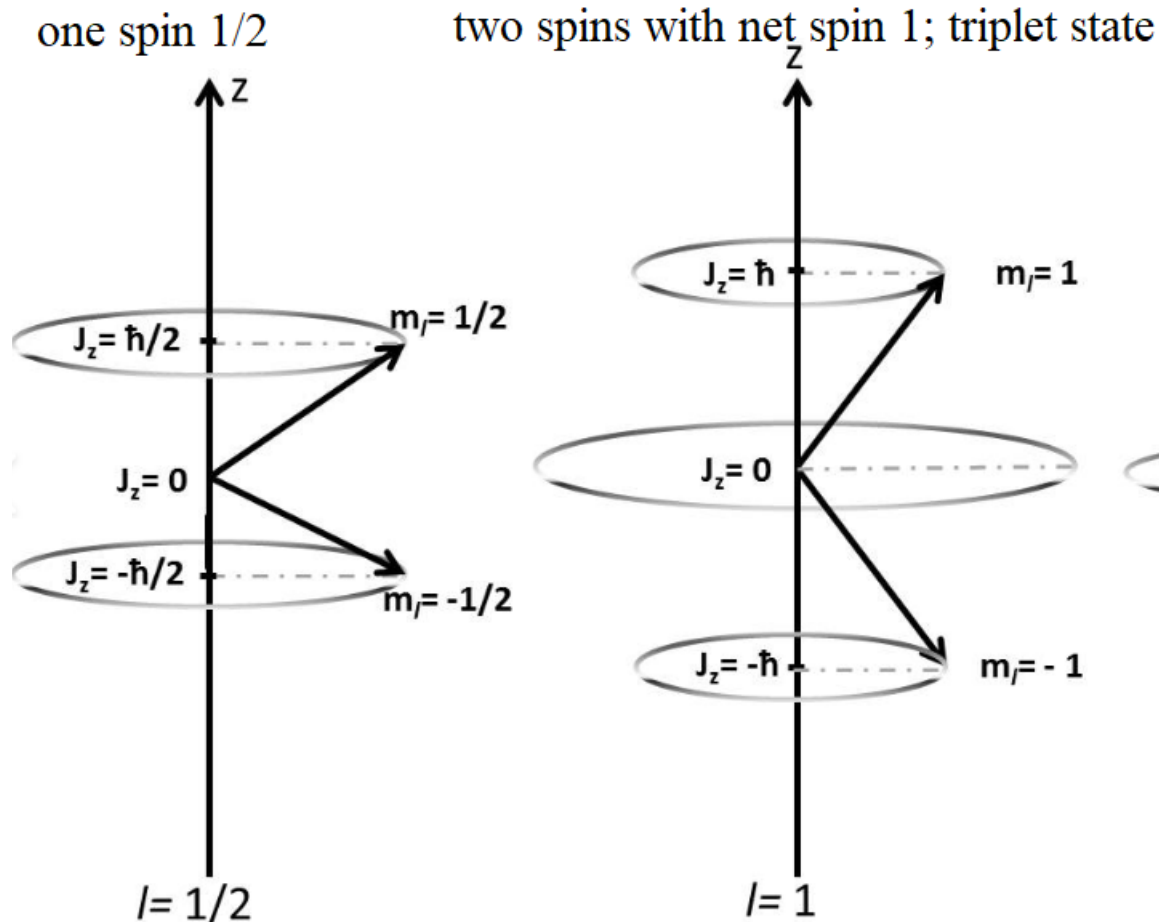

Singlet state has a total zero angular momentum, so it is not shown on the picture. Such state can only have value of its projection: zero. Therefore it is called "singlet".

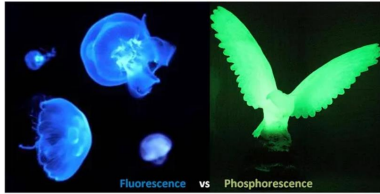

<p>The emitted photon (light) has lower energy than the absorbed photon and emission occurs at a longer wavelength than the incident light</p>	<p>The emitted photon (light) has lower energy than the absorbed photon and emission occurs at a longer wavelength than fluorescence</p>
<p>In fluorescent materials, gives an 'an immediate flash or afterglow' on excitation</p>	<p>Phosphorescent materials appears to 'glow in the dark', because of slow emission of light over time.</p>
<p>Examples of Fluorescence: Gemstones fluoresce, including gypsum, talc. Jelly fish, chlorophyll extract, vitamins etc</p>	<p>Examples of Phosphorescence: Glow of clock dial or toys or in bulbs after switching off the light in the room. The glow remains for some minutes or even hours in a dark room Phosphorescent materials in sign board illuminate during night.</p>

Types of Fluorescent Molecules

Synthetic Organic:
Fluorescein

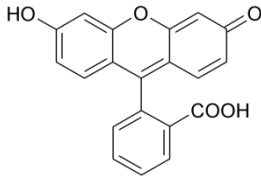

Naturally Occuring:

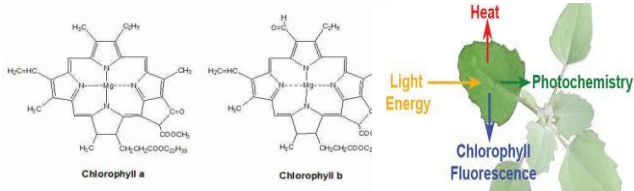

Fluorescent Proteins:

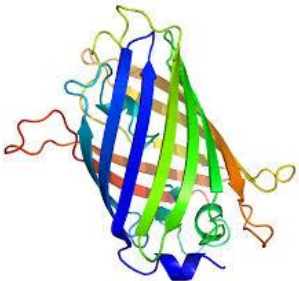

Green Fluorescent Protein

Semiconductor Nanocrystal:

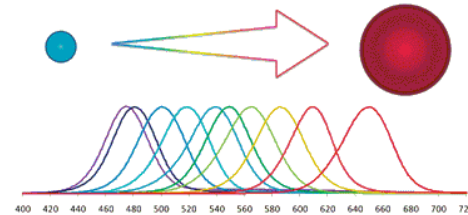
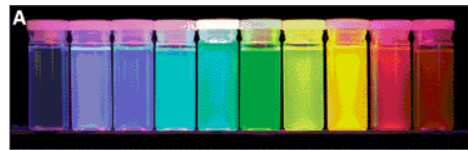
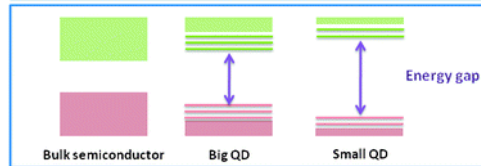
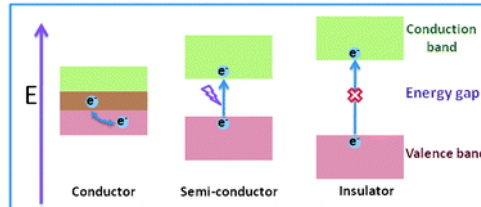
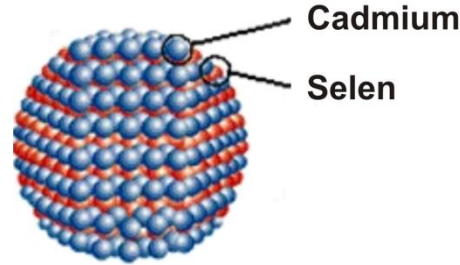
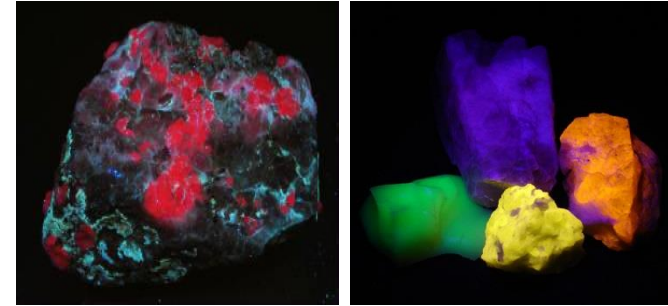

Image from Zrazhevskiy et al. 2010

Crystals:



Ruby and assorted minerals

From mineralman.net

Fluorescent Nanodiamonds

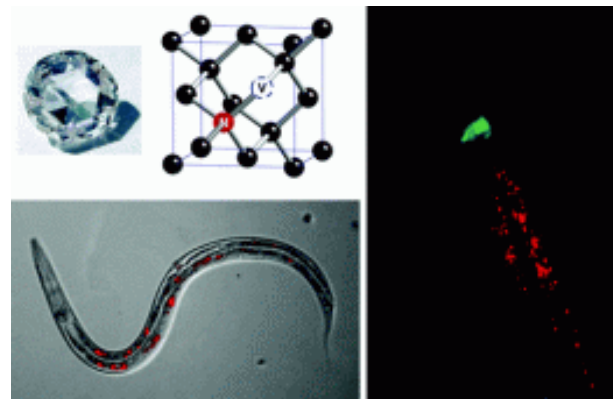

Nano Lett., 2010, 10 (9), pp 3692-3699. DOI: 10.1021/nl1021909

Perrin-Jablonski energy diagram

illustrates the electronic states of a molecule and the transitions between them



Alexander Jabłoński

1898-1980

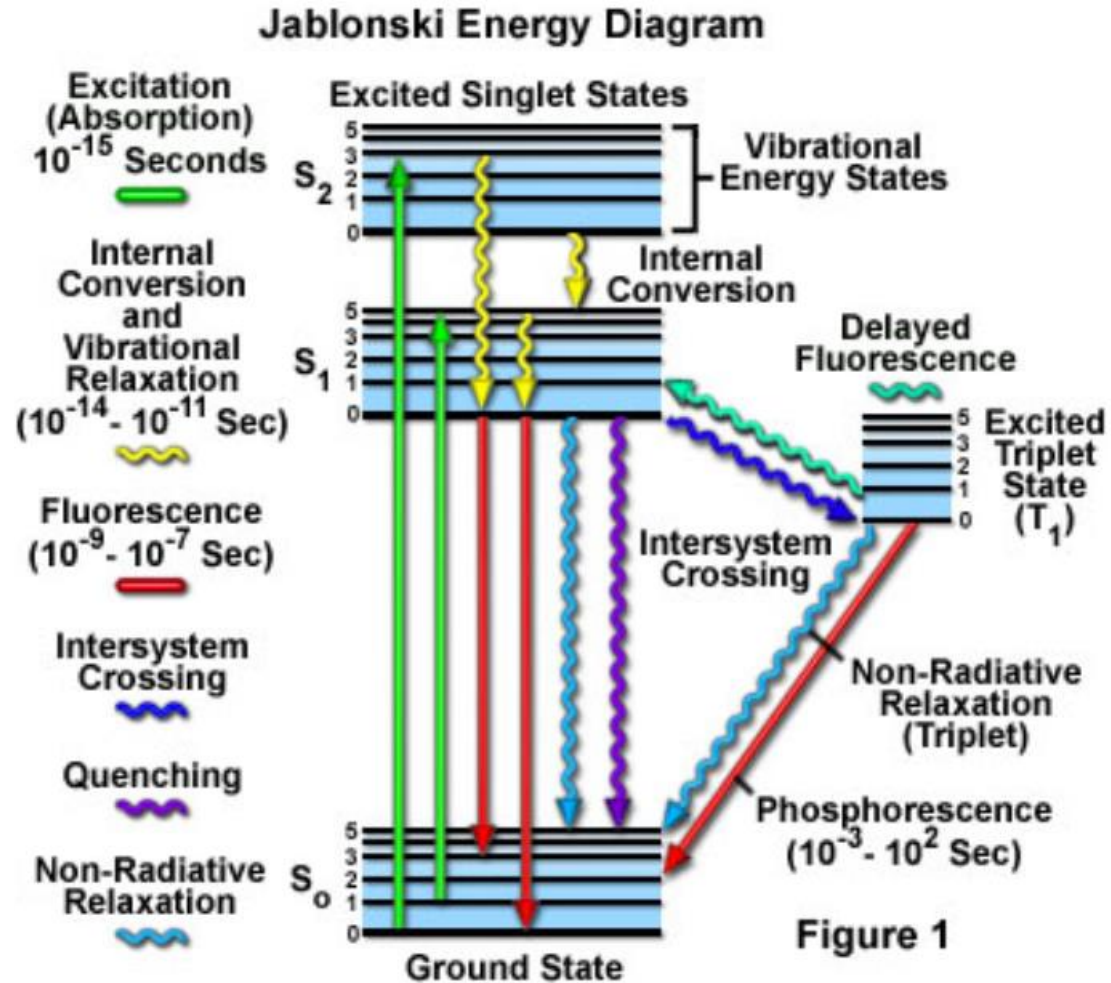

ground electronic singlet state

Perrin-Jablonski energy diagram

illustrates the electronic states of a molecule and the transitions between them

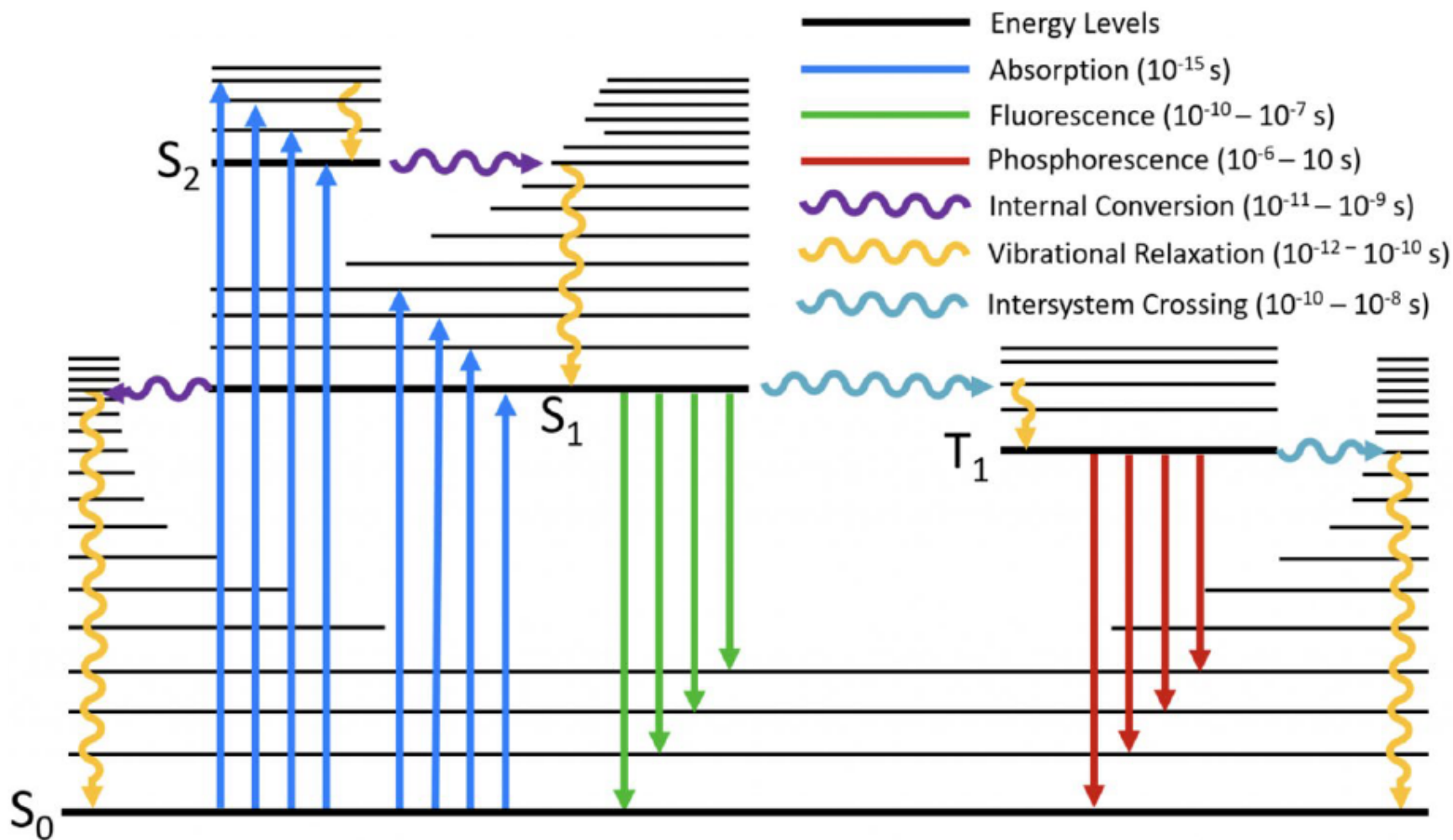

Perrin-Jablonski Diagram *Courtesy Edinburgh Instruments*

Time scales

The fluorescence process is governed by three important events, all of which occur on timescales that are separated by several orders of magnitude.

Excitation of a susceptible molecule by an incoming photon happens in femtoseconds ($10E-15$ seconds), while vibrational relaxation of excited state electrons to the lowest energy level is much slower and can be measured in picoseconds ($10E-12$ seconds). The final process, emission of a longer wavelength photon and return of the molecule to the ground state, occurs in the relatively long time period of nanoseconds ($10E-9$ seconds). Although the entire molecular fluorescence lifetime, from excitation to emission, is measured in only billionths of a second, the phenomenon is a stunning manifestation of the interaction between light and matter that forms the basis for the expansive fields of steady state and time-resolved fluorescence spectroscopy and microscopy.

ground electronic singlet state

Steady State Measurements: Absorbance

One of the very first commercially available instruments that measures absorbance was the Beckman DU spectrophotometer

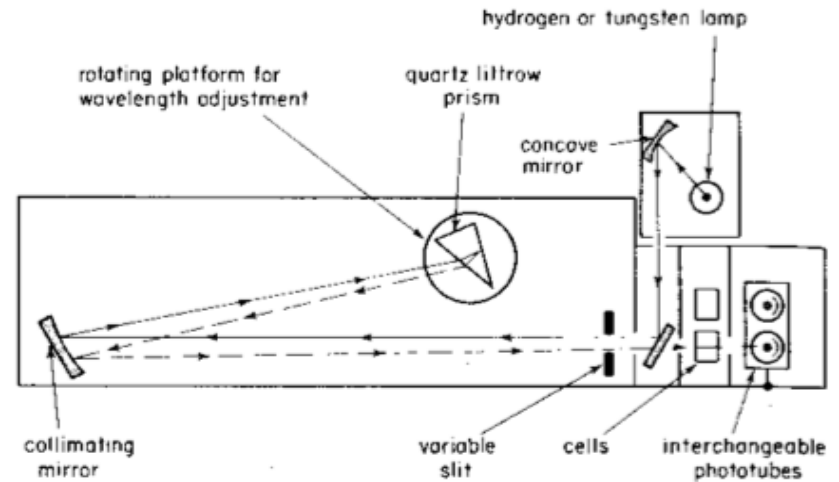

Machines nowadays that utilize diffraction grating and diode array detector can acquire an absorbance spectra in less than 10 seconds.

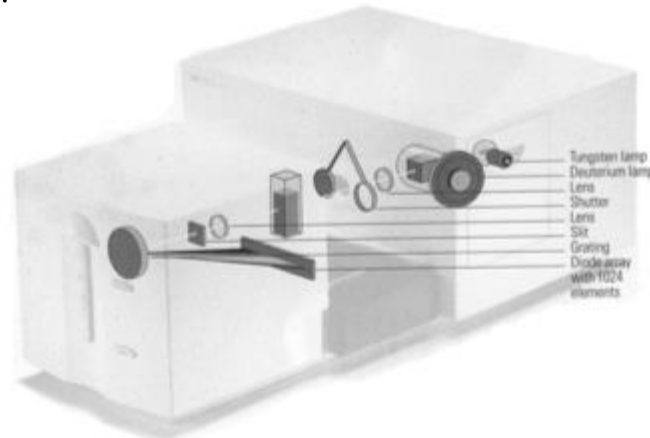

Fluorescence spectroscopy

Schematic view of instrument

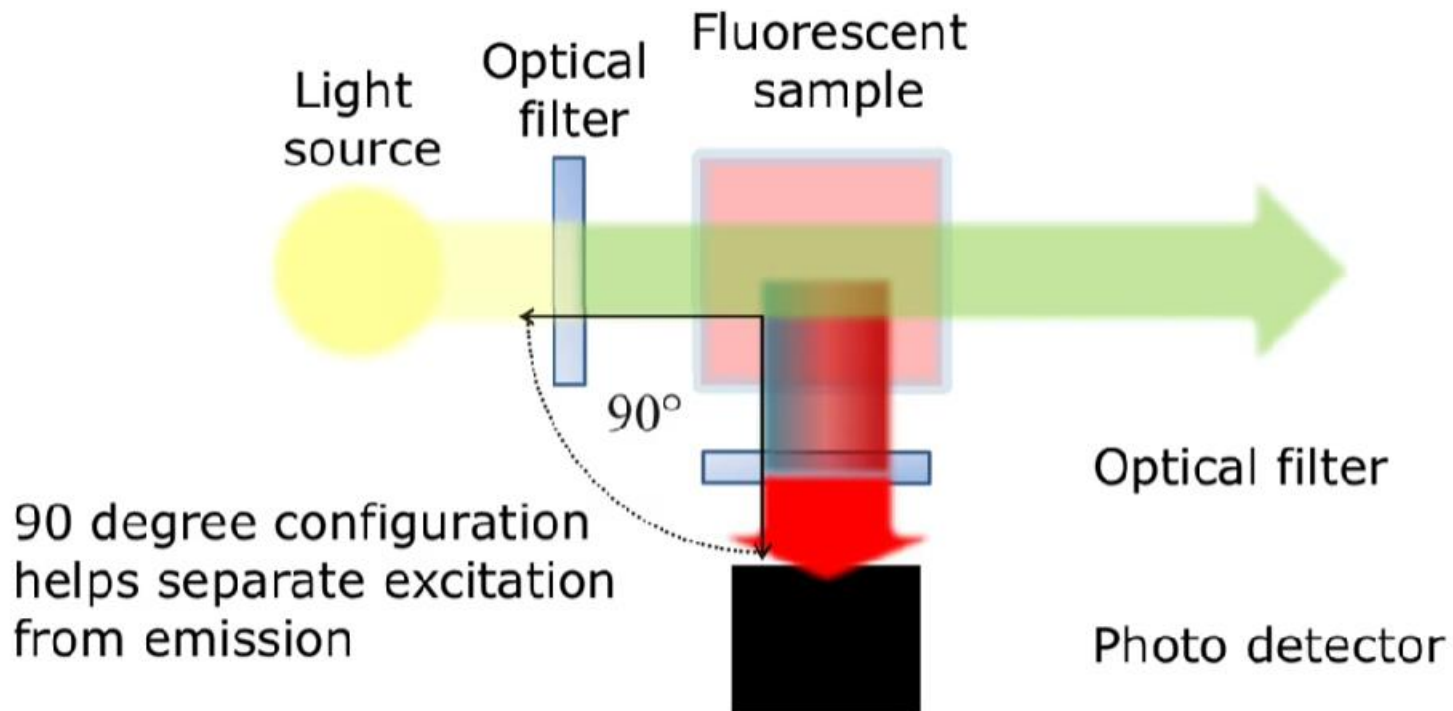

Fluorescence spectroscopy

Optical emission-side

▣ Scanning grating mono-chromator

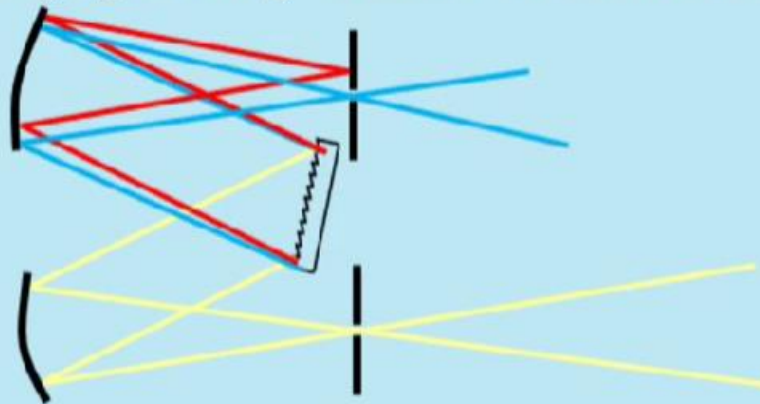

▣ Fixed optical bandpass filter

▣ Scanning linear variable bandpass filter

▣ Diode array spectrometer

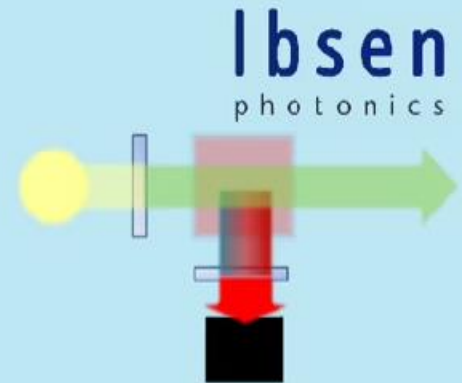

Diffraction grating

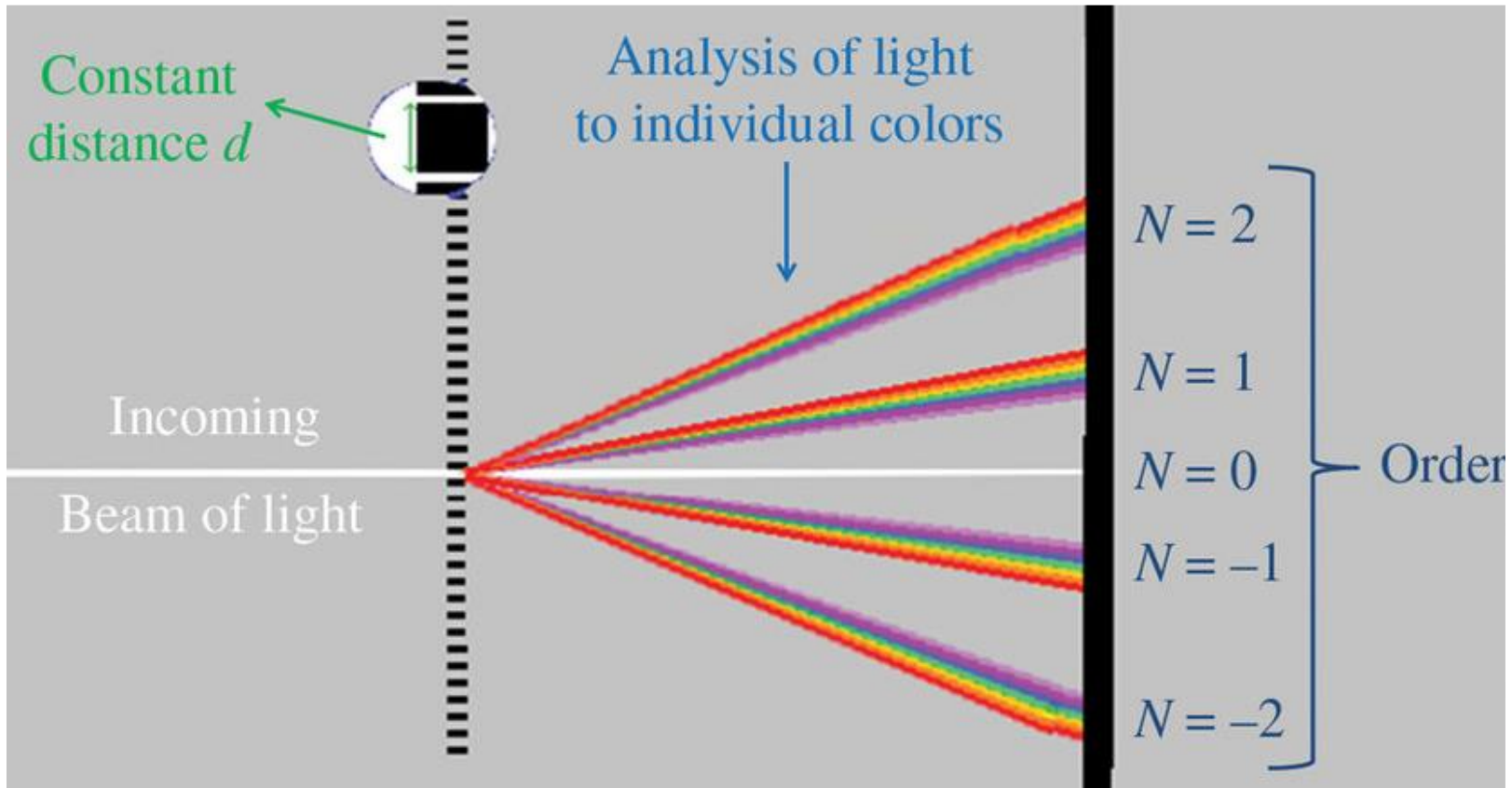

Diffraction grating principle: all waves must be "in phase", in order to get the maximum intensity

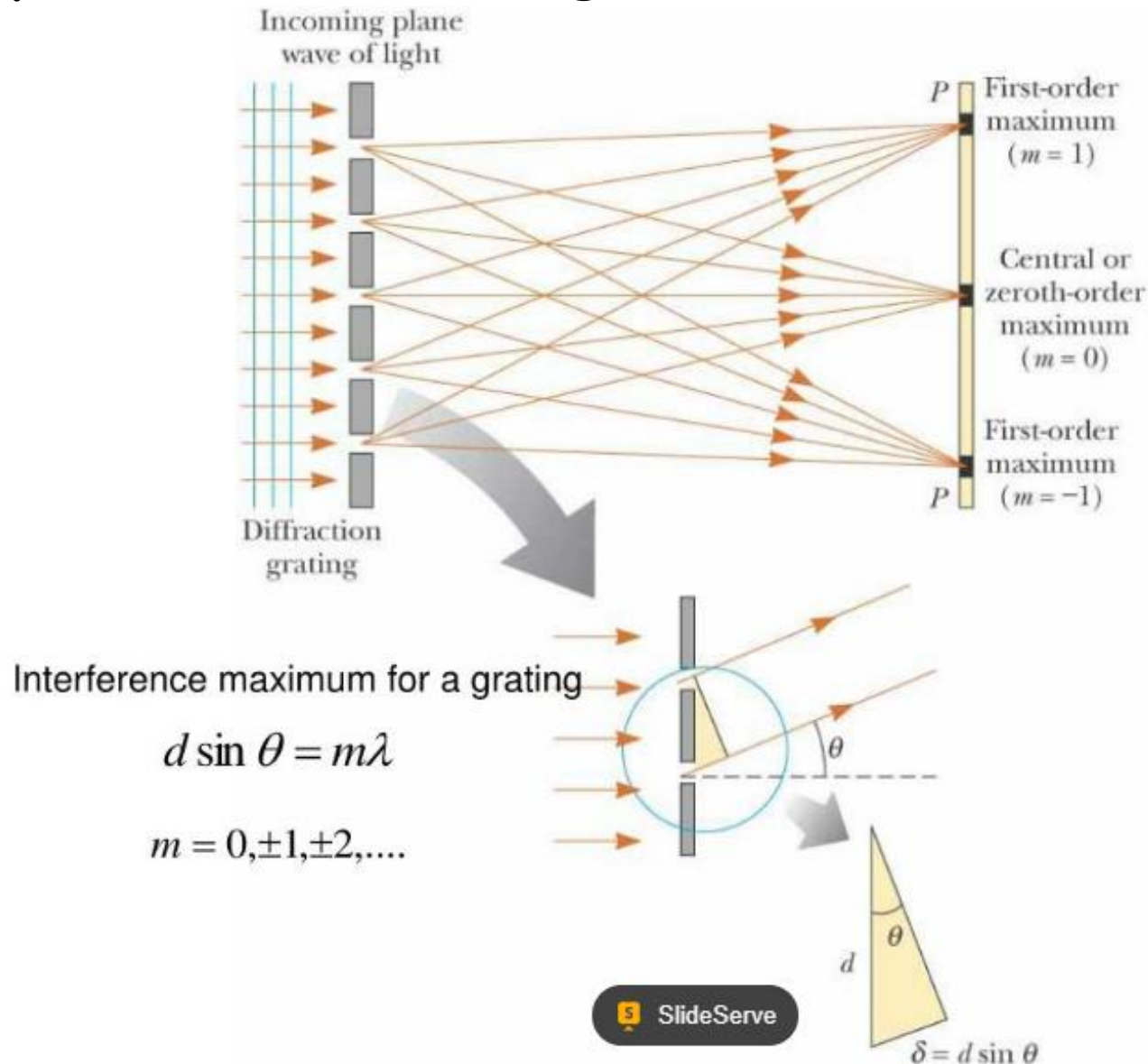

Fluorescence spectroscopy

Natural fluorophores

- Chlorophyll (a and b)
 - Absorbs red and blue wavelengths
 - Reflects green
 - Fluoresces in the red wavelengths

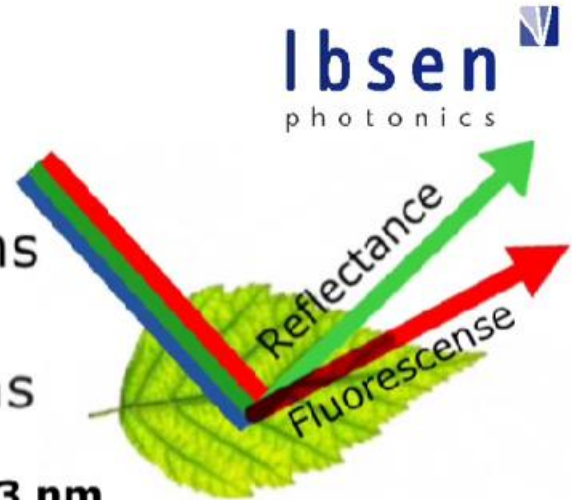

Ibsen
photonics

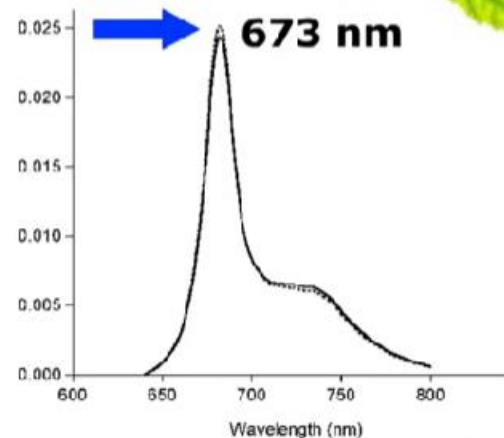
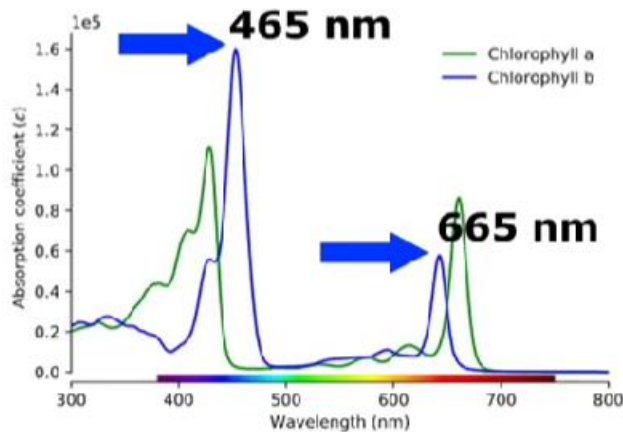

Single Molecule Fluorescence Imaging

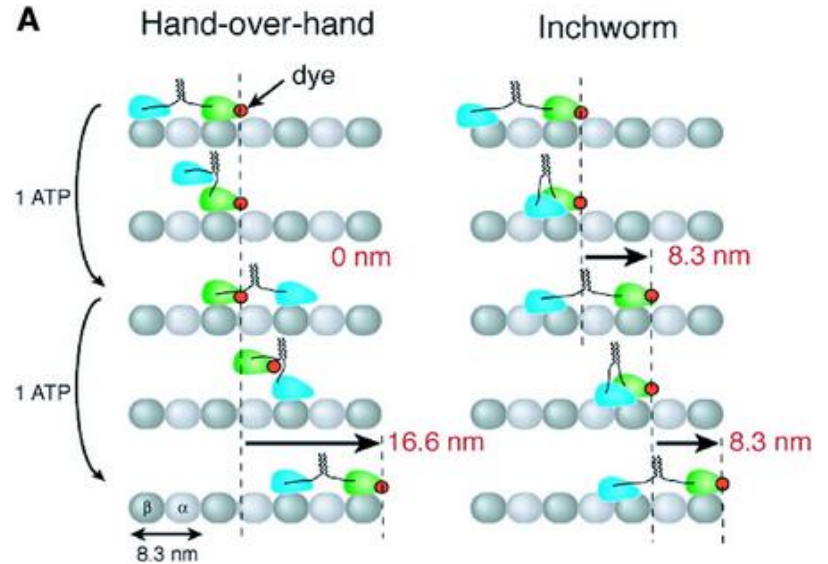
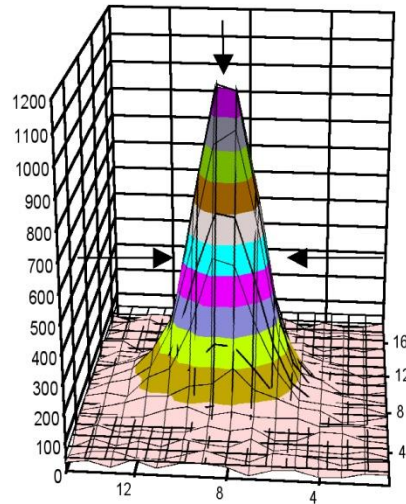
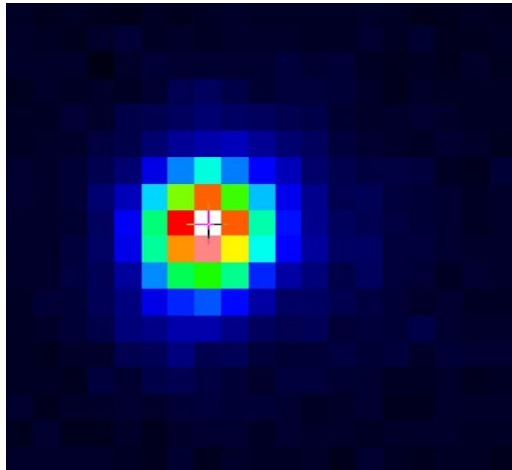

$$\sigma_{\mu_i} = \sqrt{\left(\frac{s_i^2}{N} + \frac{a^2/12}{N} + \frac{8\pi s_i^4 b^2}{a^2 N^2}\right)}$$

Center of the distribution can be determined in ~1.5 nm accuracy if #N is more than 10⁴

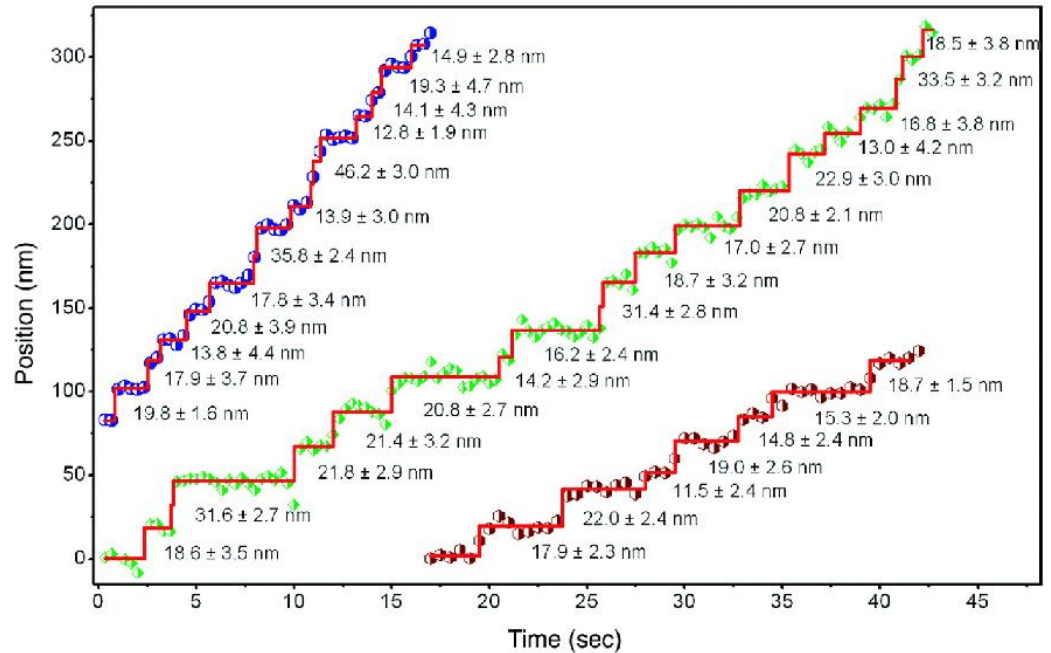

Super Resolution Fluorescence Imaging

Basic Principle of STORM Superresolution Imaging

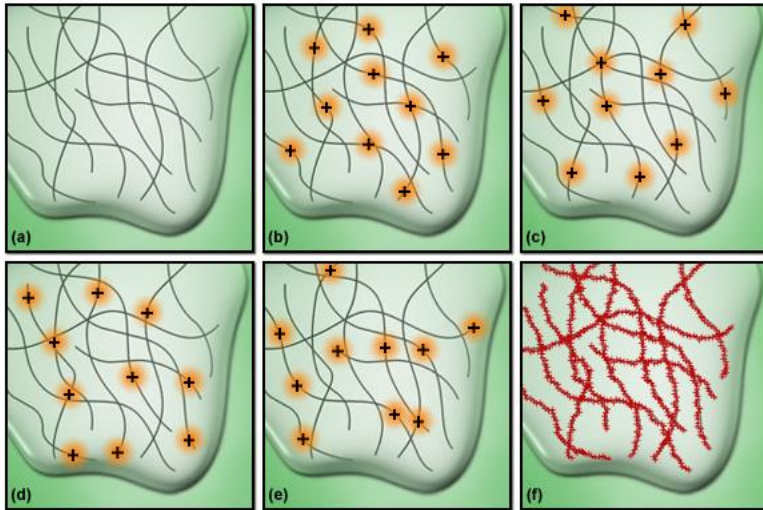

Three-Dimensional Superresolution Imaging with STORM

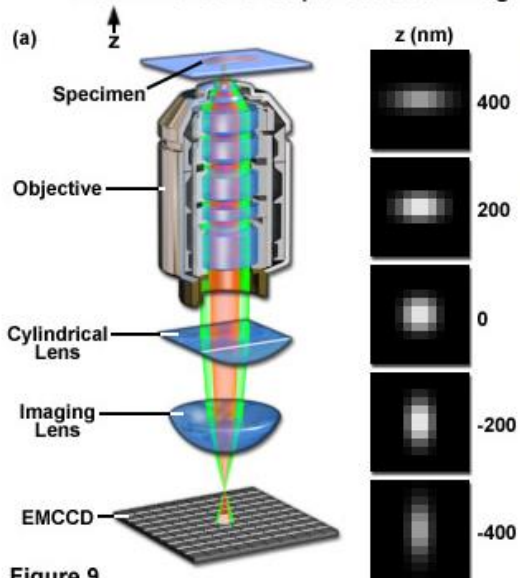
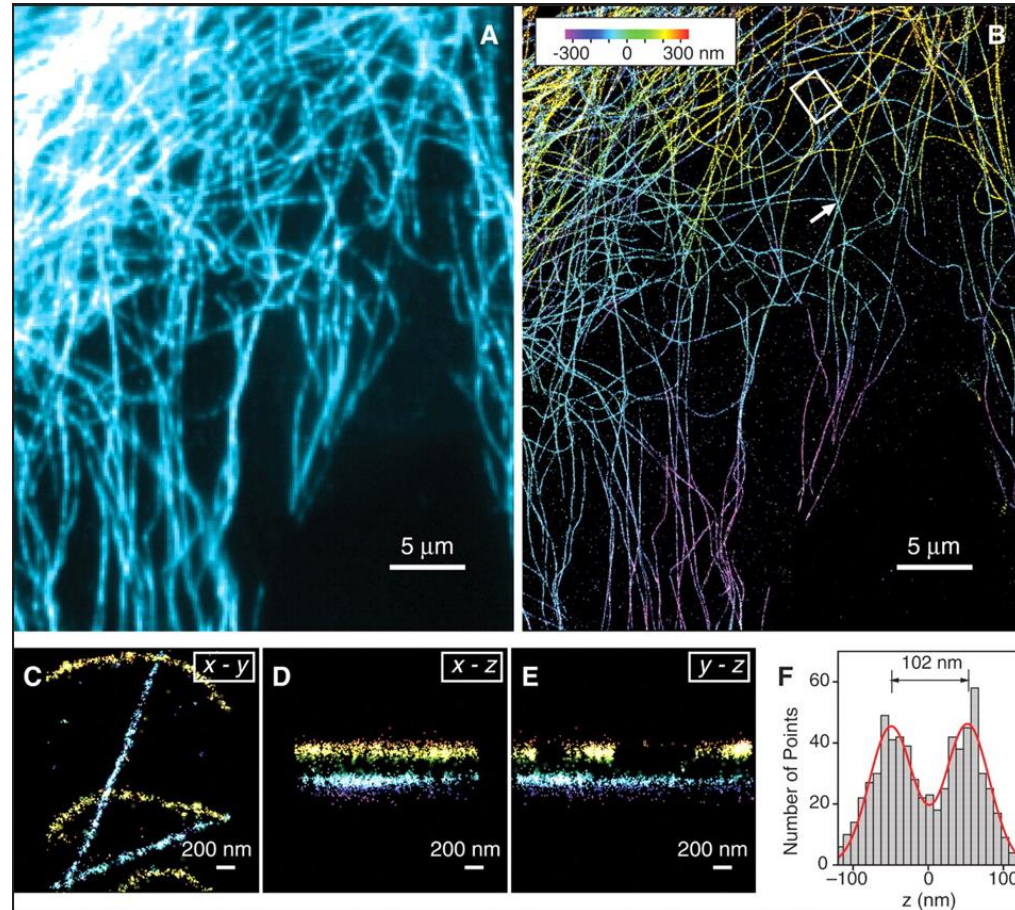
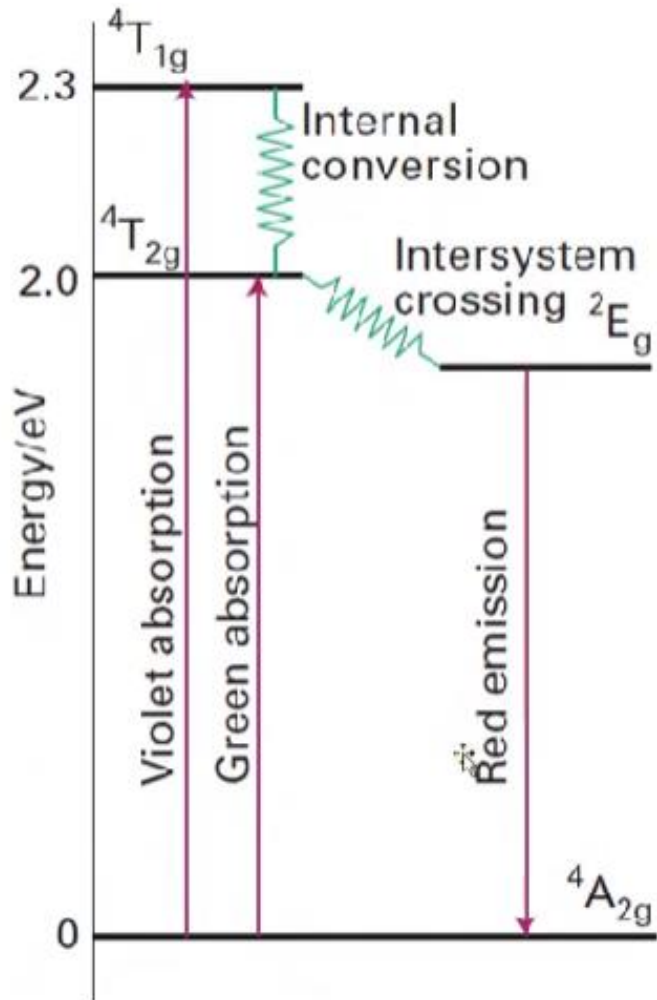

Figure 9



Fluorescence in ruby (some Al is substituted with Cr)



Ruby ($\text{Al}_2\text{O}_3:\text{Cr}$)

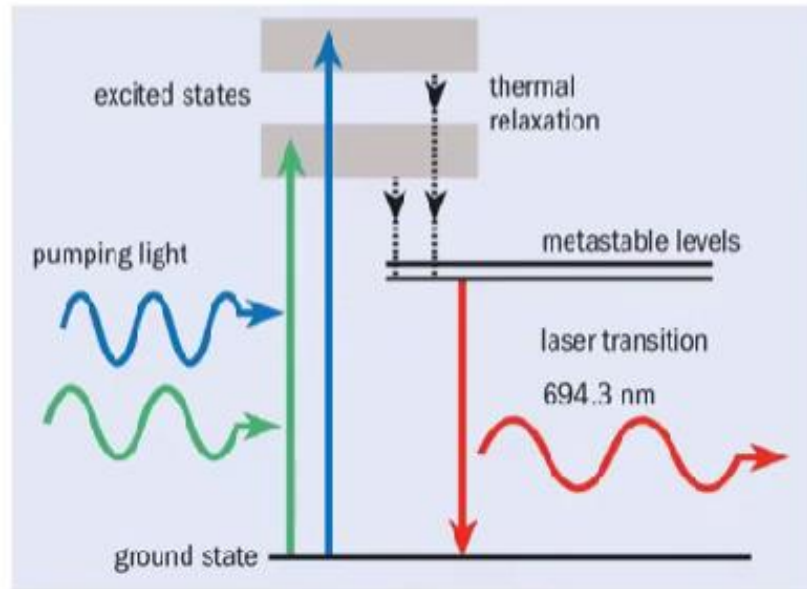
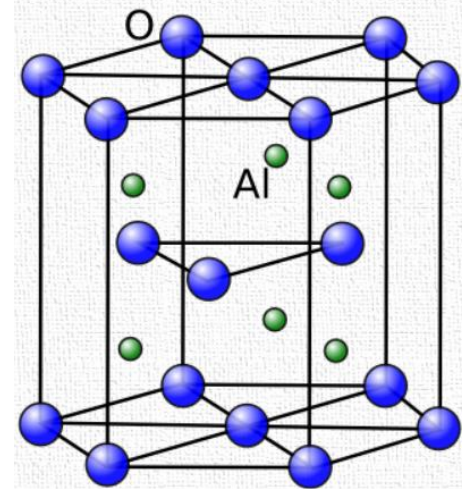

Absorption and luminescence of Cr^{3+} in ruby.

Fluorescence in ruby (some Al is substituted with Cr)

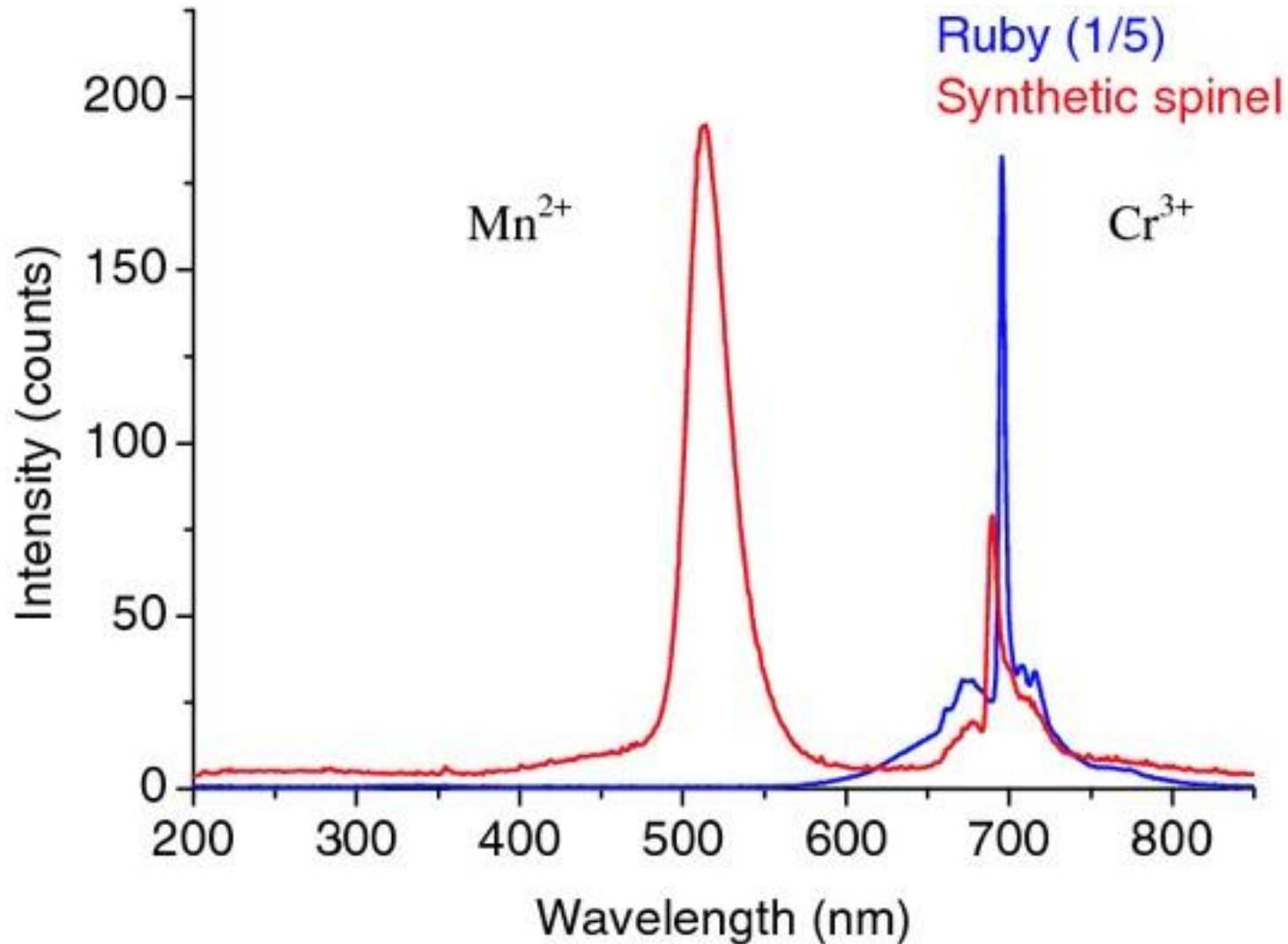

Time-Dependent Fluorescence: Fluorescence Lifetime

Fluorescence Lifetime: The average amount of time a molecule stays in excited state

Probability of being in the excited state

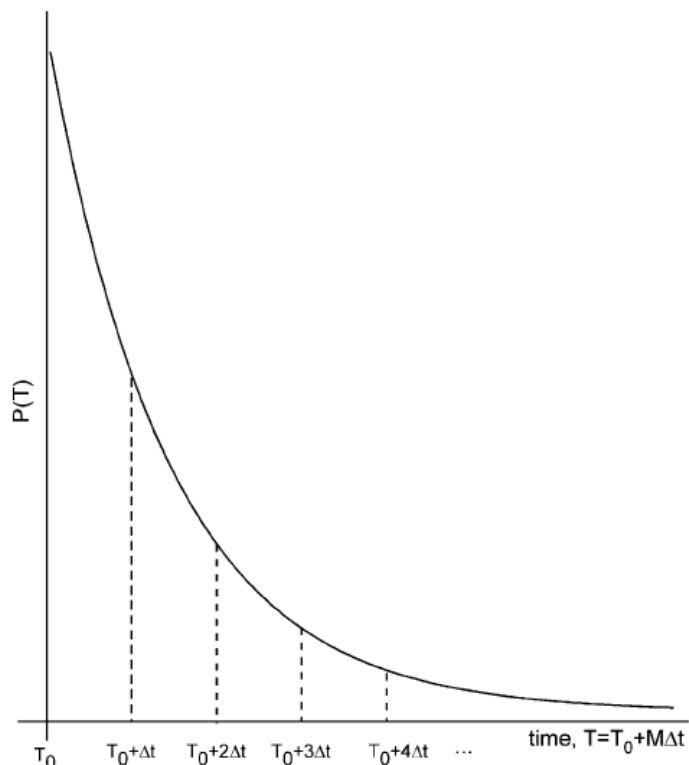

k_f = rate constant for leaving excited state while emitting a photon

k_i = rate constant for leaving excited state through other means (ie. Dynamic quenching, Energy Transfer, etc)

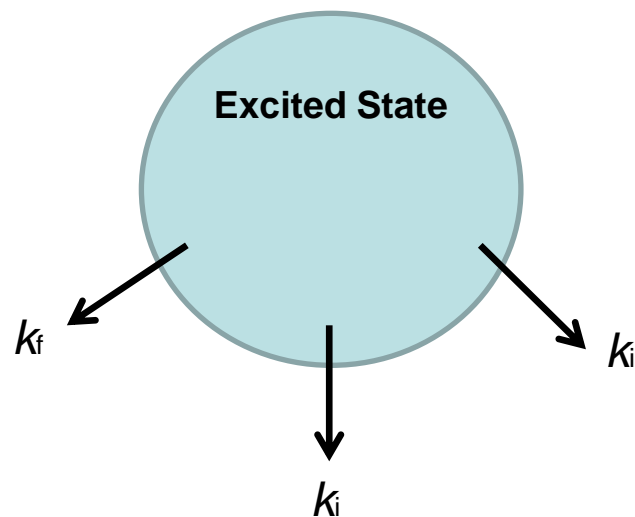

Fluorescence Lifetime: $\frac{1}{\tau} = \sum_i k_i$

Lifetime is sensitive to other decaying pathways present!

Lambert law

A common and practical expression of the Beer–Lambert law relates the optical attenuation of a physical material containing a single attenuating species of uniform concentration to the **optical path length** through the sample and **absorptivity** of the species. This expression is:

$$A = \epsilon \ell c$$

Where

- A is the **absorbance**
- ϵ is the **molar attenuation coefficient** or **absorptivity** of the attenuating species
- ℓ is the optical path length
- c is the **concentration** of the attenuating species

Absorbance is defined as "the logarithm of the ratio of incident to transmitted radiant power through a sample

Lambert law

History [\[edit \]](#)

The law was discovered by [Pierre Bouguer](#) before 1729, while looking at red wine, during a brief vacation in [Alentejo, Portugal](#).^[1] It is often attributed to [Johann Heinrich Lambert](#), who cited Bouguer's *Essai d'optique sur la gradation de la lumière* (Claude Jombert, Paris, 1729) – and even quoted from it – in his *Photometria* in 1760.^[2] Lambert's law stated that the loss of light intensity when it propagates in a medium is directly proportional to intensity and path length. Much later, the German scientist [August Beer](#) discovered another attenuation relation in 1852. Beer's law stated that the transmittance of a solution remains constant if the product of concentration and path length stays constant.^[3] The modern derivation of the Beer–Lambert law combines the two laws and correlates the absorbance, which is the negative decadic logarithm of the transmittance, to both the concentrations of the attenuating species and the thickness of the material sample.^[4] The first modern formulation was given possibly by Robert Luther and Andreas Nikolopoulos in 1913.^[5]

Lambert law

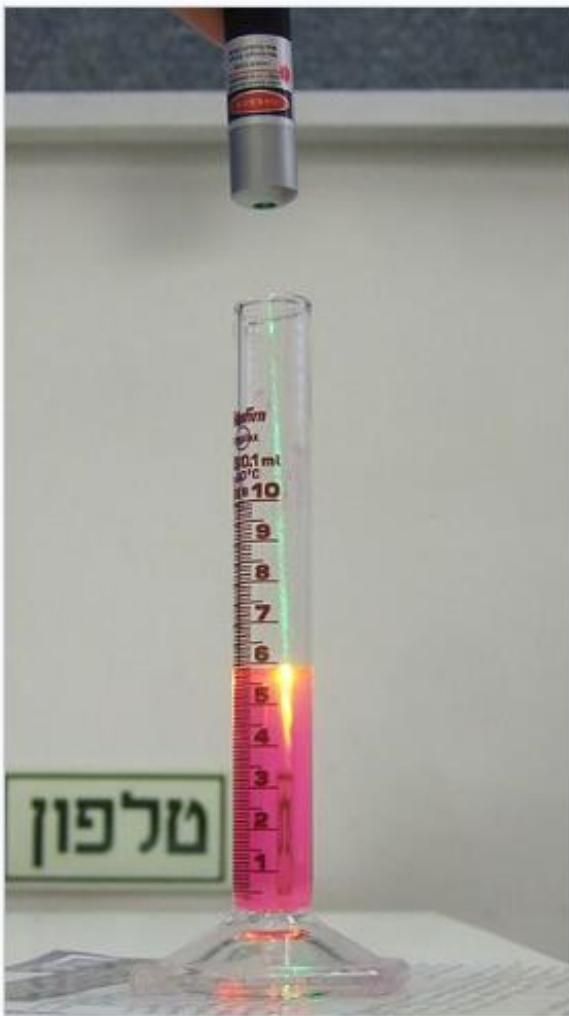

A demonstration of the Beer–
Lambert law: a beam of green laser
light passes through a solution of
[Rhodamine 6B](#). The beam's radiant
power becomes weaker as it passes
through solution.



Beer-Lambert's Law

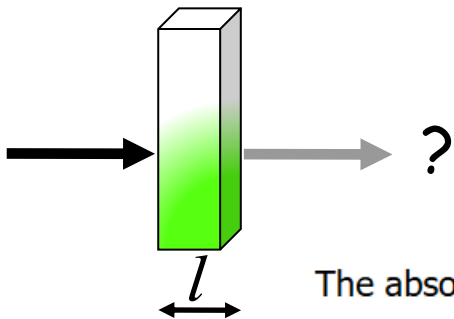

The absorbance (A) is defined via the incident intensity I_o and transmitted intensity I by

$$A = \log_{10} \left(\frac{I_o}{I} \right)$$

$$\log(I_o) - \log(I) = \epsilon c l$$

Extinction coefficient:

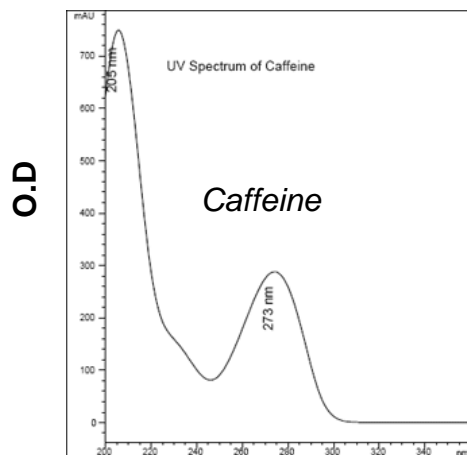

Concentration

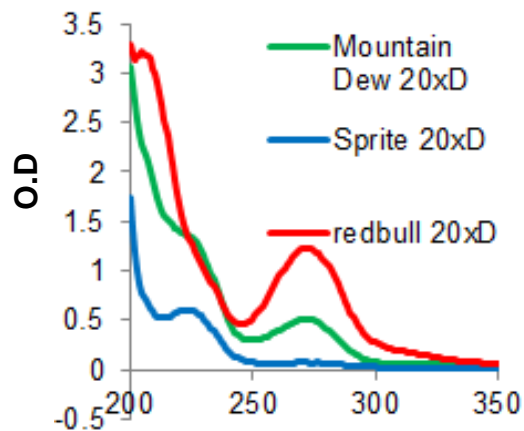

The Bolognian Stone

http://www.isbc.unibo.it/Files/10_SE_BoStone.htm

The Bologna Stone was discovered in 1603, at the base of a dead volcano near Bologna. When treated with heat, and exposed to sunlight, it would glow for hours—sometimes days. It took 400 years to figure out why. In 1603, Vincenzo Cascariolo was digging in the volcanic rock near Bologna, Italy. The man was a shoemaker by trade, but he hoped to get rich by alchemy. When he found a milky-white stone he decided to take some samples back to his workshop. There, he most likely heated a sample of the stone, possibly in a special oven that let him control the exposure of the material to both the source of heat (coals or flames) and the oxygen in the air. The process is called “calcination.” Cascariolo failed to come up with the Philosopher’s Stone, but he can’t be faulted for thinking he did. After all, after the treatment, if exposed to sunlight or flames this particular stone glowed in the dark for hours.



Marc Antonio Cellio (1680) representing the light emission of heated barite

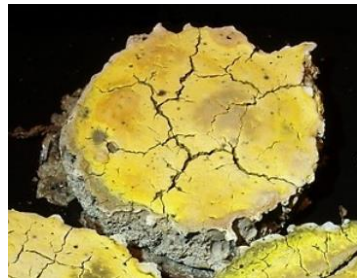

<https://www.flickr.com/photos/28617364@N04/sets/72157635506831648/>

[Here's someone who made “Bologna stone pies.”](#) by adding, among other things, copper chloride to barium sulfate and baked the result.

It took scientists a long time to figure out what it was that made baryte glow the way it did. Over four centuries after its discovery, [scientists took a lab to samples](#) of the Bologna Stone. What they found was an impurity in the baryte. Copper ions, denuded of two electrons each, were sprinkled through the baryte. When exposed to light, they would absorb energy, and then slowly emit it over multiple days.

<https://gizmodo.com/the-bologna-stone-was-a-glowing-mystery-for-400-years-1724589932>



It is now a long time since the cobbler of Bologna, in Italy, astonished and amused his friends with a peculiar substance since known as *Bologna phosphorus*, *Bologna stone*, or *Solar phosphorus*, which shines brightly in the dark after having been placed in the sunlight for some time. This substance is sulphuret of barium. The cobbler prepared it by heating red-hot with charcoal a piece of *sulphate of baryta*, or *Barytine*, (Fig. 1,) a stone which he



Fig. 1.

picked up in the secondary strata of the Monte Paterno, where he found it in lumps of considerable weight.* The German chemist, Marggraf, used to prepare solar phosphorus by powdering down the stone, and making it into thin cakes, with a mixture of flour and water, before submitting it to calcination. This "Bologna phosphorus" was the first substance known to become phosphorescent after insolation, and, consequently, it has been

1870.

T. L. PHIPSON, PH.D., F.C.S.

submitted to many and varied experiments. It is best obtained by the calcination of pulverized sulphate of baryta, made into a firm paste with common gum. It should be preserved in a bottle which closes hermetically with a glass stopper.

It will be easily understood what is meant by the term *Phosphorescence*, when we remind our readers that phosphorus, which shines so curiously in the dark, and which enters into the composition of our common lucifer matches, is the most remarkable of all phosphorescent bodies. The word "phosphorus," which signifies a substance that bears or emits a light, has frequently been applied to various other substances besides the non-metallic element termed *phosphorus* in chemistry, on account of the property these substances possess likewise of shining in the dark.

First mention of lifetimes?

"The Bologna stone, when placed in the sun attracts the rays, and retains them so long as to give light a considerable time after it is removed into the dark." *Goethe "The Sorrows of Werter"*

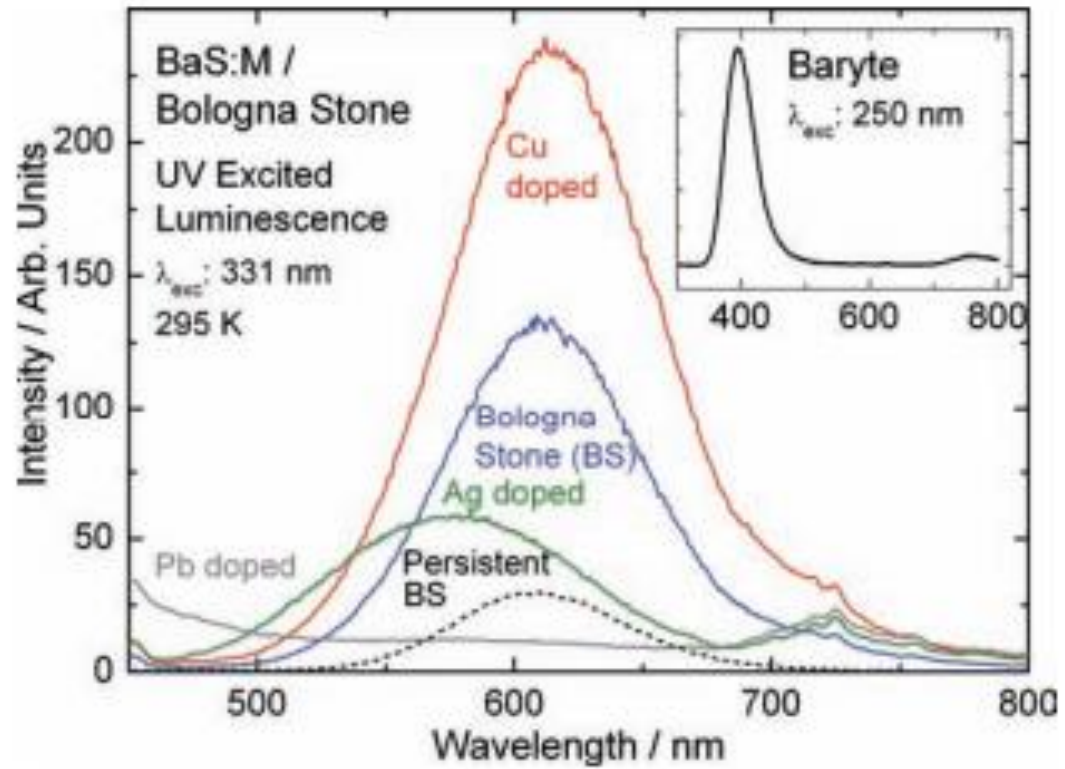

Lastusaari et al. 2011

Dr. Brand in 1674-5 attempted to distil human urine and in this way discovered phosphorus.

Phosphorus (Greek phosphoros was the ancient name for the planet Venus) was discovered by German alchemist Hennig Brand in 1669 through a preparation from urine. Working in Hamburg, Brand attempted to distill salts by evaporating urine, and in the process produced a white material that glowed in the dark and burned brilliantly.



Misnomer:
Phosphorescence
of phosphorous is
due to slow
oxidation

Painting by Joseph Wright of Derby (18th century) representing the discovery of the "phosphorescence" of the phosphorus extracted from urine by Hennig Brand in 1669

Measuring the Depletion of the excited state

$$[\# x^*] = [\# x_o^*] e^{-(k_F + k_t)t}$$

$$[\# x^*](k_F) = \text{Intensity that you measure}$$

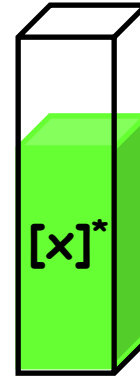

k_F is rate constant of fluorescence

Intensity measured is proportional to the # of molecules in the excited state!

Measuring Lifetime: Time Domain

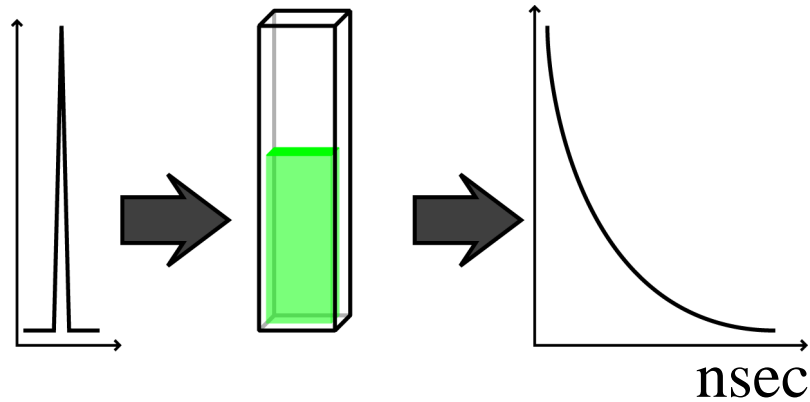

What do you need?

- Collect signal fast enough
- Fitting

Measuring Lifetime: Frequency Domain

$$E(t) = E_o + E_\omega \cos(\omega_E t + \varphi_E)$$

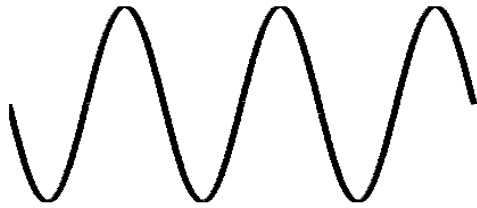

$$F(t) = F_o + F_\omega \cos(\omega_E t + \varphi_E - \varphi)$$

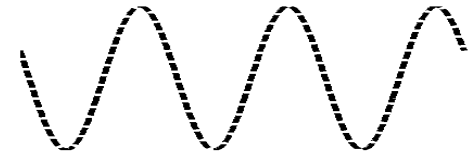

$$\tan(\varphi) = \omega_E \tau_\varphi$$

$$M = \frac{F_\omega / F_o}{E_\omega / E_o} = \frac{1}{\sqrt{1 + (\omega \tau_{Mod})^2}}$$

What do you need?

-Intensity modulators

-Synchronization

AOMs - Intensity Modulator

MEASUREMENTS OF SUBNANOSECOND FLUORESCENCE LIFETIMES WITH A CROSS-CORRELATION PHASE FLUOROMETER*

Richard D. Spencer and Gregorio Weber
 Department of Chemistry and Chemical Engineering
 University of Illinois
 Urbana, Ill.

Annals of the New York Academy of Sciences Vol. 158 pp 361-376, 1969

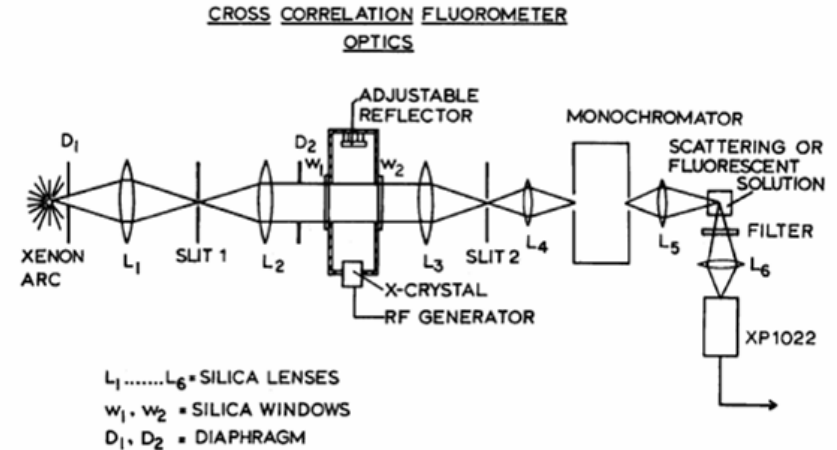

FIGURE 4. Plan of the optics of fluorometer.

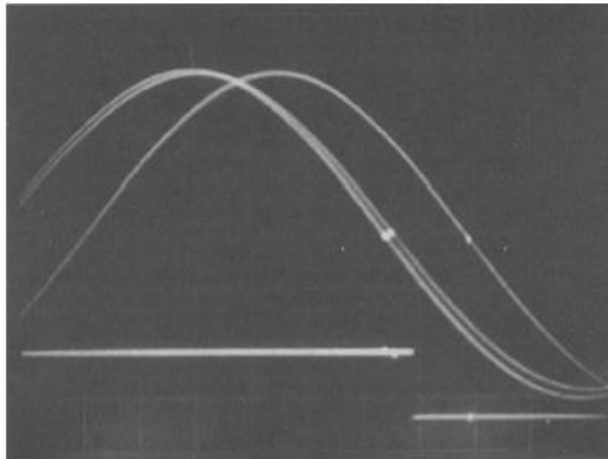

FIGURE 7. The figure shows the cross-correlation photocurrents from a scattering solution (first from left), a solution of NADH in phosphate buffer, pH 7.0, 17° C (second from left), and a solution of fluorescein (1 μgm/ml) in 0.01 M NaOH (right).

-modulation frequency limited by resonance frequency of the acousto-optic cell

-variations in the intensity modulation caused by temperature

Champaign, IL: domain of fluorescence lifetime imaging microscopy

Robert Clegg - UIUC
Full-Field FLIM



Enrico Gratton - UIUC
Scanning Confocal FLIM (FLIMBox)



Beniamino Barbieri - ISS Inc.
Commercialization of FD FLIM



Applications of Fluorescence in Biology

Fluorescence Lifetime Imaging on Live Cells

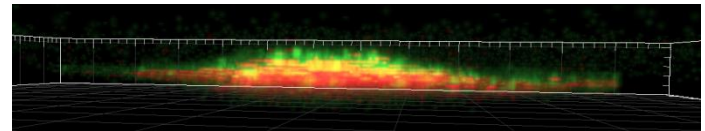
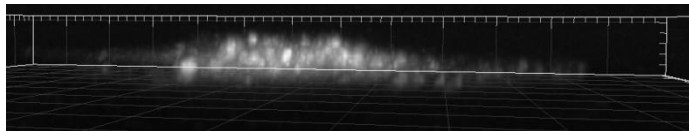
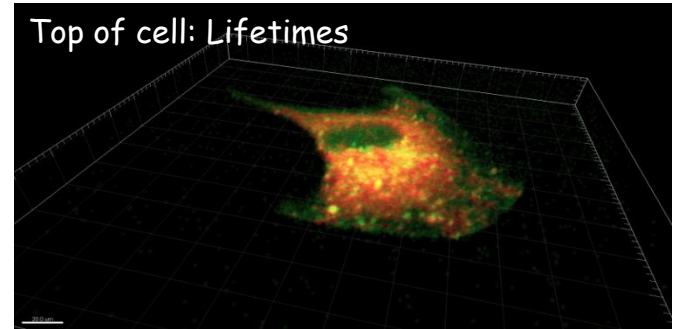
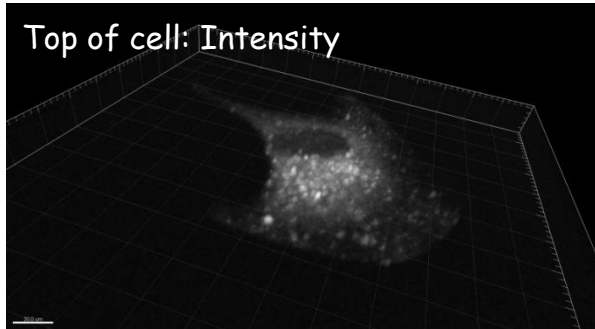

Optical Sections - Rendered by Lifetime

