

Physics 513

Topics in Quantum Optics and
Quantum Information

The Quantum Information Revolution

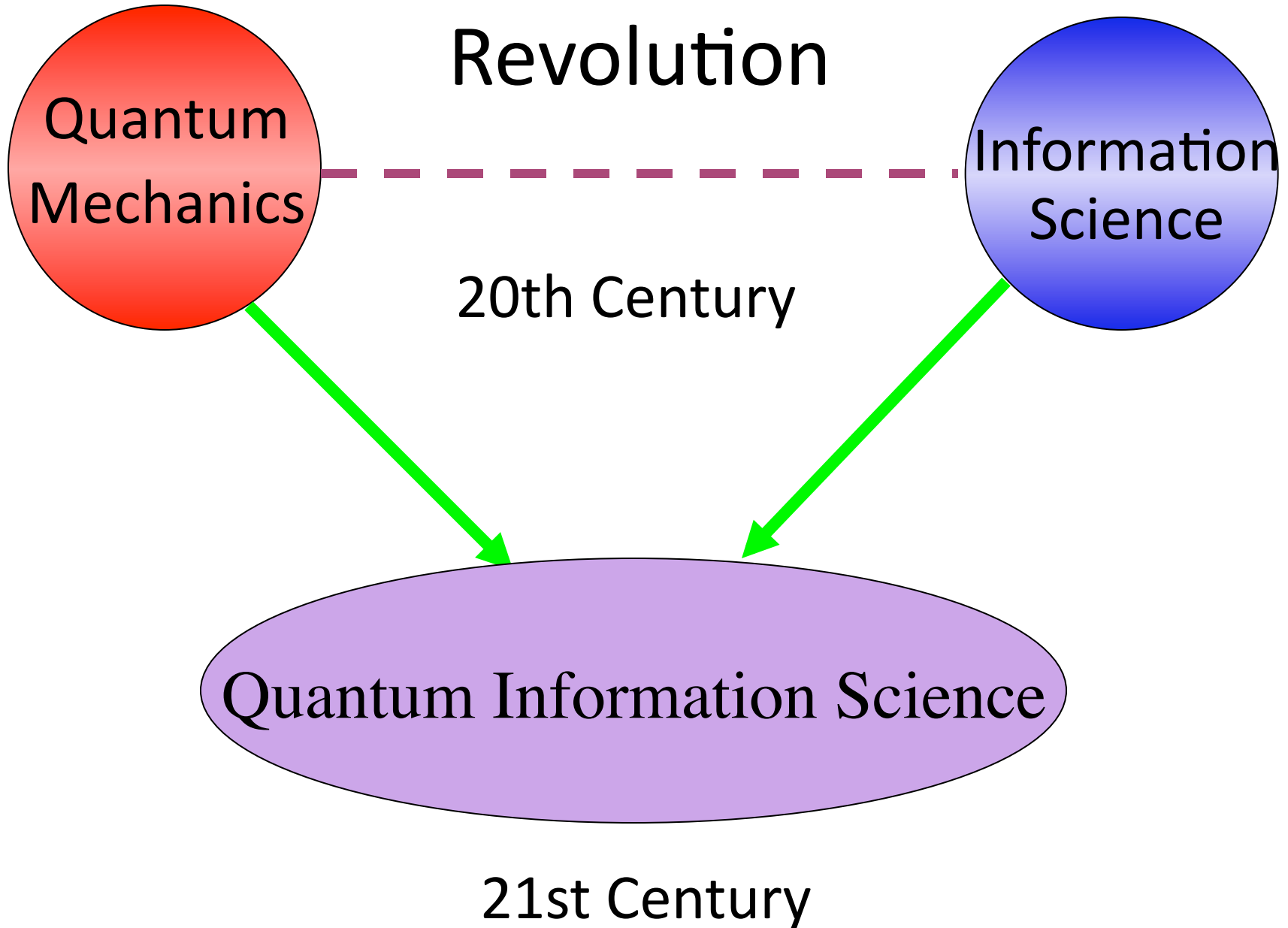

No small effort

Estimated annual spending on non-classified quantum-technology research, 2015, €m

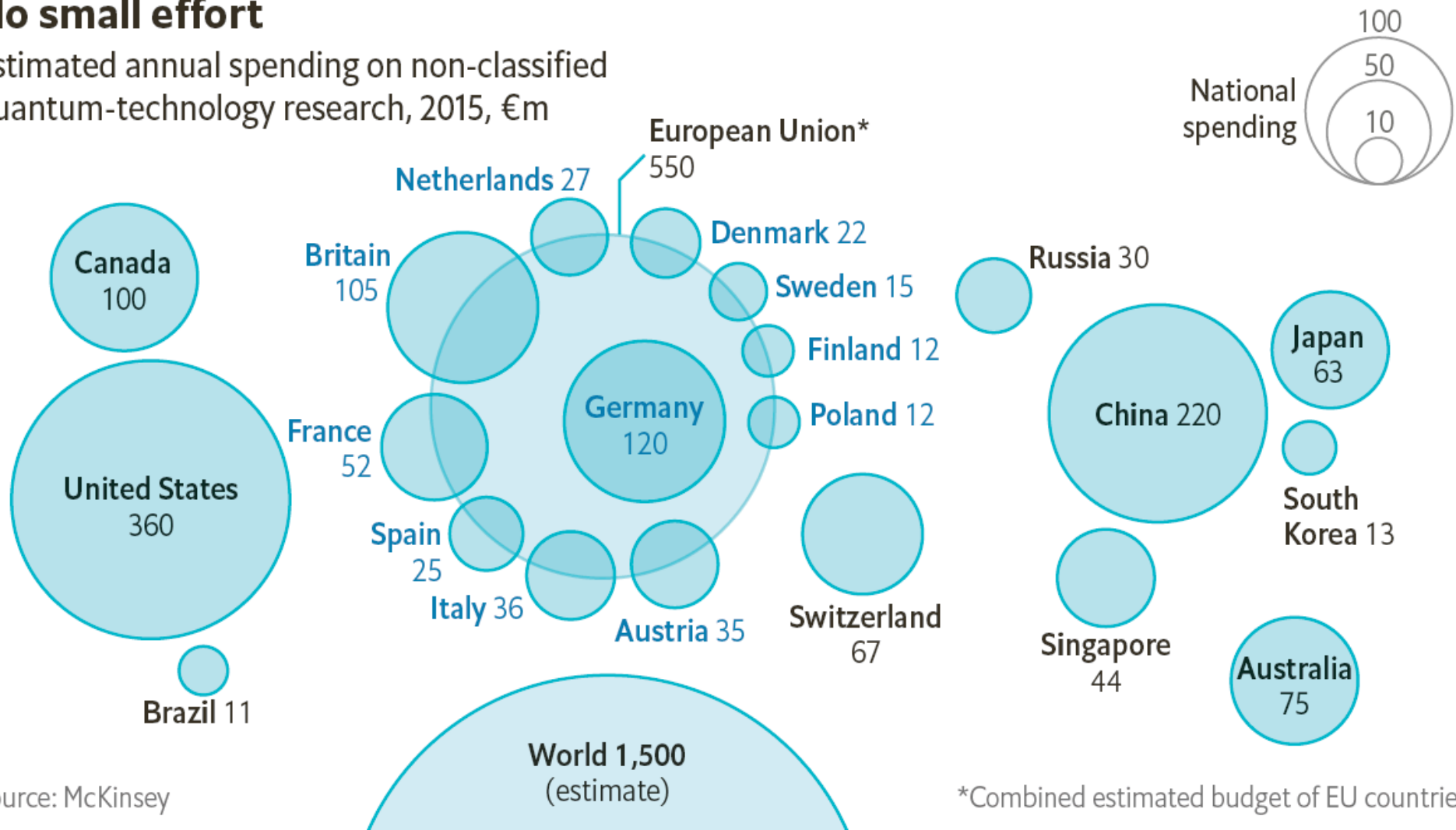

Source: McKinsey

H.R.6227 - National Quantum Initiative Act

115th Congress (2017-2018)

LAW

Hide Overview ✕

Sponsor: [Rep. Smith, Lamar \[R-TX-21\]](#) (Introduced 06/26/2018)

Committees: House - Science, Space, and Technology | Senate - Commerce, Science, and Transportation

Committee Reports: [H. Rept. 115-950](#)

Latest Action: 12/21/2018 Became Public Law No: 115-368. ([All Actions](#))

Roll Call Votes: There has been [1 roll call vote](#)

Tracker:

Introduced > Passed House > Passed Senate > Resolving Differences > To President > **Became Law**

This bill directs the President to implement a National Quantum Initiative Program to, among other things, establish the goals and priorities for a 10-year plan to accelerate the development of quantum information science and technology applications.

The bill defines "quantum information science" as the storage, transmission, manipulation, or measurement of information that is encoded in systems that can only be described by the laws of quantum physics.

The National Science and Technology Council shall establish a Subcommittee on Quantum Information Science, including membership from the National Institute of Standards and Technology (NIST) and the National Aeronautics and Space Administration (NASA), to guide program activities.

The President must establish a National Quantum Initiative Advisory Committee to advise the President and subcommittee on quantum information science and technology research and development.

NIST shall carry out specified quantum science activities and convene a workshop to discuss the development of a quantum information science and technology industry.

The National Science Foundation shall:

- carry out a basic research and education program on quantum information science and engineering, and
- award grants for the establishment of Multidisciplinary Centers for Quantum Research and Education.

The Department of Energy (DOE) shall carry out a basic research program on quantum information science.

The Office of Science of DOE shall establish and operate National Quantum Information Science Research Centers to conduct basic research to accelerate scientific breakthroughs in quantum information science and technology.



IQUIST:

Illinois

**QUantum
Information
Science and
Technology
Center**

I ILLINOIS

IQUIST

New center to accelerate quantum information science and engineering

OCT 29, 2018 10:00 AM

BY NEWS BUREAU

CAMPUS

- \$15 M investment
- ≥ 8 new faculty
- Currently searching in
 - Physics (experimental)
 - Electrical and Computer Engineering
 - Computer Science
- Fourth/final core member of Chicago Quantum Exchange



Quote(s) of the Day:

R. P. Feynman:

“One great simplification is this – that an electron behaves just like light. That is, the quantum behavior of these things – electrons, and photons, and so on – are the same.”

A. Einstein:

“These days every Tom, Dick and Harry thinks he knows what a photon is, but he is wrong!”

Europhys. Lett., 1 (4), pp. 173-179 (1986)

Experimental Evidence for a Photon Anticorrelation Effect on a Beam Splitter: A New Light on Single-Photon Interferences.

P. GRANGIER, G. ROGER and A. ASPECT (*)

Institut d'Optique Théorique et Appliquée, B.P. 43 - F 91406 Orsay, France

Abstract. – We report on two experiments using an atomic cascade as a light source, and a triggered detection scheme for the second photon of the cascade. The first experiment shows a strong anticorrelation between the triggered detections on both sides of a beam splitter. This result is in contradiction with any classical wave model of light, but in agreement with a quantum description involving single-photon states. The same source and detection scheme were used in a second experiment, where we have observed interferences with a visibility over 98%.

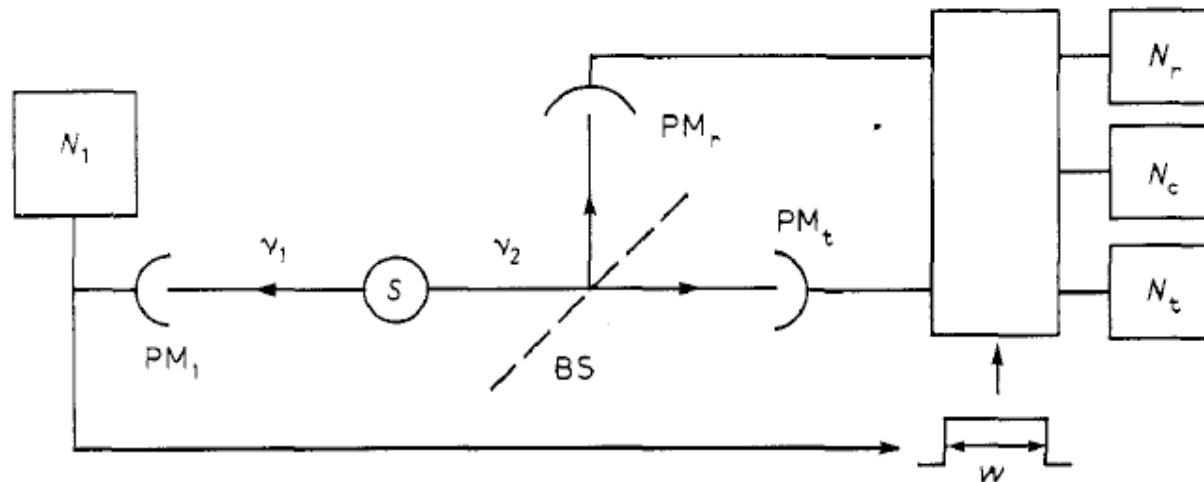

$$\alpha \equiv \frac{N_{1rt} N_1}{N_{1r} N_{1t}}$$

Calculate α for semiclassical fields:

$$\alpha \equiv \frac{N_{1r}N_1}{N_{1r}N_{1t}}$$

Let $I_1(t)$ = intensity of optical disturbance going to left

$I(t)$ = intensity of optical disturbance going to right

$I_r(t)$ = intensity going to detector r ; $I_t(t)$ \rightarrow detector t

$\overline{I(t)}$ \equiv time average

$$N_1 \propto \eta_1 \overline{I_1}$$

$$N_{1r} \propto \eta_1 \eta_r \overline{I_1 I_r} = \eta_1 \eta_r \frac{\overline{I_1 I}}{2} \quad (1/2 \text{ from beamsplitter})$$

$$N_{1t} \propto \eta_1 \eta_t \overline{I_1 I_t} = \eta_1 \eta_t \frac{\overline{I_1 I}}{2}$$

$$N_{1rt} \propto \eta_1 \eta_r \eta_t \overline{I_1 I_r I_t} = \eta_1 \eta_r \eta_t \frac{1}{4} \overline{I_1 I^2}$$

$$\text{Let } f \equiv \sqrt{I_1 I}, \quad g \equiv \sqrt{I_1} \quad \Rightarrow \alpha = \frac{\overline{f^2 g^2}}{(\overline{fg})^2}$$

$$\therefore \alpha = \frac{\left(\frac{1}{4} \eta_1 \eta_r \eta_t \overline{I_1 I^2} \right) \eta_1 \overline{I_1}}{\left(\frac{1}{2} \eta_1 \eta_r \overline{I_1 I} \right) \left(\frac{1}{2} \eta_1 \eta_t \overline{I_1 I} \right)} = \frac{\overline{I_1 I^2} \overline{I_1}}{(\overline{I_1 I})^2}$$

But $(\overline{f^2})(\overline{g^2}) \geq (\overline{fg})^2$ (Cauchy-Schwartz Inequality)

$$\therefore \alpha_{\text{semi-classical}} \geq 1 \quad (= 1 \text{ for coherent state})$$

$$\text{Proof: } \overline{fg} = \int dr P(r) f(r) g(r) = \int dr \left[A \equiv \sqrt{P(r)} f(r) \right] \left[B \equiv \sqrt{P(r)} g(r) \right] = (A, B)$$

$$\overline{f^2} = \int dr \sqrt{P(r)} f(r) \sqrt{P(r)} f(r) = (A, A) \quad \overline{g^2} = (B, B)$$

$$(A, A)(B, B) \geq (A, B)^2$$

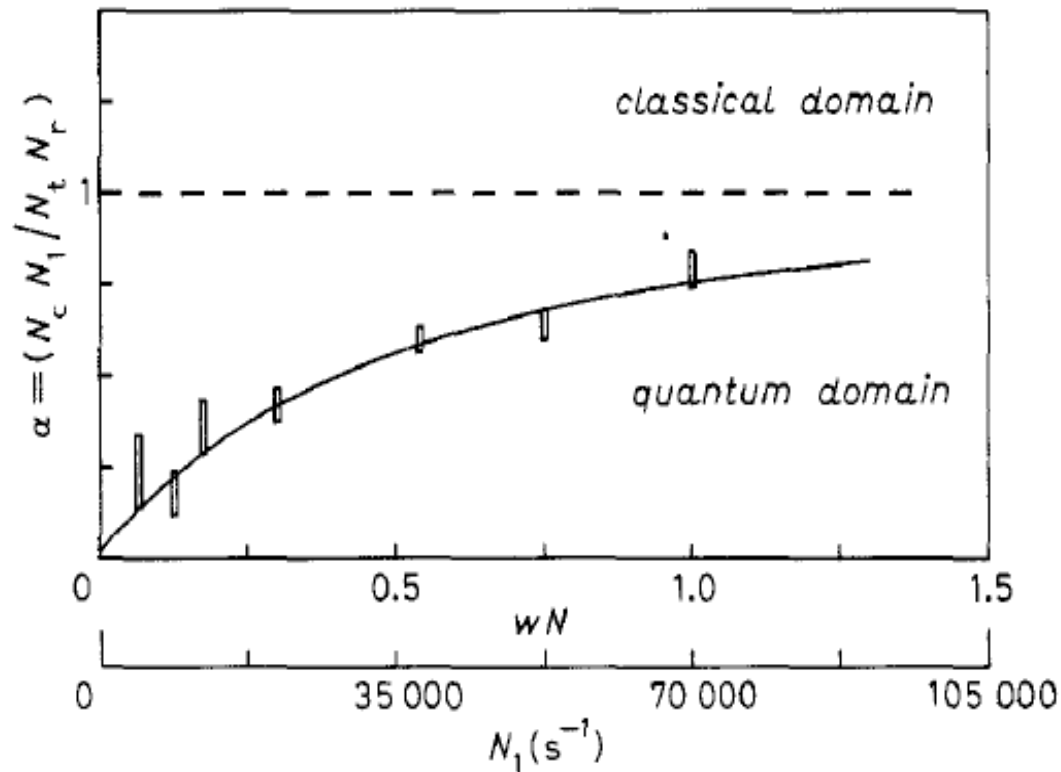

Fig. 2. - Anticorrelation parameter α as a function of wN (number of cascades emitted during the gate) and of N_1 (trigger rate). The indicated error bars are \pm one standard deviation. The full-line curve is the theoretical prediction from eq. (8). The inequality $\alpha \geq 1$ characterizes the classical domain.

Achieved $\alpha = 0.18 \pm 0.06$
 (limited by accidental coincidences)

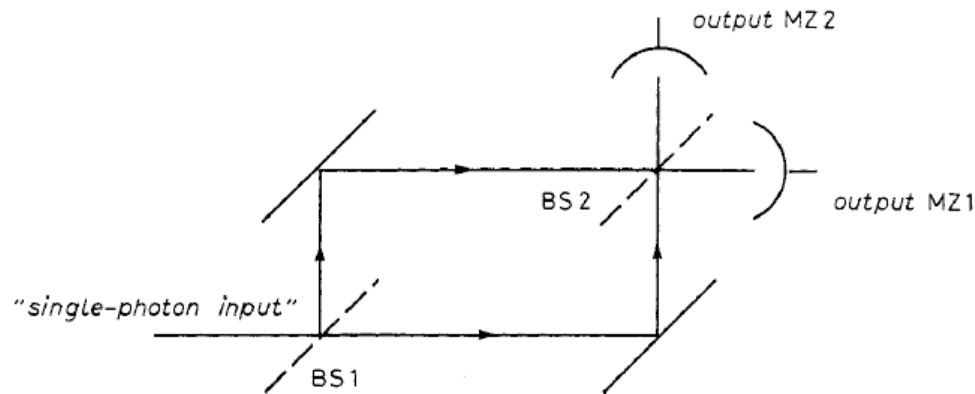

Fig. 3. – Mach-Zehnder interferometer. The detection probabilities in outputs MZ1 and MZ2 are oppositely modulated as a function of the path difference between the arms of the interferometer.

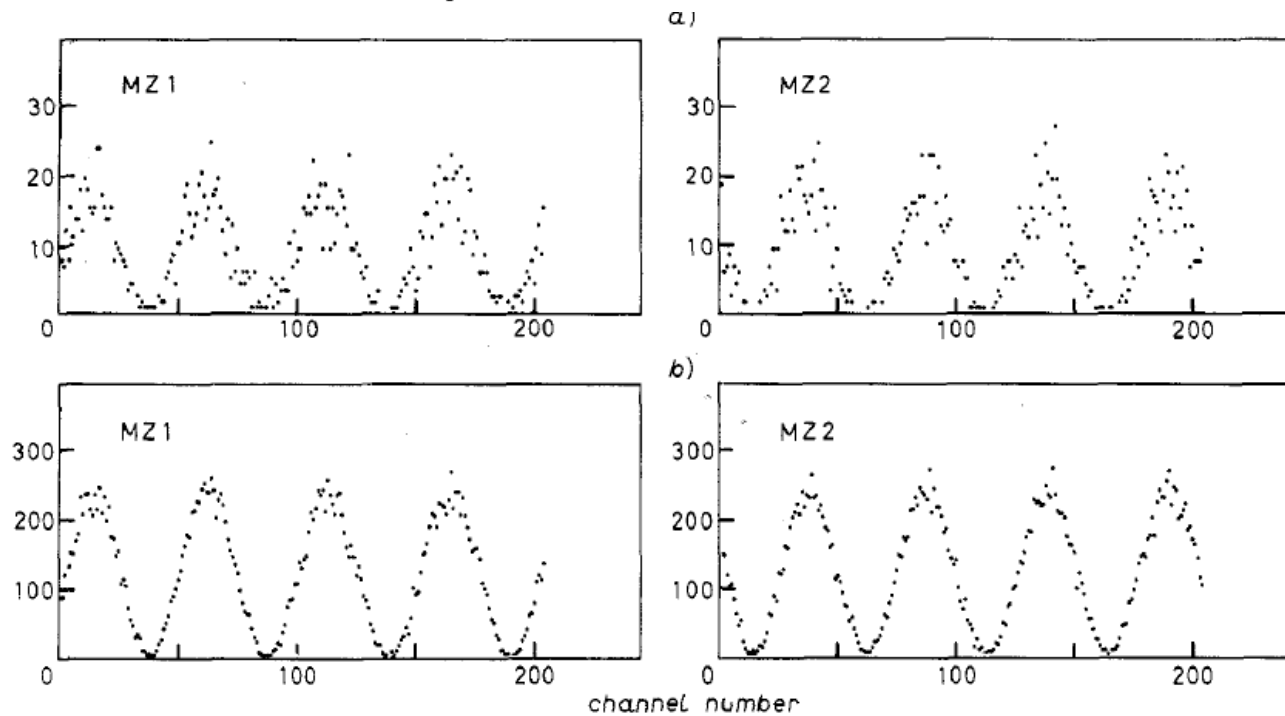

Fig. 4. – Number of counts in outputs MZ1 and MZ2 as a function of the path difference δ (one channel corresponds to a $\lambda/50$ variation of δ). a) 1 s counting time per channel b) 15 s counting time per channel (compilation of 15 elementary sweeps (like (a))). This experiment corresponds to an anticorrelation parameter $\alpha = 0.18$.

Foreshadowing....

From the point of view of quantum optics, we will rather emphasize that we have demonstrated a situation with some properties of a «single-photon state». An ideal source of such states would involve the collection of the light at frequency ν_2 in a 4π solid angle, and a shutter triggered by the photons ν_1 . One could then carry out many experiments related to nonclassical properties of light, for instance production of sub-Poisson light [12] (⁵).

Although such a scheme can be considered, it would be extremely hard to work out, for practical reasons. Nevertheless, there exists a similar scheme that seems more promising: it consists of pairs of photons emitted in parametric splitting [2, 13, 14]. Due to the phase matching condition, the angular correlation between photons ν_1 and ν_2 is very strong and it becomes possible to produce single-photon states in a single spatial mode.

Delayed-choice experiments in quantum interference

T. Hellmuth, H. Walther, A. Zajonc,* and W. Schleich

Sektion Physik, Universität München, D-8046 Garching, Federal Republic of Germany

and Max-Planck-Institut für Quantenoptik, D-8046 Garching bei München, Federal Republic of Germany

(Received 1 October 1986)

Following a suggestion by Wheeler, we have performed delayed-choice experiments in both the spatial and time domains. For the first experiment we use a low-intensity Mach-Zehnder interferometer, and for the second the technique of quantum beats in time-resolved atomic fluorescence. The results obtained show no observable difference between normal and delayed-choice modes of operation, in agreement with the predictions of quantum mechanics.

Phys. Rev. A 35, 2532 (1987)

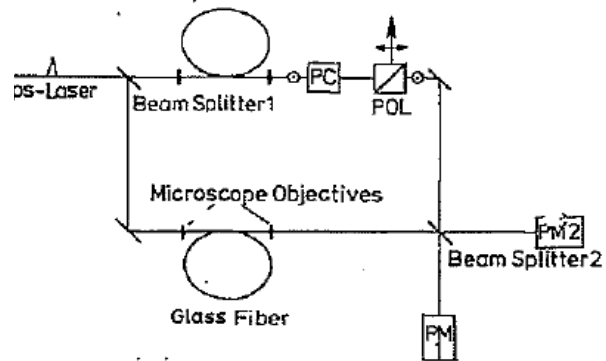
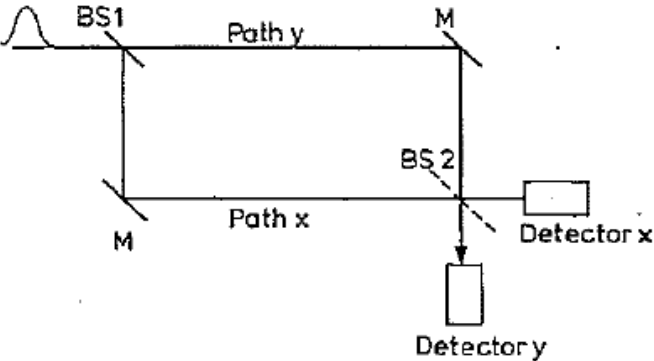

FIG. 3. Setup of the spatial-interference experiment with Pockels cell (PC) and Glan prism polarizer (POL).

$\langle n \rangle = 0.2$ photons/pulse

on the first beam splitter. This experiment is, as Wheeler puts it, "evidence that the arriving photon came by both routes." In the alternate arrangement the second beam splitter is removed and thus the detectors indicate whether the photon has traveled along path x or y. As in the double-slit experiment it is impossible simultaneously to obtain path information and observe the interference. In the new delayed-choice version of the experiment one decides according to Wheeler "whether to put in the second beam splitter or take it out at the very last minute. Thus one decides whether the photon shall have come by one route, or by both routes after it has already done its travel."

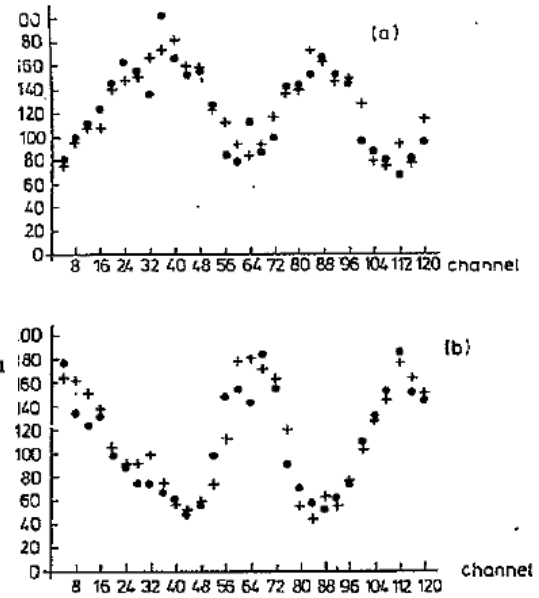

FIG. 6. Comparison of interference patterns for normal and delayed-choice configurations. Dots represent the data taken with the interferometer in its normal configuration, and crosses are data for delayed-choice operation. (a) is for photomultiplier 1, while the phase-inverted signal detected by photomultiplier 2 is shown in (b). The points are four-channel averages of the raw data. The horizontal axis is equivalent to time with 30 s/channel.

Experimental Realization of Wheeler's Delayed-Choice Gedanken Experiment

16 FEBRUARY 2007

Vincent Jacques,¹ E Wu,^{1,2} Frédéric Grosshans,¹ François Treussart,¹ Philippe Grangier,³ Alain Aspect,³ Jean-François Roch^{1*}

Wave-particle duality is strikingly illustrated by Wheeler's delayed-choice gedanken experiment, where the configuration of a two-path interferometer is chosen after a single-photon pulse has entered it: Either the interferometer is closed (that is, the two paths are recombined) and the interference is observed, or the interferometer remains open and the path followed by the photon is measured. We report an almost ideal realization of that gedanken experiment with single photons allowing unambiguous which-way measurements. The choice between open and closed configurations, made by a quantum random number generator, is relativistically separated from the entry of the photon into the interferometer.

Fig. 2. Experimental realization of Wheeler's gedanken experiment. Single photons emitted by a single N-V color center are sent through a 48-m polarization interferometer, equivalent to a time of flight of about 160 ns. A binary random number 0 or 1, generated by the QRNG, drives the EOM voltage between $V = 0$ and $V = V_{\pi}$ within 40 ns, after an electronic delay of 80 ns. Two synchronized signals from the clock are used to trigger the single-photon emission and the QRNG. In the laboratory frame of reference, the random choice between the open and the closed configuration is made simultaneously with the entry of the photon

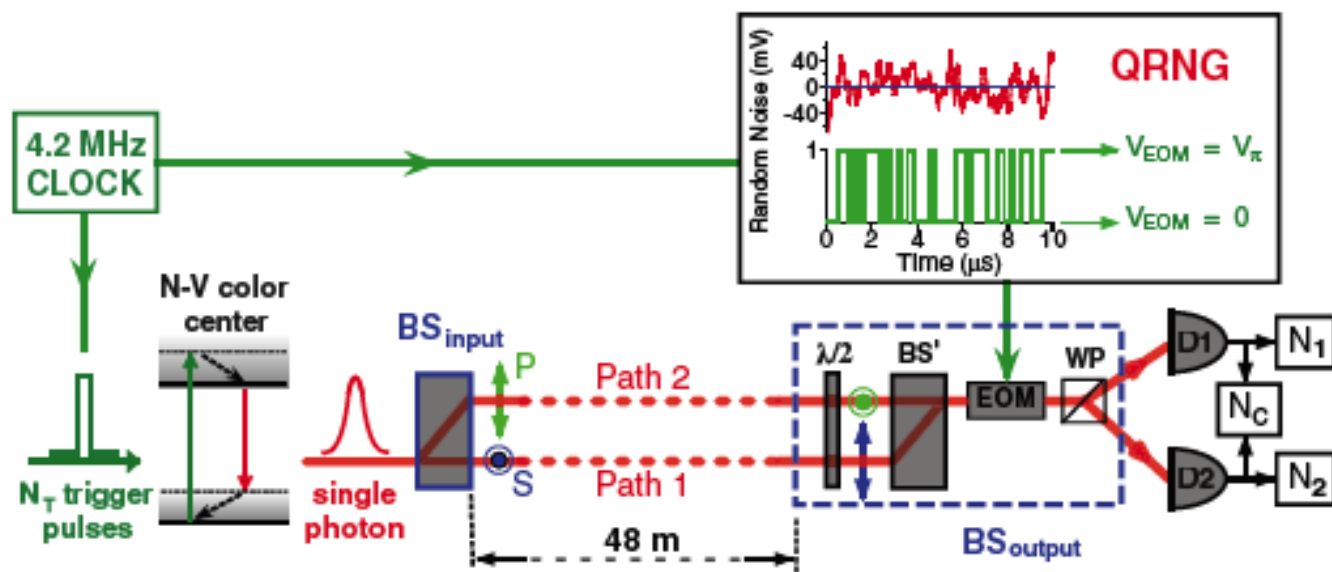

into the interferometer. Taking advantage of the fact that the QRNG is located at the output of the interferometer, such timing ensures that the photon enters the future light cone of the random choice when it is at about the middle of the interferometer, long after passing BS_{input} .

Fig. 3. Results of the delayed-choice experiment. The phase shift Φ (indicated with arbitrary origin) is varied by tilting BS'. Each point, recorded with acquisition time of 1.9 s, corresponds to the detection of about 2600 photons. The detector dark counts, 59 s^{-1} for D1 (blue points) and 70 s^{-1} for D2 (red points), have been subtracted from the data. (A) Cases when V_x is applied on the EOM (closed configuration); interference with 94% visibility is obtained. (B) Cases when no voltage is applied on the EOM (open configuration); no interference is observed and equal detection probabilities (0.50 ± 0.01) on the two output ports are measured, corresponding to full knowledge of the complementary which-way information (I parameter greater than 99%).

$\alpha = 0.12 \pm 0.01$
(limited by background
photoluminescence)

