

Statics - TAM 211

Lecture 14

October 19, 2018

Announcements

- Students are encouraged to practice drawing FBDs, writing out equilibrium equations, and solving these by hand using your calculator.
- Expending large amounts of time trying to de-bug MATLAB code, especially during a quiz, is not the focus of this course. All problems can be solved by hand. Quiz questions are timed for solution by hand.
- PrairieLearn incorrect software issues:
 - Negative sign symbol (- vs. –)
 - Space between negative sign (-12 vs. - 12)
 - Solutions:
 - Always type in the negative sign symbol (-) into your PL answers for HW or Quiz.
 - Do not add space between negative symbol and number
 - All students with these errors will be provided updated grades on Quiz 1. No credit for Quiz 2 and beyond.
- Upcoming deadlines:
 - Friday (10/19)
 - Written Assignment 4
 - Tuesday (10/23)
 - Prairie Learn HW5
 - Quiz 2 (10/24)
 - During class time (9:00 am)
 - Computer Lab (D211 for ME, D331 for CEE)
 - No class
 - Friday October 26 (Sports Meeting day)
 - Monday October 29

Chapter 5: Equilibrium of Rigid Bodies

Goals and Objectives

- Introduce the free-body diagram for a rigid body
- Develop the equations of equilibrium for a 2D and 3D rigid body
- Solve rigid body equilibrium problems using the equations of equilibrium in 2D and 3D

- Introduce concepts of
 - Support reactions for 2D and 3D bodies
 - Two- and three-force members
 - Constraints and statical determinacy

Recap: Equilibrium of a Rigid Body

Reduce forces and couple moments acting on a body to an equivalent resultant force and a resultant couple moment at an arbitrary point O .

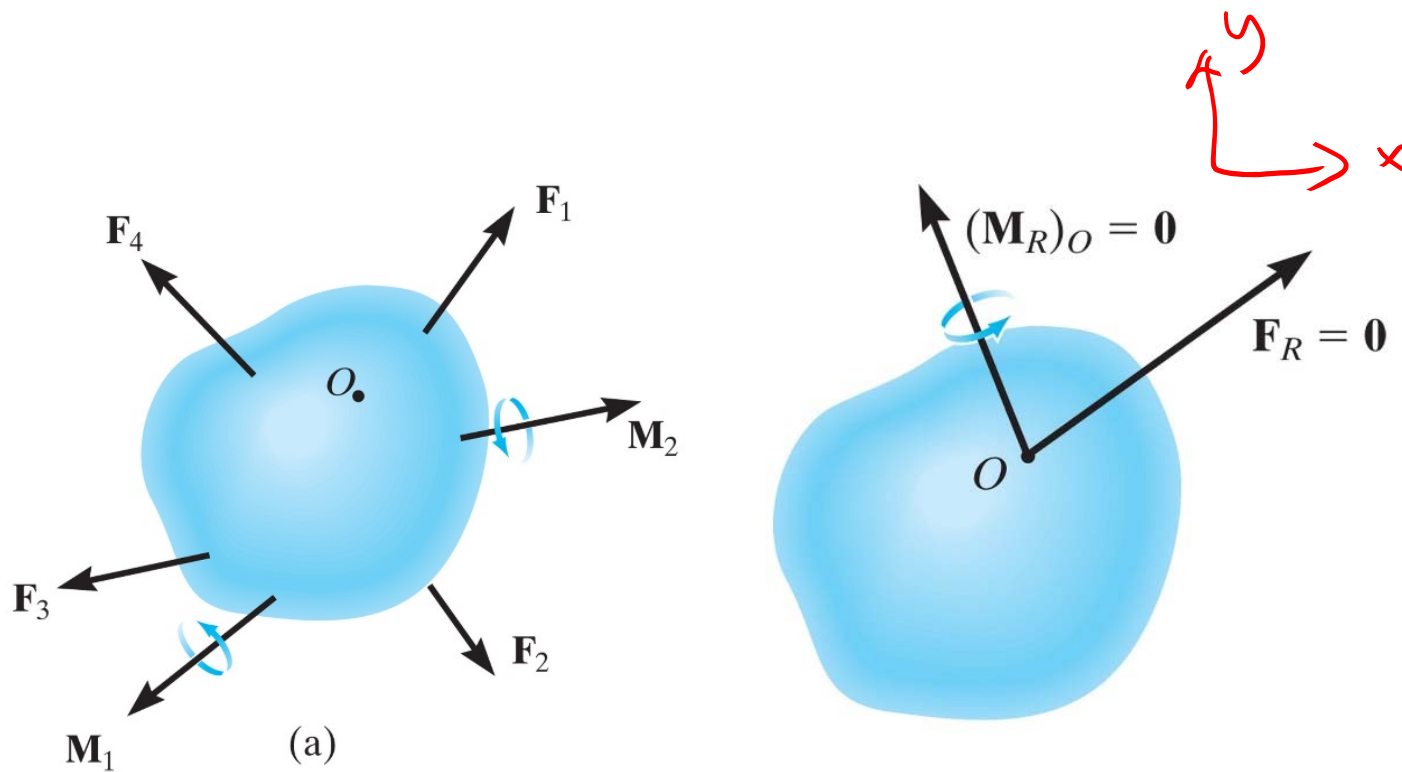

$$\sum \vec{F}_x = 0$$
$$\sum \vec{F}_y = 0$$

$$\vec{F}_R = \sum \vec{F} = \mathbf{0}$$

$$(\vec{M}_R)_O = \sum \vec{M}_O = \mathbf{0}$$

$$\rightarrow) \sum \vec{M}_O$$

Recap: Equilibrium in two-dimensional bodies (Support reactions)

Roller



Smooth pin or hinge



Fixed support

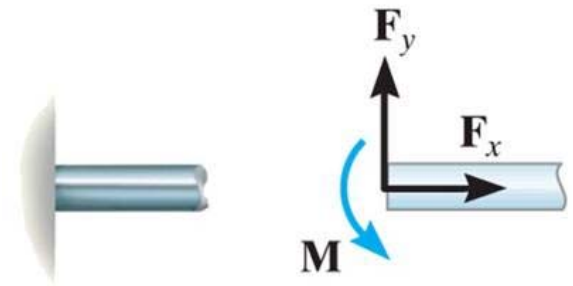
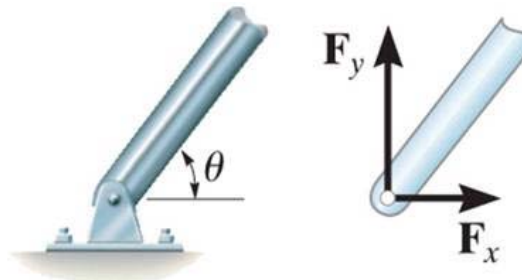
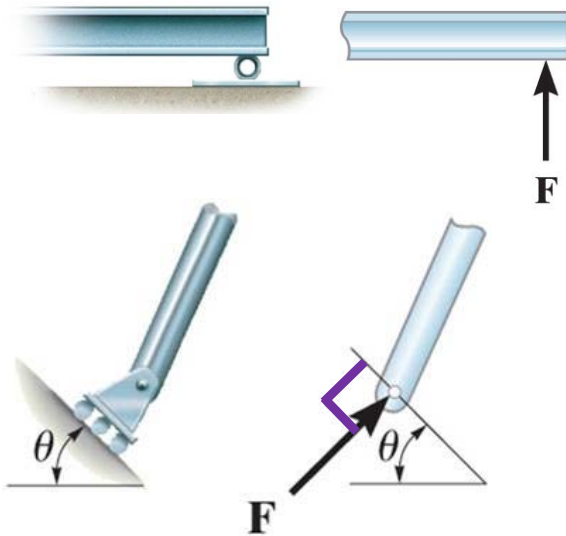

- If a support prevents the translation of a body in a given direction, then a force is developed on the body on that direction
- If a rotation is prevented, a couple moment is exerted on the body

Beam has mass of 100 kg and experiences load of 1200 N. Identify support reaction type. Find support reactions at A.

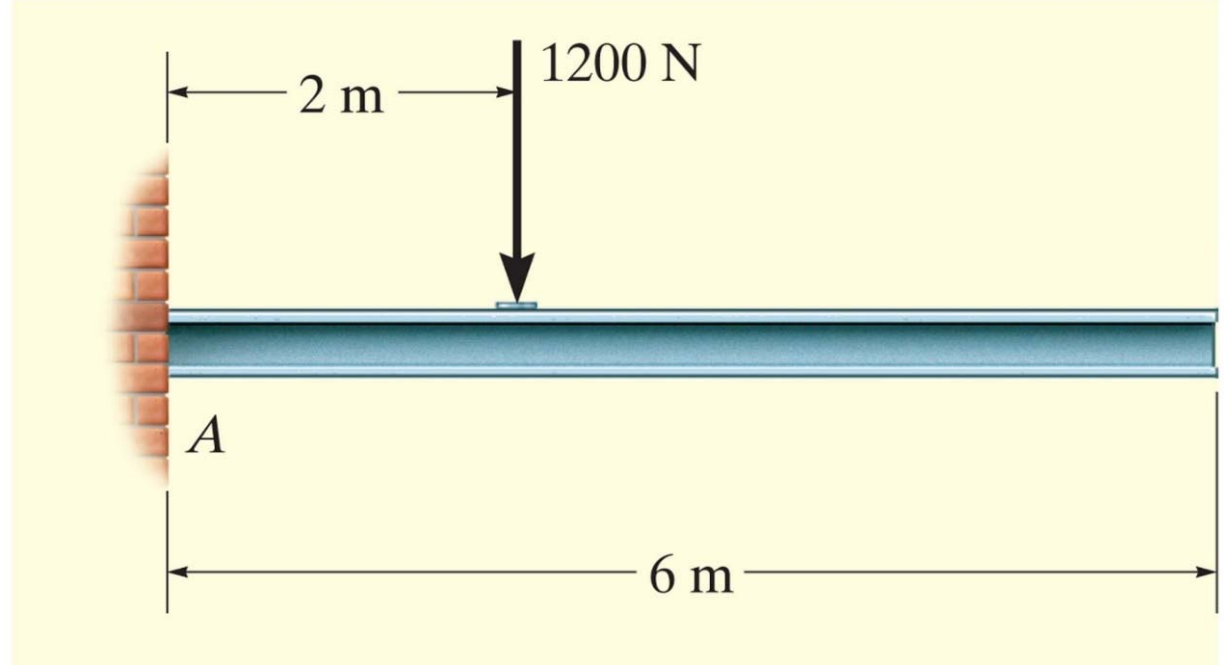

The operator applies a vertical force to the pedal so that the spring is stretched 1.5 in. and the force in the short link at B is 20 lb. Draw the FBD of the pedal

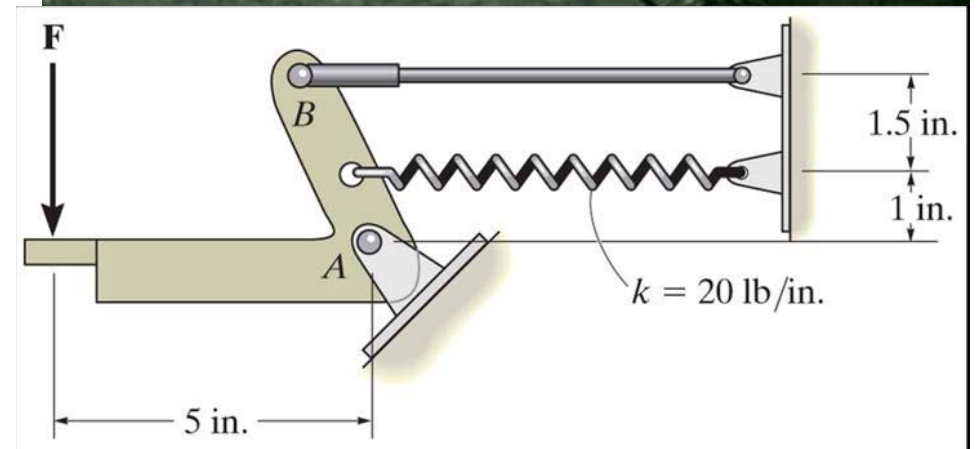

Identify support reaction types. Draw the FBD of body AB with forces in Cartesian coordinates.

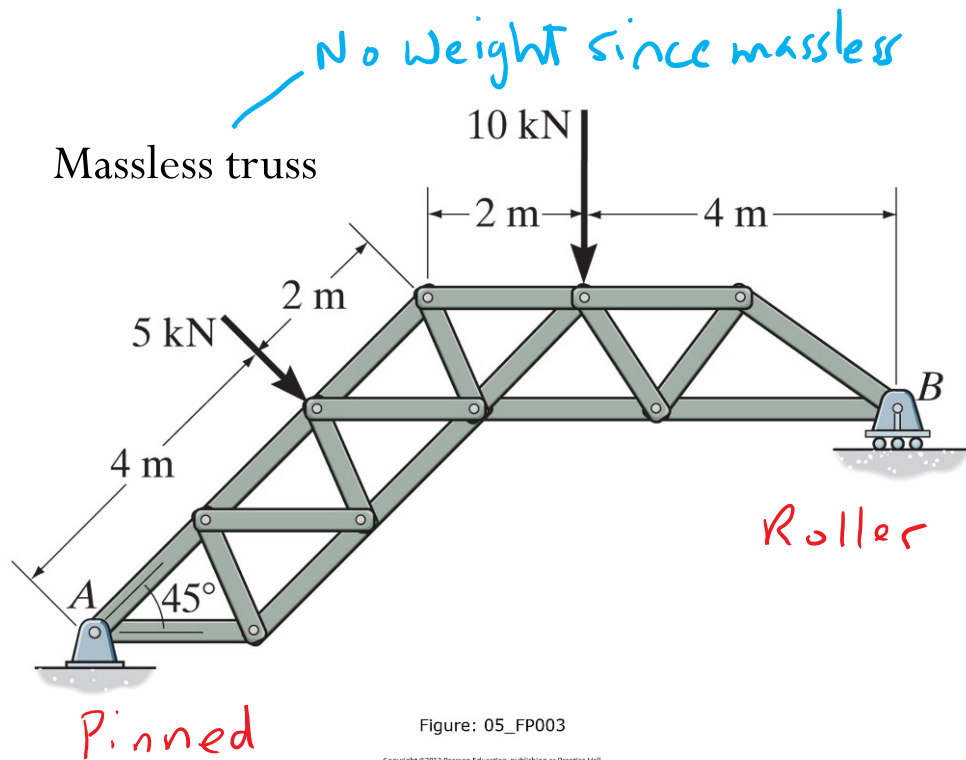
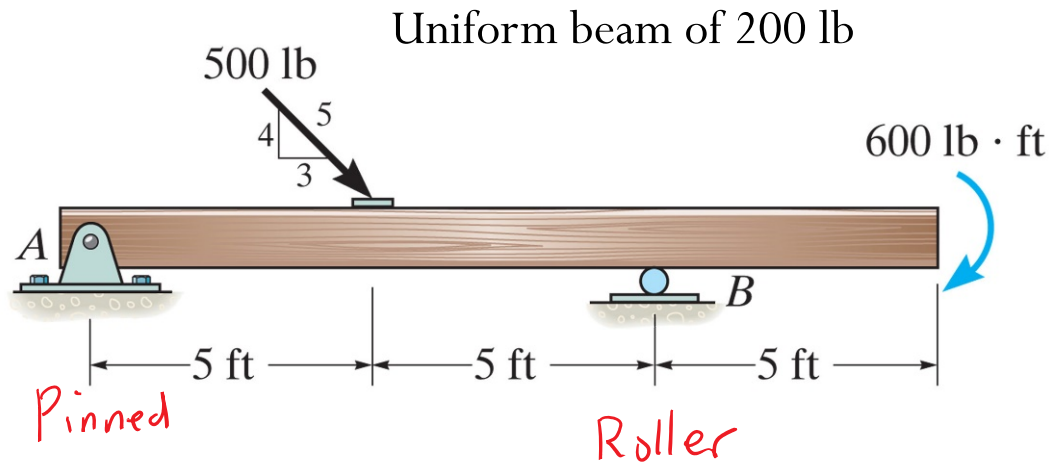
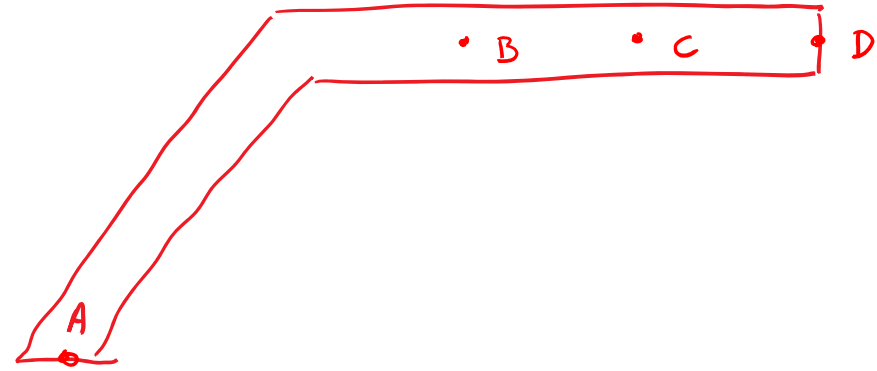
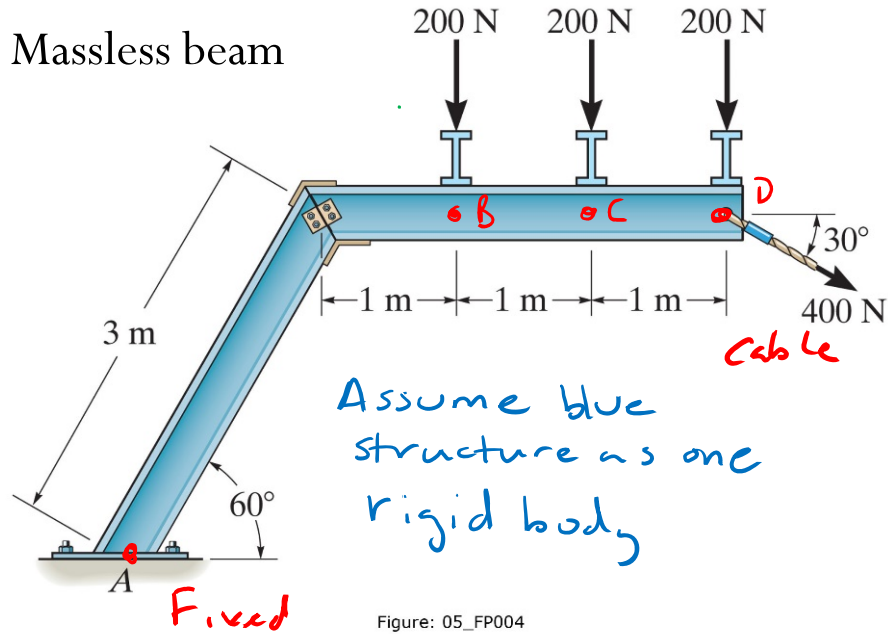
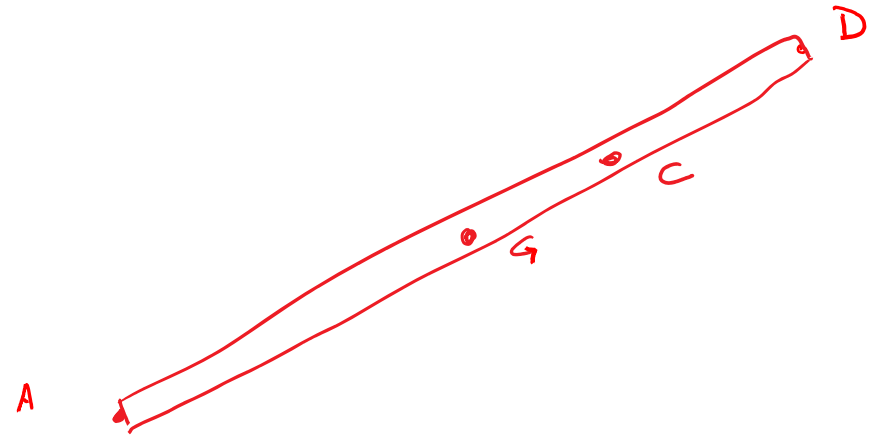
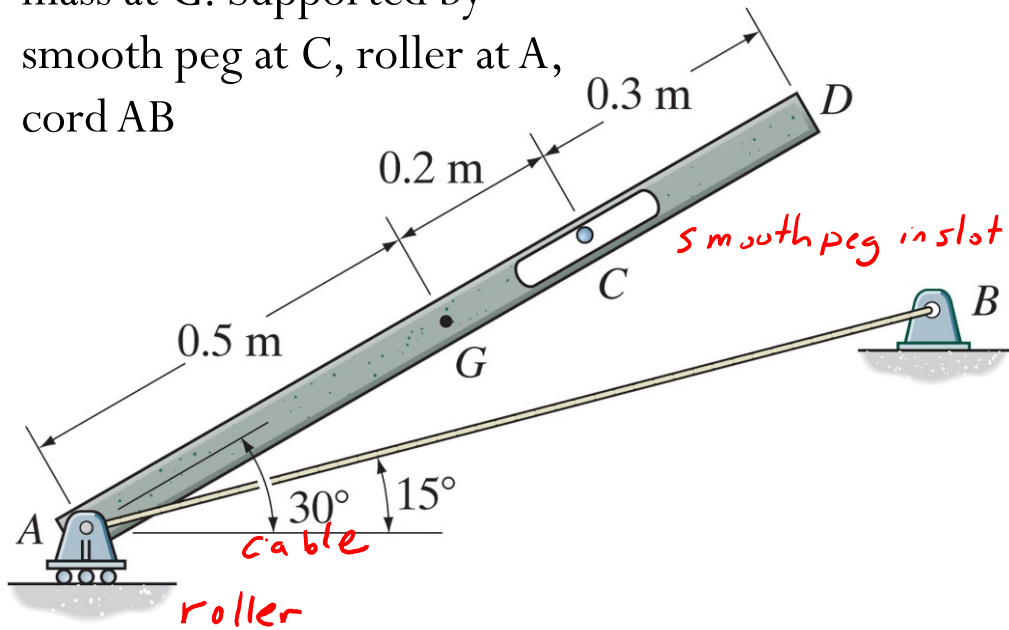

Figure: 05_FP003

Identify support reaction types. Draw the FBD of rigid body with forces in Cartesian coordinates.



25 kg bar with center of mass at G. Supported by smooth peg at C, roller at A, cord AB



Two-force members

As the name implies, two-force members have forces applied at only two points.

If we apply the equations of equilibrium to such members, we can quickly determine that **the resultant forces at A and B must be equal in magnitude and act in the opposite directions along the line joining points A and B.**

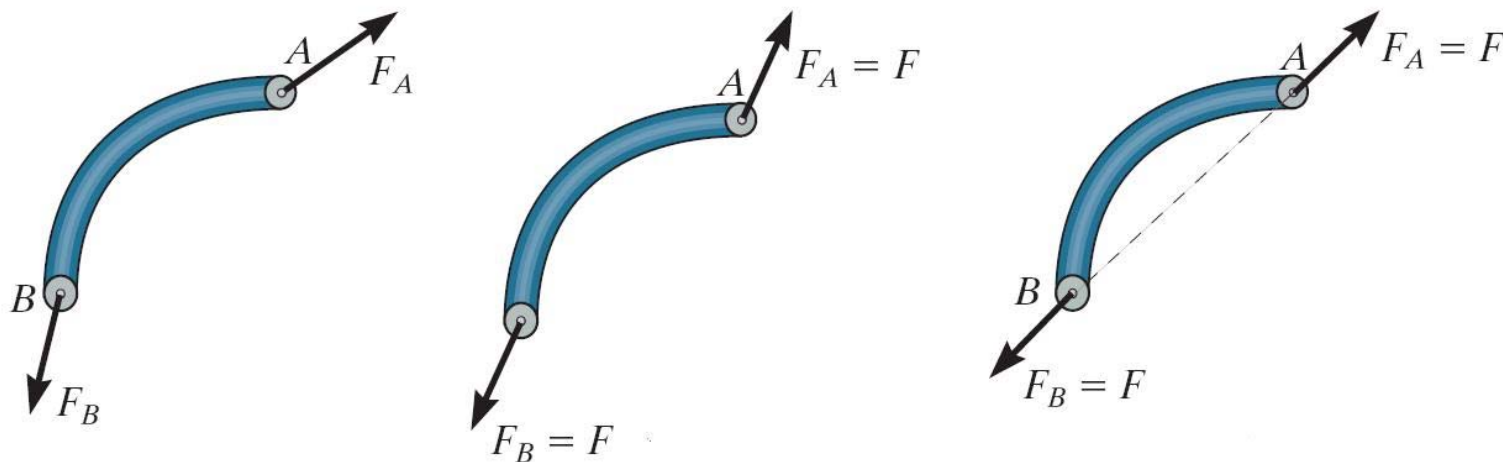

Two-force member: the two forces at ends are equal, opposite, collinear

Examples of two-force members



In the cases above, members AB can be considered as two-force members, provided that their weight is neglected.

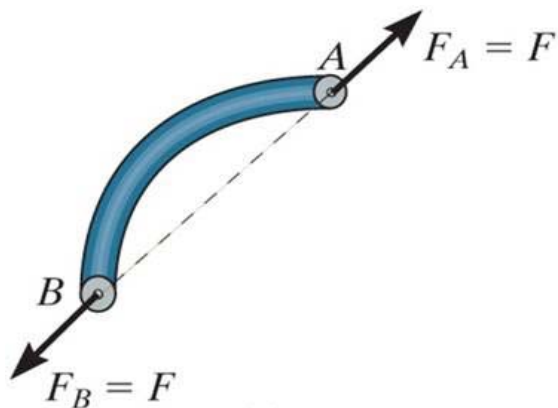

Two-force members **simplify** the equilibrium analysis of some rigid bodies since the **directions of the resultant forces at A and B are thus known** (along the line joining points A and B).

Three-force members

As the name implies, three-force members have forces applied at only three points.

Moment equilibrium can be satisfied only if the three forces are concurrent or parallel force system

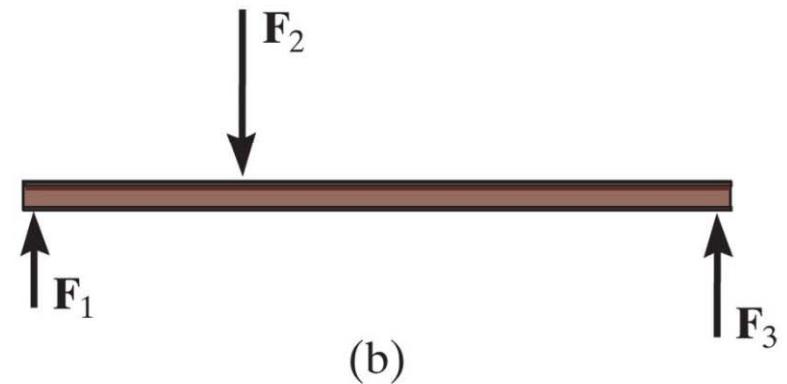
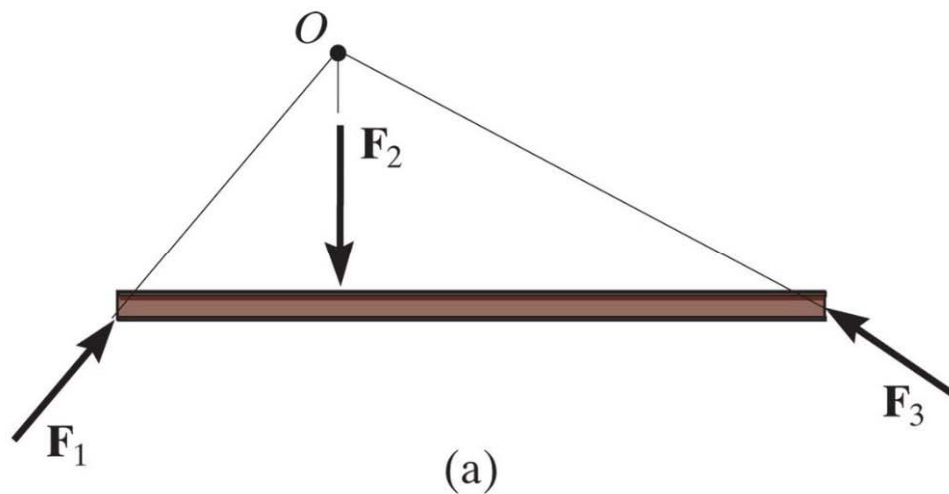

Three-force member: a force system where the three forces
(a) meet at the same point (point O), or
(b) are parallel

Two-force and three-force members

One can use these concepts to quickly identify the direction of an unknown force.

Two-force member:
the two forces at ends are equal, opposite, collinear

Three-force member: a force system where the three forces

1. meet at the same point (point O), or
2. are parallel

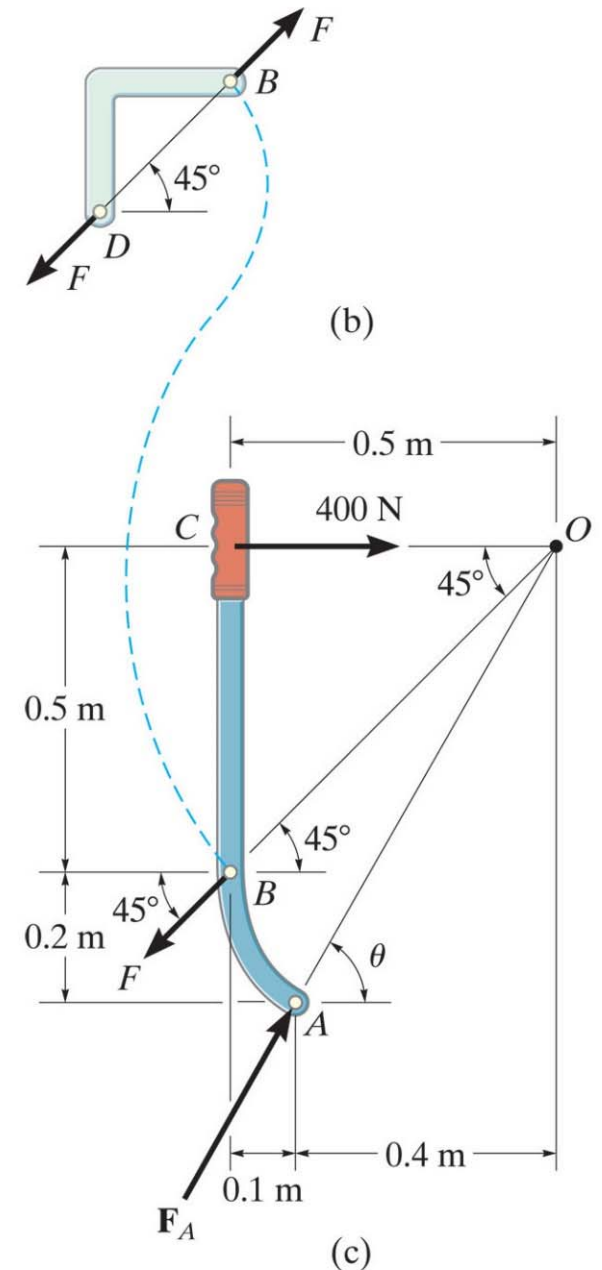
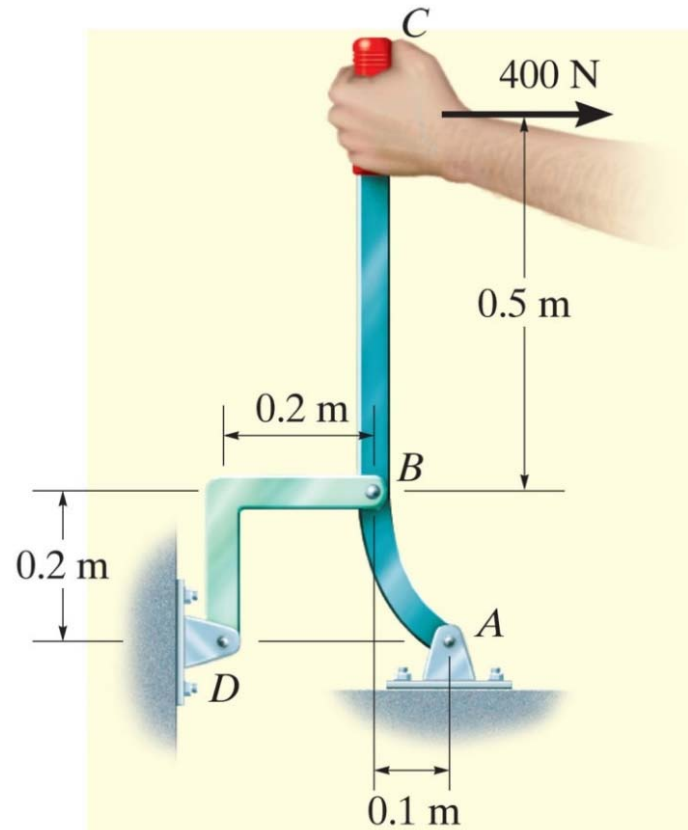

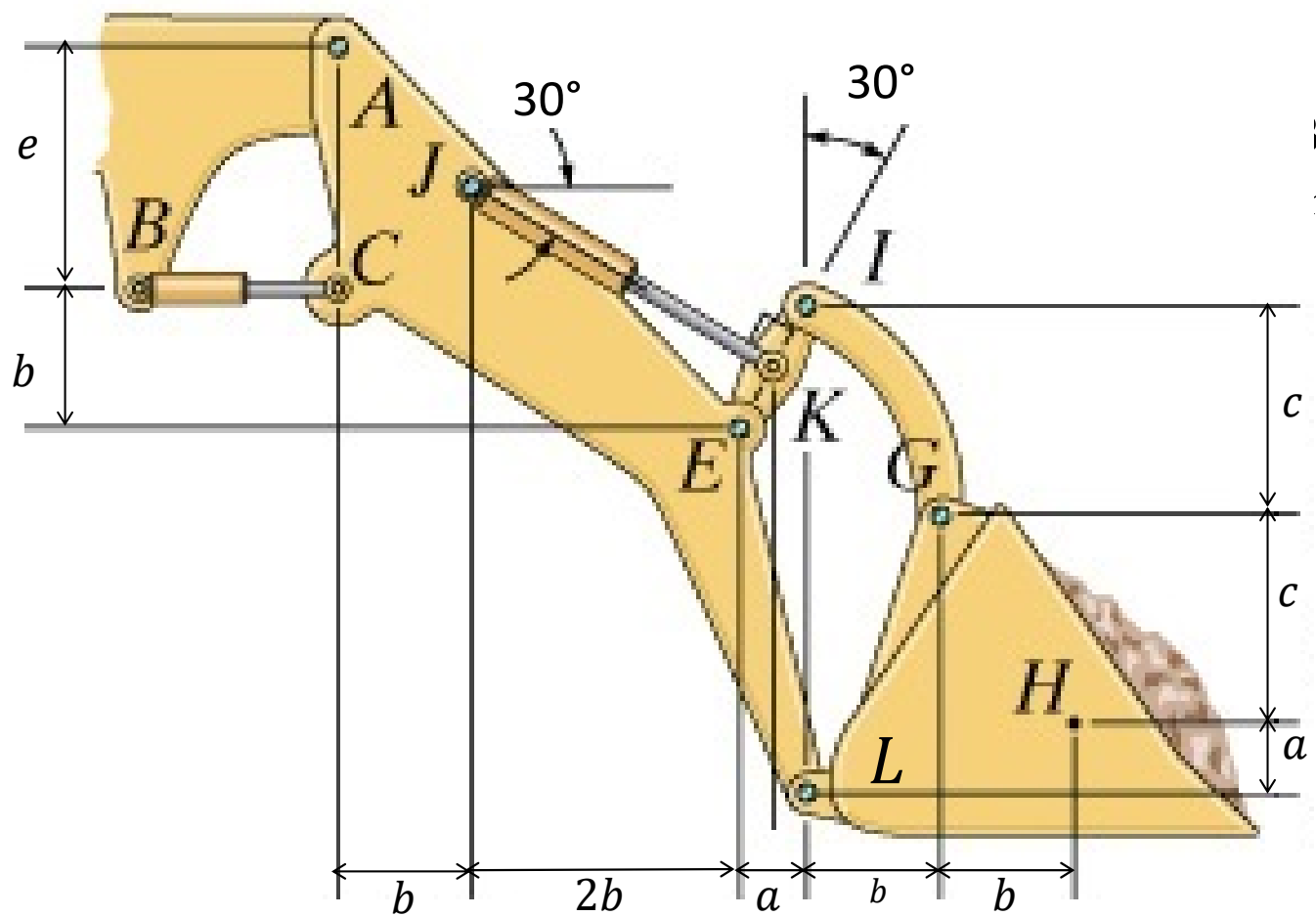

for each two or three force
(C, JK, IE, I, G, Bucket). Ignore
a link. Include dirt weight in bucket.

Line of action of an unknown force can be determined from 2- or 3-force members

2-force member:

The 2 forces at ends are equal, opposite, collinear

3-force member: force system where the 3 forces

1. meet at the same point, or
2. are parallel

Directions of arrows of unknown forces/moments are arbitrary on FBD. Actual direction will be determined after solving for unknown values

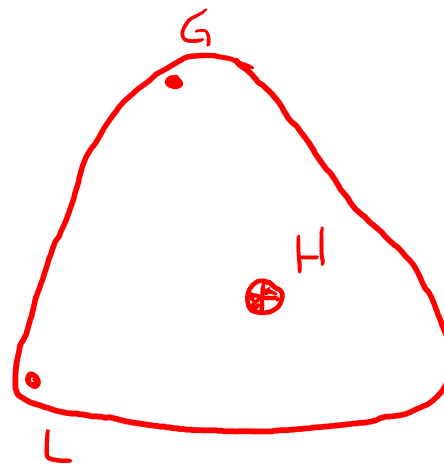
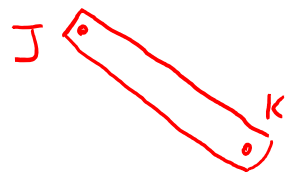
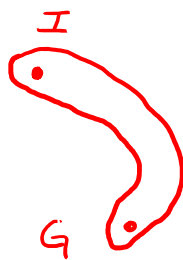
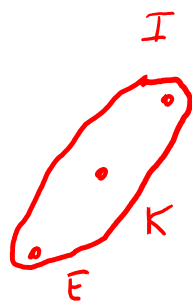

Constraints

To ensure equilibrium of a rigid body, it is not only necessary to satisfy equations of equilibrium, but the body must also be properly constrained by its supports

- **Redundant constraints:** the body has more supports than necessary to hold it in equilibrium; the problem is **STATICALLY INDETERMINATE** and cannot be solved with statics alone. **Too many unknowns, not enough equations**

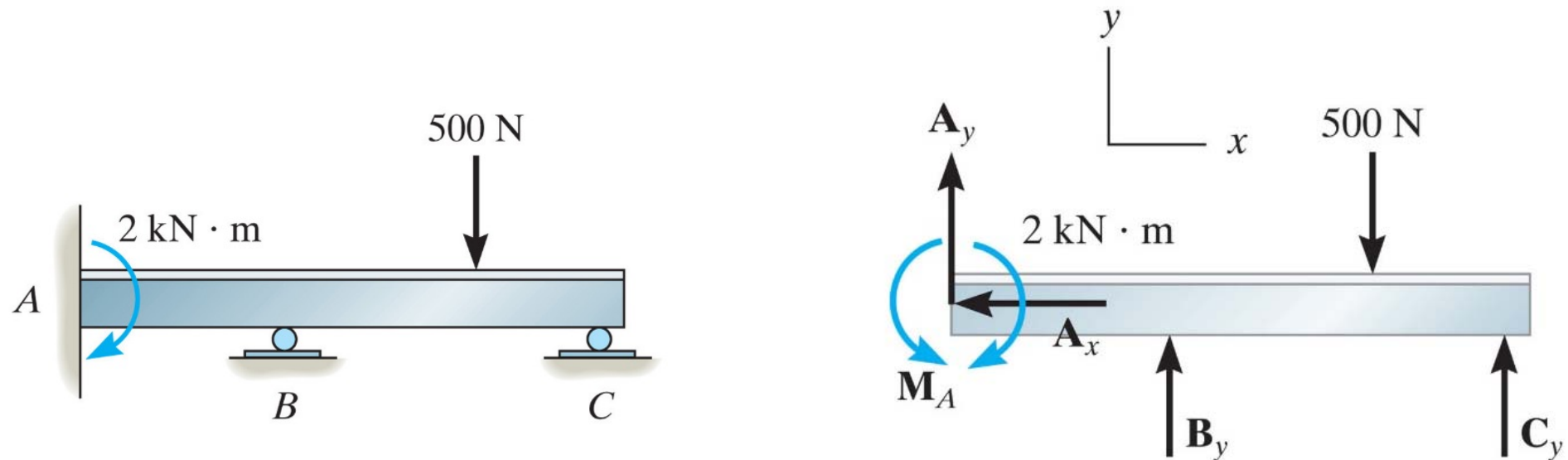

Constraints

- **Improper constraints:** In some cases, there may be as many unknown reactions as there are equations of equilibrium (statically determinate). However, if the supports are not properly constrained, the body may become unstable for some loading cases.
 - BAD: Reactive forces are concurrent at same point (point A) or line of action

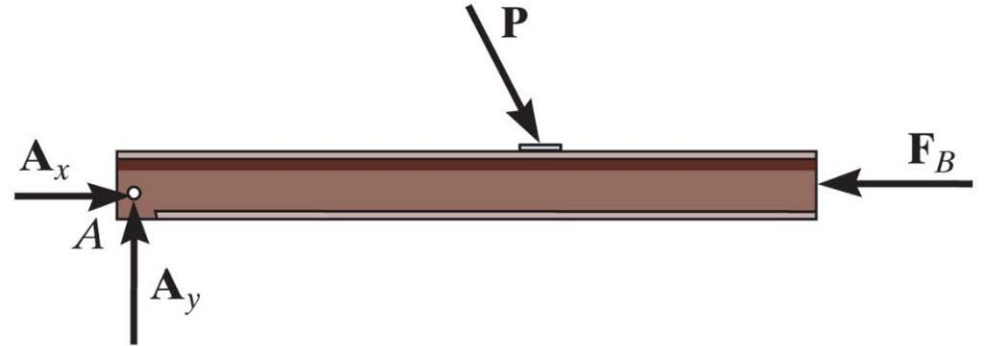
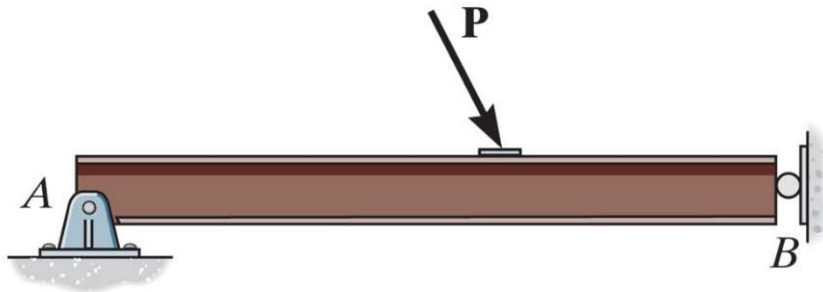

- BAD: Reactive forces are parallel

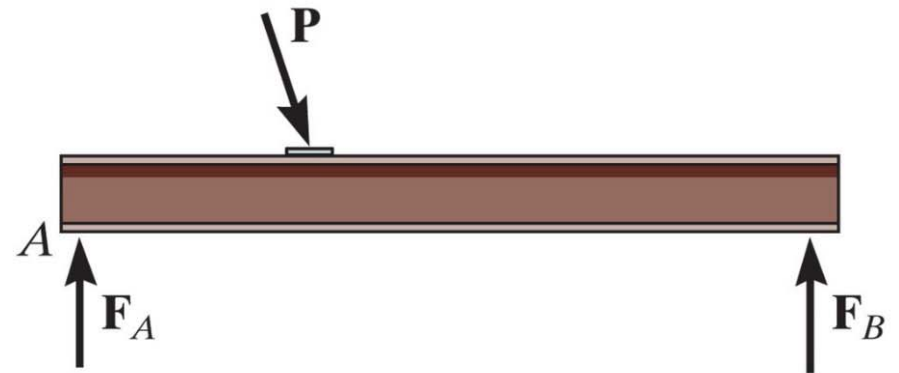
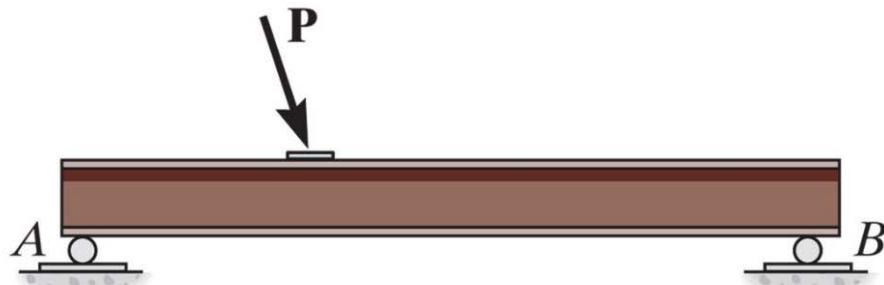

Stable body: lines of action of reactive forces do not intersect at common axis, and are not parallel